

alpha Value Line

PLANETARY GEARBOXES NP / NPL / NPS / NPT / NPR

The strength of the planetary gearboxes of the alpha Value Line lies in the combination of economy and variety of output variants. Additionally, the gearboxes are suitable for very diverse applications – thanks to the range of ratios and the optimal positioning accuracy.

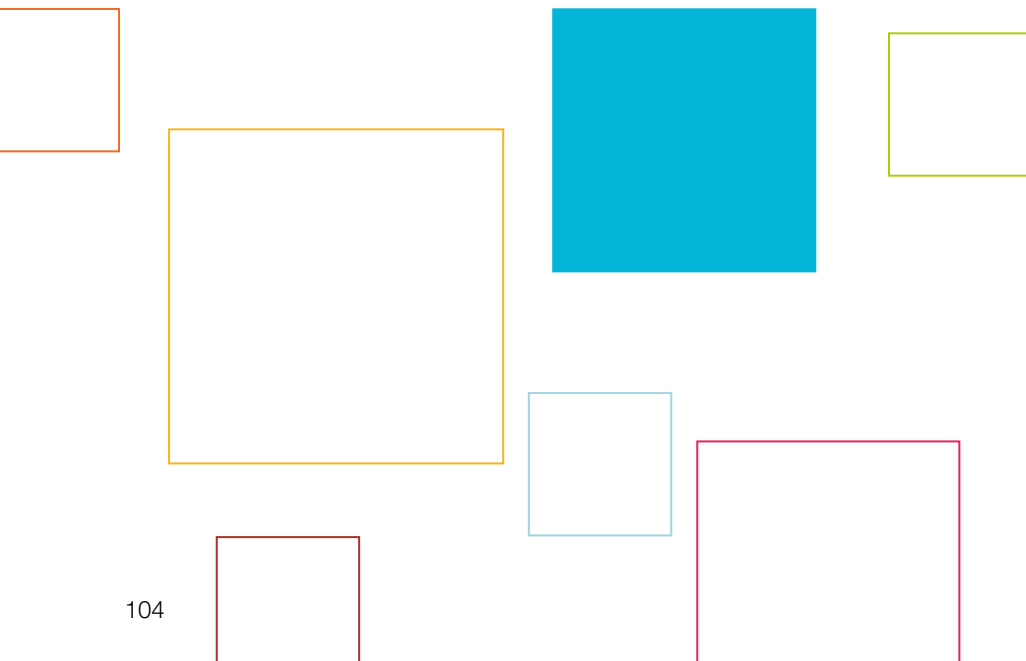

NP



NPL



NPS



NPR



NPT

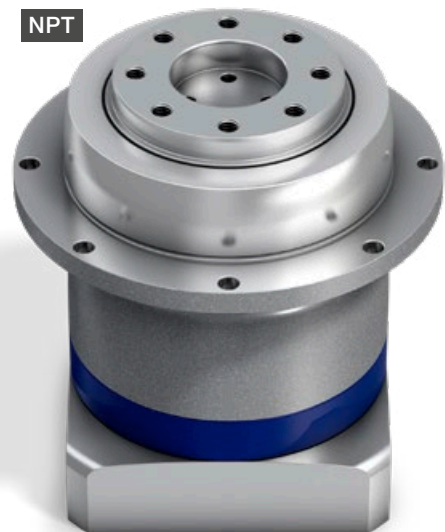

alpha Value Line in action

INDIVIDUAL TALENTS – for trend-setting research

The planetary gearboxes of the alpha Value Line are suitable for universal application and offer the best economical solution for almost every requirement – on each axis and for all industries.

But the NP servo gearbox is also used outside the typical industrial environment: For research purposes, the planetary gearboxes are used in installations for the simulation of tides or tsunamis as well as for coastline and port basin optimization. With the wave simulators, shipyards or research centers can simulate and investigate the behavior of ships at sea or in a port, in ordinary but also in extreme situations.

The low-backlash NP planetary gearboxes of the alpha Value Line drive axes optimally in installations of multi-servo axes in wave tanks worldwide – for example in Great Britain, the USA, China and Italy.

Each wave simulator has a certain number of paddles for generating very special wave types and frequencies. Depending on the size of the simulator and the type of wave to be simulated – deep and shallow water, sea, current and storm conditions or river mouths – a belt drive, ball screw or rack and pinion drive are used. The size of the individual paddles can vary from a few centimeters to several meters.

Technical support, quality and flexibility were the decisive factors for the decision to cooperate with WITTENSTEIN in the simulation system. The NP gearboxes of the alpha Value Line offer the customer the ideal mix of precision, dynamic performance and price.





NP / NPL / NPS / NPT / NPR

– Individual Talents



The planetary gearboxes of the NP series are universally applicable and offer the best economical solution for almost every requirement, in each axis in every sector. The various drives and output interfaces are offered as a compatible extension to the existing portfolio of WITTENSTEIN alpha – for maximum flexibility in design, assembly, and use.

PRODUCT HIGHLIGHTS

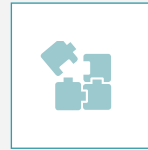

Unique modularity in this segment

With five series including five different output interfaces, the NP series offers maximum flexibility. From a simple machine connection using a B5 or B14 output flange to a flange connection or adjustment via slotted holes – the suitable solution for your machine requirements.



High economy

The gearboxes of the alpha Value Line are very economical to purchase, unbeatably efficient in operation, and maintenance free over their entire service life.

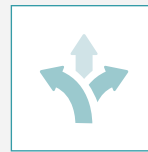

High flexibility

Modular configuration of the interfaces to the motor and to the application. The gearboxes are available with different clamping hub diameters, drive stages, design and mounting options.



Highest power density

The HIGH TORQUE version provides gearboxes with the highest power density.



Fast sizing

Efficient online sizing within seconds in the SIZING ASSISTANT on the basis of the application data or the motor.



NPS – planetary gearbox with SP* output geometry



NPL – planetary gearbox with reinforced bearings and B14 output geometry

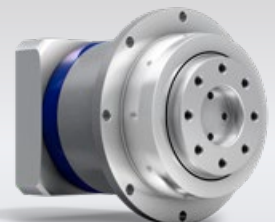

NPT – planetary gearbox with TP* output geometry



More information about the alpha Value Line: simply scan the QR code using your smartphone.

<https://alpha.wittenstein.de/en-en/alpha-value-line/>



A Two-piece clamping hub system of the high-end segment

- Labeled with the tightening torques for secure, fast motor mounting
- Guarantees best synchronization properties

B Various output shapes

- Five variants of the NP series available: including with B5 flange mounting, output flange, etc.
- Higher external forces possible with NPL, NPS, and NPR

C High ratio variation

- Large number of ratios ($i=3$ to $i=100$)
- Available in the common binary ratios

D Differentiated power density

- The HIGH TORQUE version permits an even higher torque density for sizes 015 – 035



SIZING ASSISTANT
YOUR GEARBOX WITHIN SECONDS

NP 005 MF 1-stage

			1-stage						
Ratio	i		4	5	7	8	10		
Max. torque ^{a) b) e)}	T_{2a}	Nm	18	22	22	21	21		
		in.lb	159	195	195	186	186		
Max. acceleration torque ^{e)} (max. 1000 cycles per hour)	T_{2B}	Nm	11	14	14	13	13		
		in.lb	97	124	124	115	115		
Emergency stop torque ^{a) b) e)} (permitted 1000 times during the service life of the gearbox)	T_{2Not}	Nm	26	26	26	26	26		
		in.lb	230	230	230	230	230		
Permitted average input speed ^{d)} (at T_{2a} and 20 °C ambient temperature)	n_{1N}	rpm	3800	4000	4300	4400	4600		
Max. input speed	n_{1Max}	rpm	10000	10000	10000	10000	10000		
Mean no load running torque ^{b)} (at $n_1=3000$ rpm and 20 °C gearbox temperature)	T_{012}	Nm	0.1	0.09	0.08	0.08	0.08		
		in.lb	0.89	0.8	0.71	0.71	0.71		
Max. backlash	j_1	arcmin	≤ 10						
Torsional rigidity ^{b)}	C_{121}	Nm/arcmin	1.2	1.2	1.2	0.85	0.85		
		in.lb/arcmin	11	11	11	7.5	7.5		
Max. axial force ^{c)}	F_{2AMax}	N	700						
		lb _f	158						
Max. lateral force ^{c)}	F_{2QMMax}	N	800						
		lb _f	180						
Max. tilting moment	M_{2KMMax}	Nm	23						
		in.lb	204						
Efficiency at full load	η	%	97						
Service life	L_n	h	> 20000						
Weight (incl. standard adapter plate)	m	kg	0.7						
		lb _m	1.5						
Operating noise (at reference ratio and reference speed – ratio-specific values available in cymex®)	L_{PA}	dB(A)	≤ 58						
Max. permitted housing temperature		°C	+90						
		°F	+194						
Ambient temperature		°C	-15 to +40						
		°F	+5 to +104						
Lubrication			Lubricated for life						
Direction of rotation			In- and output same direction						
Protection class			IP 64						
Elastomer coupling (recommended product type – validate sizing with cymex®)			ELC-0005BA012.000-X						
Bore diameter of coupling on the application side		mm	X = 004.000 - 012.700						
Mass moment of inertia (relates to the drive) Clamping hub diameter [mm]	Z	8	J_1	kgcm ²	0.03	0.03	0.03	0.02	0.02
				10 ⁻³ in.lb.s ²	0.03	0.03	0.03	0.02	0.02
	A	9	J_1	kgcm ²	0.03	0.03	0.03	0.03	0.02
				10 ⁻³ in.lb.s ²	0.03	0.03	0.03	0.03	0.02
	B	11	J_1	kgcm ²	0.05	0.05	0.04	0.04	0.04
				10 ⁻³ in.lb.s ²	0.04	0.04	0.04	0.04	0.04
C	14	J_1	kgcm ²	0.14	0.13	0.13	0.13	0.13	
			10 ⁻³ in.lb.s ²	0.12	0.12	0.12	0.12	0.12	

Please use our sizing software cymex® for a detailed sizing – www.wittenstein-cymex.com

^{a)} Valid for torque transmission only

^{b)} Valid for standard clamping hub diameter

^{c)} Refers to center of the output shaft or flange

^{d)} Please reduce input speed at higher ambient temperatures

^{e)} Valid for: Smooth shaft

1-stage

Motor shaft diameter [mm]

up to 11⁴⁾ (B)⁵⁾
clamping hub diameter

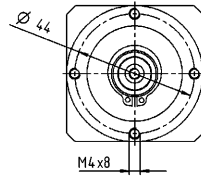

up to 14⁴⁾ (C)
clamping hub diameter

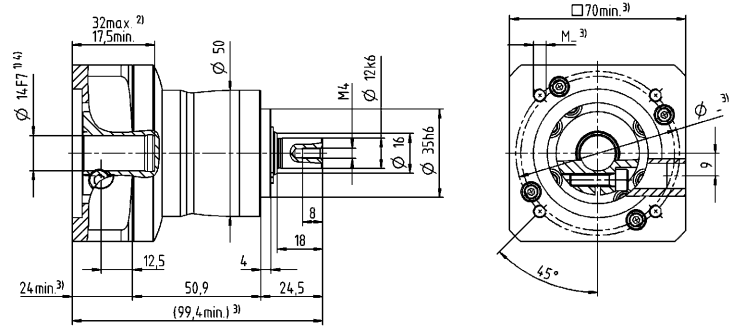
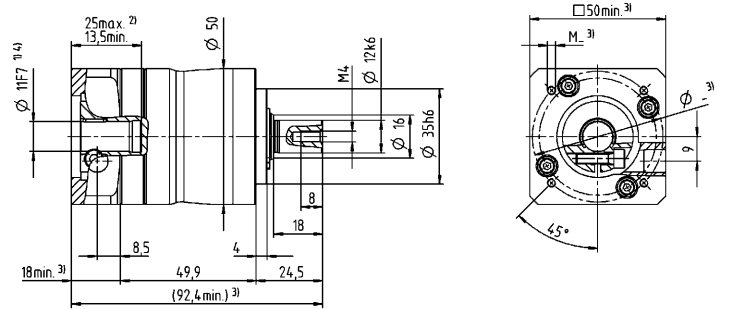
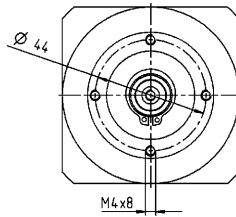

Other output variants

Shaft with key

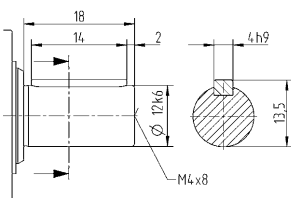

Non-tolerated dimensions are nominal dimensions

¹⁾ Check motor shaft fit

²⁾ Min. / Max. permissible motor shaft length

Longer motor shafts are possible, please contact alpha

³⁾ The dimensions depend on the motor

⁴⁾ Smaller motor shaft diameter is compensated

by a bushing with a minimum thickness of 1 mm

⁵⁾ Standard clamping hub diameter

NP 005 MF 2-stage

			2-stage										
Ratio	i		16	20	25	28	35	40	50	64	70	100	
Max. torque ^{a) b) e)}	T_{2a}	Nm	18	18	22	18	22	18	22	21	22	21	
		in.lb	159	159	195	159	195	159	195	186	195	186	
Max. acceleration torque ^{e)} (max. 1000 cycles per hour)	T_{2B}	Nm	11	11	14	11	14	11	14	13	14	13	
		in.lb	97	97	124	97	124	97	124	115	124	115	
Emergency stop torque ^{a) b) e)} (permitted 1000 times during the service life of the gearbox)	T_{2Not}	Nm	26	26	26	26	26	26	26	26	26	26	
		in.lb	230	230	230	230	230	230	230	230	230	230	
Permitted average input speed ^{d)} (at T_{2N} and 20 °C ambient temperature)	n_{1N}	rpm	4000	4000	4000	4300	4300	4600	4600	4400	4600	4600	
Max. input speed	n_{1Max}	rpm	10000	10000	10000	10000	10000	10000	10000	10000	10000	10000	
Mean no load running torque ^{b)} (at $n_1=3000$ rpm and 20 °C gearbox temperature)	T_{012}	Nm	0.11	0.1	0.1	0.09	0.09	0.08	0.08	0.08	0.08	0.08	
		in.lb	0.97	0.89	0.89	0.8	0.8	0.71	0.71	0.71	0.71	0.71	
Max. backlash	j_l	arcmin	≤ 13										
Torsional rigidity ^{b)}	C_{121}	Nm/arcmin	1.2	1.2	1.2	1.2	1.2	1.2	1.2	0.85	1.2	0.85	
		in.lb/arcmin	11	11	11	11	11	11	11	7.5	11	7.5	
Max. axial force ^{c)}	F_{2AMax}	N	700										
		lb _f	158										
Max. lateral force ^{c)}	F_{2QMMax}	N	800										
		lb _f	180										
Max. tilting moment	M_{2KMMax}	Nm	23										
		in.lb	204										
Efficiency at full load	η	%	95										
Service life	L_n	h	> 20000										
Weight (incl. standard adapter plate)	m	kg	0.9										
		lb _m	2										
Operating noise (at reference ratio and reference speed – ratio-specific values available in cymex®)	L_{PA}	dB(A)	≤ 58										
Max. permitted housing temperature		°C	+90										
		°F	+194										
Ambient temperature		°C	-15 to +40										
		°F	+5 to +104										
Lubrication			Lubricated for life										
Direction of rotation			In- and output same direction										
Protection class			IP 64										
Elastomer coupling (recommended product type – validate sizing with cymex®)			ELC-0005BA012.000-X										
Bore diameter of coupling on the application side		mm	X = 004.000 - 012.700										
Mass moment of inertia (relates to the drive) Clamping hub diameter [mm]	Z	8	J_1	kgcm ²	0.03	0.03	0.03	0.03	0.03	0.02	0.02	0.02	0.02
				10 ⁻³ in.lb.s ²	0.03	0.03	0.03	0.03	0.03	0.02	0.02	0.02	0.02
	A	9	J_1	kgcm ²	0.03	0.03	0.02	0.03	0.03	0.02	0.02	0.02	0.02
				10 ⁻³ in.lb.s ²	0.03	0.03	0.02	0.03	0.03	0.02	0.02	0.02	0.02
	B	11	J_1	kgcm ²	0.05	0.05	0.04	0.05	0.04	0.04	0.04	0.04	0.04
				10 ⁻³ in.lb.s ²	0.04	0.04	0.04	0.04	0.04	0.04	0.04	0.04	0.04
	C	14	J_1	kgcm ²	0.13	0.13	0.13	0.13	0.13	0.13	0.13	0.13	0.13
				10 ⁻³ in.lb.s ²	0.12	0.12	0.12	0.12	0.12	0.12	0.12	0.12	0.12

Please use our sizing software cymex® for a detailed sizing – www.wittenstein-cymex.com

^{a)} Valid for torque transmission only

^{b)} Valid for standard clamping hub diameter

^{c)} Refers to center of the output shaft or flange

^{d)} Please reduce input speed at higher ambient temperatures

^{e)} Valid for: Smooth shaft

2-stage

up to 11⁴⁾ (B)⁵⁾
clamping hub
diameter

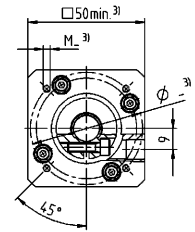
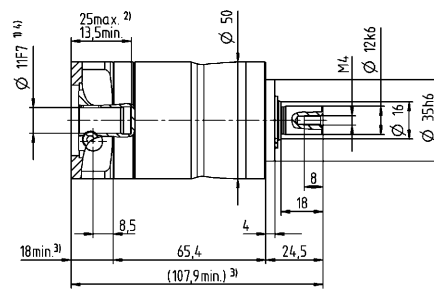
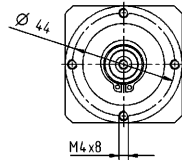

Motor shaft diameter [mm]

up to 14⁴⁾ (C)
clamping hub
diameter

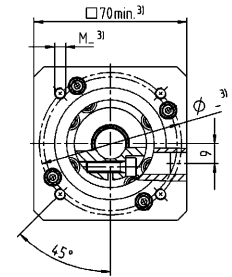
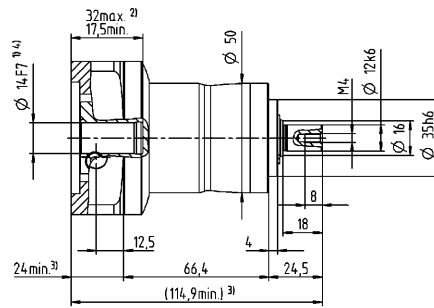
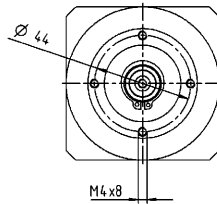

Planetary Gearboxes
Value Line

Other output variants

Shaft with key

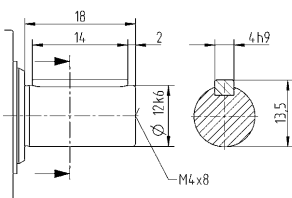

Non-tolerated dimensions are nominal dimensions

¹⁾ Check motor shaft fit

²⁾ Min. / Max. permissible motor shaft length

Longer motor shafts are possible, please contact alpha

³⁾ The dimensions depend on the motor

⁴⁾ Smaller motor shaft diameter is compensated

by a bushing with a minimum thickness of 1 mm

⁵⁾ Standard clamping hub diameter

NP 015 MF 1-stage

			1-stage							
Ratio	i		3	4	5	7	8	10		
Max. torque ^{a) b) e)}	T_{2a}	Nm	51	56	64	64	56	56		
		in.lb	451	496	566	566	496	496		
Max. acceleration torque ^{e)} (max. 1000 cycles per hour)	T_{2B}	Nm	32	35	40	40	35	35		
		in.lb	283	310	354	354	310	310		
Emergency stop torque ^{a) b) e)} (permitted 1000 times during the service life of the gearbox)	T_{2Not}	Nm	80	80	80	80	80	80		
		in.lb	708	708	708	708	708	708		
Permitted average input speed ^{d)} (at T_{2a} and 20 °C ambient temperature)	n_{1N}	rpm	3300	3500	3700	4000	4100	4300		
Max. input speed	n_{1Max}	rpm	8000	8000	8000	8000	8000	8000		
Mean no load running torque ^{b)} (at $n_1=3000$ rpm and 20 °C gearbox temperature)	T_{012}	Nm	0.24	0.2	0.17	0.14	0.13	0.12		
		in.lb	2.1	1.8	1.5	1.2	1.2	1.1		
Max. backlash	j_l	arcmin	≤ 8							
Torsional rigidity ^{b)}	C_{121}	Nm/arcmin	3.3	3.3	3.3	3.3	2.8	2.8		
		in.lb/arcmin	29	29	29	29	25	25		
Max. axial force ^{c)}	F_{2AMax}	N	1550							
		lb _f	349							
Max. lateral force ^{c)}	F_{2QMMax}	N	1700							
		lb _f	383							
Max. tilting moment	M_{2KMMax}	Nm	72							
		in.lb	637							
Efficiency at full load	η	%	97							
Service life	L_n	h	> 20000							
Weight (incl. standard adapter plate)	m	kg	1.9							
		lb _m	4.2							
Operating noise (at reference ratio and reference speed – ratio-specific values available in cymex [®])	L_{PA}	dB(A)	≤ 59							
Max. permitted housing temperature		°C	+90							
		°F	+194							
Ambient temperature		°C	-15 to +40							
		°F	+5 to +104							
Lubrication			Lubricated for life							
Direction of rotation			In- and output same direction							
Protection class			IP 64							
Elastomer coupling (recommended product type – validate sizing with cymex [®])			ELC-0060BA016.000-X							
Bore diameter of coupling on the application side		mm	X = 012.000 - 032.000							
Mass moment of inertia (relates to the drive) Clamping hub diameter [mm]	A	9	J_1	kgcm ²	0.22	0.18	0.16	0.14	0.14	0.13
				10 ⁻³ in.lb.s ²	0.19	0.16	0.14	0.12	0.12	0.12
	B	11	J_1	kgcm ²	0.24	0.19	0.18	0.16	0.15	0.15
				10 ⁻³ in.lb.s ²	0.21	0.17	0.16	0.14	0.13	0.13
	C	14	J_1	kgcm ²	0.32	0.27	0.25	0.23	0.23	0.22
				10 ⁻³ in.lb.s ²	0.28	0.24	0.22	0.2	0.2	0.19
	D	16	J_1	kgcm ²	0.45	0.4	0.38	0.36	0.36	0.35
				10 ⁻³ in.lb.s ²	0.4	0.35	0.34	0.32	0.32	0.31
	E	19	J_1	kgcm ²	0.53	0.48	0.46	0.44	0.44	0.43
				10 ⁻³ in.lb.s ²	0.47	0.42	0.41	0.39	0.39	0.38

Please use our sizing software cymex[®] for a detailed sizing – www.wittenstein-cymex.com

^{a)} Valid for torque transmission only

^{b)} Valid for standard clamping hub diameter

^{c)} Refers to center of the output shaft or flange

^{d)} Please reduce input speed at higher ambient temperatures

^{e)} Valid for: Smooth shaft

1-stage

Motor shaft diameter [mm]

up to 14⁴⁾ (C)⁵⁾
clamping hub diameter

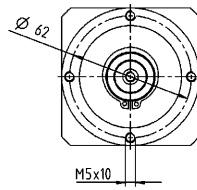

up to 19⁴⁾ (E)
clamping hub diameter

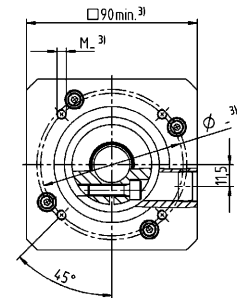
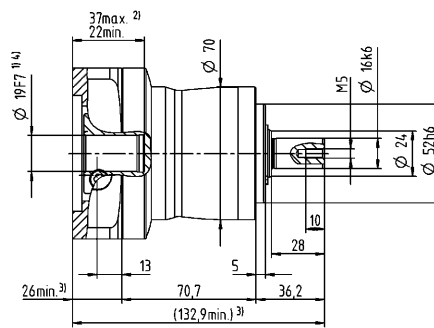
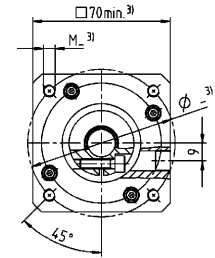
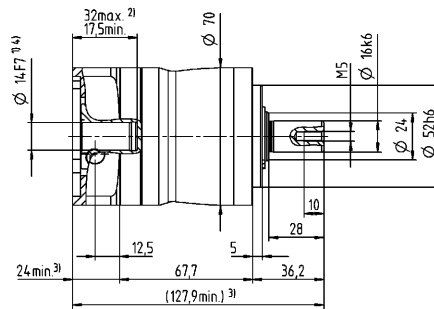
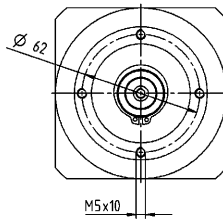

Planetary Gearboxes
Value Line

Other output variants

Shaft with key

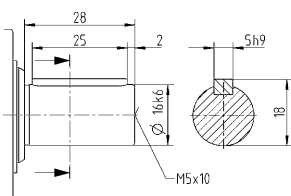

Non-tolerated dimensions are nominal dimensions

¹⁾ Check motor shaft fit

²⁾ Min. / Max. permissible motor shaft length

Longer motor shafts are possible, please contact alpha

³⁾ The dimensions depend on the motor

⁴⁾ Smaller motor shaft diameter is compensated

by a bushing with a minimum thickness of 1 mm

⁵⁾ Standard clamping hub diameter

NP 015 MF 2-stage

			2-stage														
Ratio	i		12	15	16	20	25	28	30	32	35	40	50	64	70	100	
Max. torque ^{a) b) e)}	T_{2a}	Nm	51	51	56	56	64	56	51	56	64	56	64	56	64	56	
		in.lb	451	451	496	496	566	496	451	496	566	496	566	496	566	496	566
Max. acceleration torque ^{e)} (max. 1000 cycles per hour)	T_{2B}	Nm	32	32	35	35	40	35	32	35	40	35	40	35	40	35	
		in.lb	283	283	310	310	354	310	283	310	354	310	354	310	354	310	354
Emergency stop torque ^{a) b) e)} (permitted 1000 times during the service life of the gearbox)	T_{2Not}	Nm	80	80	80	80	80	80	80	80	80	80	80	80	80	80	
		in.lb	708	708	708	708	708	708	708	708	708	708	708	708	708	708	708
Permitted average input speed ^{d)} (at T_{2a} and 20 °C ambient temperature)	n_{1N}	rpm	3800	4000	3800	4000	4000	4300	4600	4400	4300	4600	4600	4400	4600	4600	
Max. input speed	n_{1Max}	rpm	10000	10000	10000	10000	10000	10000	10000	10000	10000	10000	10000	10000	10000	10000	
Mean no load running torque ^{b)} (at $n_1=3000$ rpm and 20 °C gearbox temperature)	T_{012}	Nm	0.13	0.11	0.12	0.11	0.1	0.09	0.09	0.09	0.09	0.08	0.08	0.08	0.08	0.08	
		in.lb	1.2	0.97	1.1	0.97	0.89	0.8	0.8	0.8	0.8	0.71	0.71	0.71	0.71	0.71	
Max. backlash	j_l	arcmin	≤ 10														
Torsional rigidity ^{b)}	C_{i21}	Nm/arcmin	3.3	3.3	3.3	3.3	3.3	3.3	4	3.3	3.3	3.3	3.3	2.8	3.3	2.8	
		in.lb/arcmin	29	29	29	29	29	29	35	29	29	29	29	25	29	25	
Max. axial force ^{c)}	F_{2AMax}	N	1550														
		lb _f	349														
Max. lateral force ^{c)}	F_{2QMMax}	N	1700														
		lb _f	383														
Max. tilting moment	M_{2KMMax}	Nm	72														
		in.lb	637														
Efficiency at full load	η	%	95														
Service life	L_n	h	> 20000														
Weight (incl. standard adapter plate)	m	kg	1.9														
		lb _m	4.2														
Operating noise (at reference ratio and reference speed – ratio-specific values available in cymex [®])	L_{PA}	dB(A)	≤ 58														
Max. permitted housing temperature		°C	+90														
		°F	+194														
Ambient temperature		°C	-15 to +40														
		°F	+5 to +104														
Lubrication			Lubricated for life														
Direction of rotation			In- and output same direction														
Protection class			IP 64														
Elastomer coupling (recommended product type – validate sizing with cymex [®])			ELC-0060BA016.000-X														
Bore diameter of coupling on the application side		mm	X = 012.000 - 032.000														
Mass moment of inertia (relates to the drive) Clamping hub diameter [mm]	Z	8	J_1	kgcm ²	0.04	0.04	0.03	0.03	0.03	0.03	0.03	0.03	0.03	0.02	0.02	0.02	0.02
				10 ⁻³ in.lb.s ²	0.04	0.04	0.03	0.03	0.03	0.03	0.03	0.03	0.03	0.03	0.02	0.02	0.02
	A	9	J_1	kgcm ²	0.04	0.04	0.03	0.03	0.03	0.03	0.03	0.03	0.03	0.02	0.02	0.02	0.02
				10 ⁻³ in.lb.s ²	0.04	0.04	0.03	0.03	0.03	0.03	0.03	0.03	0.03	0.02	0.02	0.02	0.02
	B	11	J_1	kgcm ²	0.06	0.05	0.05	0.05	0.05	0.05	0.05	0.04	0.05	0.04	0.04	0.04	
				10 ⁻³ in.lb.s ²	0.05	0.04	0.04	0.04	0.04	0.04	0.04	0.04	0.04	0.04	0.04	0.04	0.04
	C	14	J_1	kgcm ²	0.14	0.14	0.14	0.13	0.13	0.13	0.14	0.13	0.13	0.13	0.13	0.13	
				10 ⁻³ in.lb.s ²	0.12	0.12	0.12	0.12	0.12	0.12	0.12	0.12	0.12	0.12	0.12	0.12	0.12

Please use our sizing software cymex[®] for a detailed sizing – www.wittenstein-cymex.com

^{a)} Valid for torque transmission only

^{b)} Valid for standard clamping hub diameter

^{c)} Refers to center of the output shaft or flange

^{d)} Please reduce input speed at higher ambient temperatures

^{e)} Valid for: Smooth shaft

2-stage

Motor shaft diameter [mm]

up to 11⁴⁾ (B)⁵⁾
clamping hub diameter

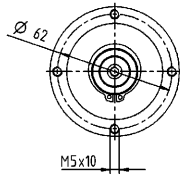

up to 14⁴⁾ (C)
clamping hub diameter

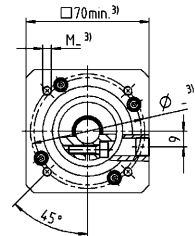
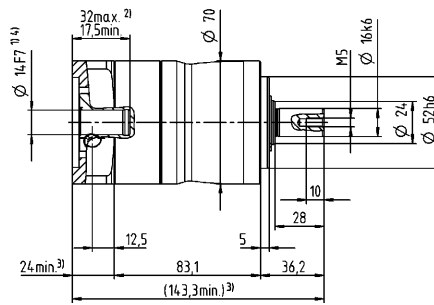
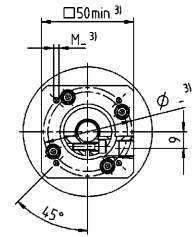
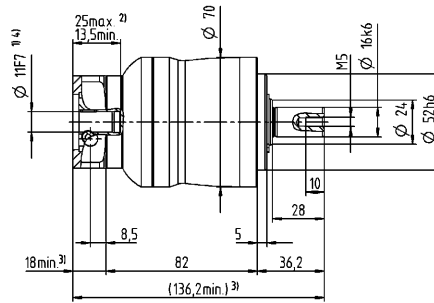
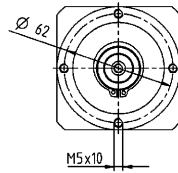

Other output variants

Shaft with key

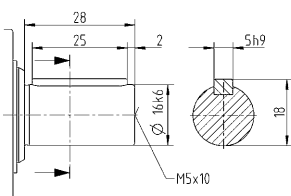

Non-tolerated dimensions are nominal dimensions

¹⁾ Check motor shaft fit

²⁾ Min. / Max. permissible motor shaft length

Longer motor shafts are possible, please contact alpha

³⁾ The dimensions depend on the motor

⁴⁾ Smaller motor shaft diameter is compensated

by a bushing with a minimum thickness of 1 mm

⁵⁾ Standard clamping hub diameter

NP 025 MF 1-stage

			1-stage							
Ratio	i		3	4	5	7	8	10		
Max. torque ^{a) b) e)}	T_{2a}	Nm	128	152	160	160	144	144		
		in.lb	1133	1345	1416	1416	1275	1275		
Max. acceleration torque ^{e)} (max. 1000 cycles per hour)	T_{2B}	Nm	80	95	100	100	90	90		
		in.lb	708	841	885	885	797	797		
Emergency stop torque ^{a) b) e)} (permitted 1000 times during the service life of the gearbox)	T_{2Not}	Nm	190	190	190	190	190	190		
		in.lb	1682	1682	1682	1682	1682	1682		
Permitted average input speed ^{d)} (at T_{2N} and 20 °C ambient temperature)	n_{1N}	rpm	3100	3300	3400	3600	3700	3900		
Max. input speed	n_{1Max}	rpm	7000	7000	7000	7000	7000	7000		
Mean no load running torque ^{b)} (at $n_1=3000$ rpm and 20 °C gearbox temperature)	T_{012}	Nm	0.38	0.31	0.26	0.21	0.19	0.17		
		in.lb	3.4	2.7	2.3	1.9	1.7	1.5		
Max. backlash	j_l	arcmin	≤ 8							
Torsional rigidity ^{b)}	C_{i21}	Nm/arcmin	9.5	9.5	9.5	9.5	8.5	8.5		
		in.lb/arcmin	84	84	84	84	75	75		
Max. axial force ^{c)}	F_{2AMax}	N	1900							
		lb _f	428							
Max. lateral force ^{c)}	F_{2QMMax}	N	2800							
		lb _f	630							
Max. tilting moment	M_{2KMMax}	Nm	137							
		in.lb	1213							
Efficiency at full load	η	%	97							
Service life	L_n	h	> 20000							
Weight (incl. standard adapter plate)	m	kg	3.8							
		lb _m	8.4							
Operating noise (at reference ratio and reference speed – ratio-specific values available in cymex®)	L_{PA}	dB(A)	≤ 61							
		°C	+90							
Max. permitted housing temperature		°F	+194							
		°C	-15 to +40							
Ambient temperature		°F	+5 to +104							
			Lubricated for life							
Lubrication			Lubricated for life							
Direction of rotation			In- and output same direction							
Protection class			IP 64							
Elastomer coupling (recommended product type – validate sizing with cymex®)			ELC-0060BA022.000-X							
Bore diameter of coupling on the application side		mm	X = 012.000 - 032.000							
Mass moment of inertia (relates to the drive) Clamping hub diameter [mm]	C	14	J_1	kgcm ²	0.57	0.46	0.37	0.3	0.27	0.25
				10 ⁻³ in.lb.s ²	0.5	0.41	0.33	0.27	0.24	0.22
	D	16	J_1	kgcm ²	0.71	0.61	0.52	0.43	0.42	0.4
				10 ⁻³ in.lb.s ²	0.63	0.54	0.46	0.38	0.37	0.35
	E	19	J_1	kgcm ²	0.8	0.7	0.61	0.53	0.51	0.49
				10 ⁻³ in.lb.s ²	0.71	0.62	0.54	0.47	0.45	0.43
	G	24	J_1	kgcm ²	1.8	1.7	1.6	1.6	1.5	1.5
				10 ⁻³ in.lb.s ²	1.6	1.5	1.4	1.4	1.3	1.3
	H	28	J_1	kgcm ²	1.5	1.4	1.3	1.3	1.2	1.2
				10 ⁻³ in.lb.s ²	1.3	1.2	1.2	1.2	1.1	1.1

Please use our sizing software cymex® for a detailed sizing – www.wittenstein-cymex.com

^{a)} Valid for torque transmission only

^{b)} Valid for standard clamping hub diameter

^{c)} Refers to center of the output shaft or flange

^{d)} Please reduce input speed at higher ambient temperatures

^{e)} Valid for: Smooth shaft

1-stage

up to 19⁴⁾ (E)⁵⁾
clamping hub
diameter

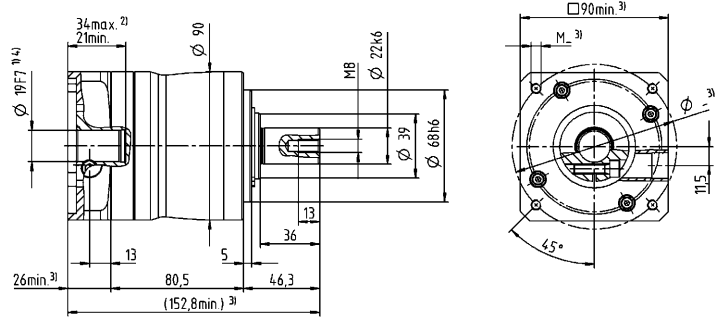
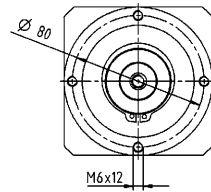

Motor shaft diameter [mm]

up to 28⁴⁾ (H)
clamping hub
diameter

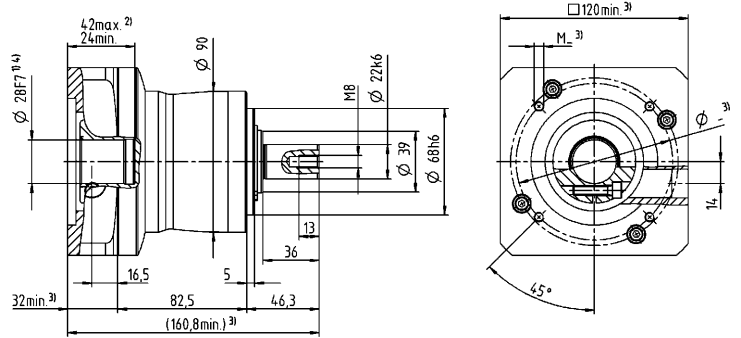
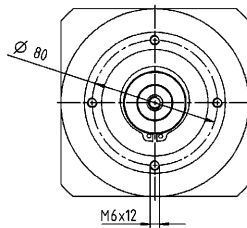

Planetary Gearboxes
Value Line

Other output variants

Shaft with key

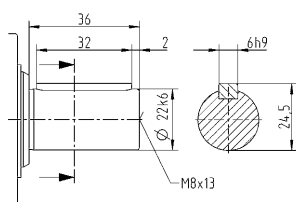

Non-tolerated dimensions are nominal dimensions

¹⁾ Check motor shaft fit

²⁾ Min. / Max. permissible motor shaft length

Longer motor shafts are possible, please contact alpha

³⁾ The dimensions depend on the motor

⁴⁾ Smaller motor shaft diameter is compensated

by a bushing with a minimum thickness of 1 mm

⁵⁾ Standard clamping hub diameter

NP 025 MF 2-stage

			2-stage															
Ratio	i		9	12	15	16	20	25	28	30	32	35	40	50	64	70	100	
Max. torque ^{a) b) e)}	T_{2a}	Nm	128	128	128	152	152	160	152	128	152	160	152	160	144	160	144	
		in.lb	1133	1133	1133	1345	1345	1416	1345	1133	1345	1416	1345	1416	1275	1416	1275	
Max. acceleration torque ^{e)} (max. 1000 cycles per hour)	T_{2B}	Nm	80	80	80	95	95	100	95	80	95	100	95	100	90	100	90	
		in.lb	708	708	708	841	841	885	841	708	841	885	841	885	797	885	797	
Emergency stop torque ^{a) b) e)} (permitted 1000 times during the service life of the gearbox)	T_{2Not}	Nm	190	190	190	190	190	190	190	190	190	190	190	190	190	190	190	
		in.lb	1682	1682	1682	1682	1682	1682	1682	1682	1682	1682	1682	1682	1682	1682	1682	
Permitted average input speed ^{d)} (at T_{2N} and 20 °C ambient temperature)	n_{1N}	rpm	3300	3500	3700	3500	3700	3700	4000	4300	4100	4000	4300	4300	4100	4300	4300	
Max. input speed	n_{1Max}	rpm	8000	8000	8000	8000	8000	8000	8000	8000	8000	8000	8000	8000	8000	8000	8000	
Mean no load running torque ^{b)} (at $n_1=3000$ rpm and 20 °C gearbox temperature)	T_{012}	Nm	0.22	0.18	0.16	0.16	0.15	0.14	0.12	0.12	0.12	0.12	0.11	0.1	0.1	0.1	0.09	
		in.lb	1.9	1.6	1.4	1.4	1.3	1.2	1.1	1.1	1.1	1.1	0.97	0.89	0.89	0.89	0.8	
Max. backlash	j_l	arcmin	≤ 10															
Torsional rigidity ^{b)}	C_{121}	Nm/arcmin	9.5	9.5	9.5	9.5	9.5	9.5	9.5	9.5	9.5	9.5	9.5	9.5	8.5	9.5	8.5	
		in.lb/arcmin	84	84	84	84	84	84	84	84	84	84	84	84	75	84	75	
Max. axial force ^{c)}	F_{2AMax}	N	1900															
		lb _f	428															
Max. lateral force ^{c)}	F_{2QMMax}	N	2800															
		lb _f	630															
Max. tilting moment	M_{2KMMax}	Nm	137															
		in.lb	1213															
Efficiency at full load	η	%	95															
Service life	L_n	h	> 20000															
Weight (incl. standard adapter plate)	m	kg	4.1															
		lb _m	9.1															
Operating noise (at reference ratio and reference speed – ratio-specific values available in cymex [®])	L_{PA}	dB(A)	≤ 59															
Max. permitted housing temperature		°C	+90															
		°F	+194															
Ambient temperature		°C	-15 to +40															
		°F	+5 to +104															
Lubrication			Lubricated for life															
Direction of rotation			In- and output same direction															
Protection class			IP 64															
Elastomer coupling (recommended product type – validate sizing with cymex [®])			ELC-0060BA022.000-X															
Bore diameter of coupling on the application side		mm	X = 012.000 - 032.000															
Mass moment of inertia (relates to the drive) Clamping hub diameter [mm]	A	9	J_1	kgcm ²	0.26	0.22	0.21	0.21	0.2	0.2	0.19	0.19	0.19	0.19	0.19	0.19	0.19	0.19
				10 ⁻³ in.lb.s ²	0.23	0.19	0.19	0.19	0.18	0.18	0.17	0.17	0.17	0.17	0.17	0.17	0.17	0.17
	B	11	J_1	kgcm ²	0.28	0.24	0.23	0.23	0.22	0.22	0.21	0.21	0.21	0.21	0.21	0.21	0.21	0.21
				10 ⁻³ in.lb.s ²	0.25	0.21	0.2	0.2	0.19	0.19	0.19	0.19	0.19	0.19	0.19	0.19	0.19	0.19
	C	14	J_1	kgcm ²	0.35	0.31	0.3	0.3	0.3	0.29	0.29	0.28	0.28	0.28	0.28	0.28	0.28	0.28
				10 ⁻³ in.lb.s ²	0.31	0.27	0.27	0.27	0.27	0.26	0.26	0.25	0.25	0.25	0.25	0.25	0.25	0.25
	D	16	J_1	kgcm ²	0.48	0.44	0.43	0.43	0.42	0.42	0.41	0.41	0.41	0.41	0.41	0.41	0.41	0.41
				10 ⁻³ in.lb.s ²	0.42	0.39	0.38	0.38	0.37	0.37	0.36	0.36	0.36	0.36	0.36	0.36	0.36	0.36
	E	19	J_1	kgcm ²	0.56	0.52	0.51	0.51	0.51	0.5	0.5	0.5	0.5	0.5	0.49	0.49	0.49	0.49
				10 ⁻³ in.lb.s ²	0.5	0.46	0.45	0.45	0.45	0.44	0.44	0.44	0.44	0.44	0.43	0.43	0.43	0.43

Please use our sizing software cymex[®] for a detailed sizing – www.wittenstein-cymex.com

^{a)} Valid for torque transmission only

^{b)} Valid for standard clamping hub diameter

^{c)} Refers to center of the output shaft or flange

^{d)} Please reduce input speed at higher ambient temperatures

^{e)} Valid for: Smooth shaft

2-stage

Motor shaft diameter [mm]

up to 14⁴⁾ (C)⁵⁾
clamping hub diameter

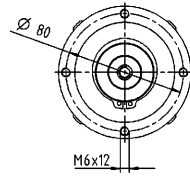

up to 19⁴⁾ (E)
clamping hub diameter

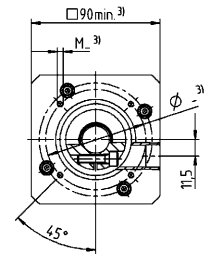
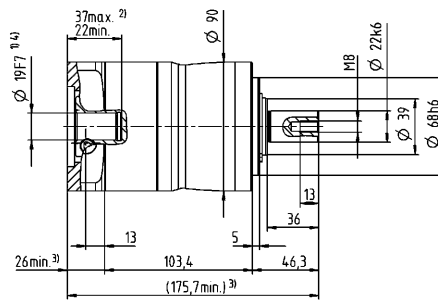
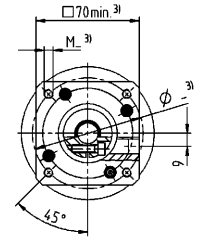
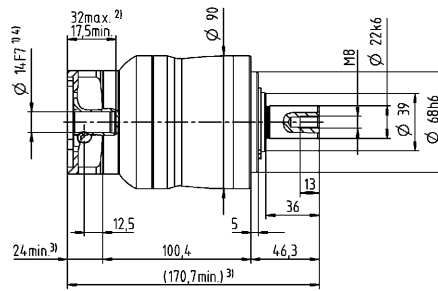
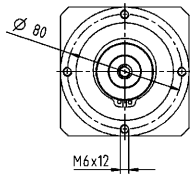

Planetary Gearboxes
Value Line

Other output variants

Shaft with key

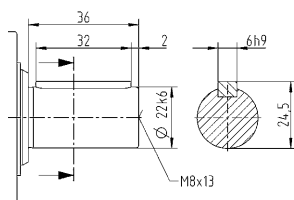

Non-tolerated dimensions are nominal dimensions

¹⁾ Check motor shaft fit

²⁾ Min. / Max. permissible motor shaft length

Longer motor shafts are possible, please contact alpha

³⁾ The dimensions depend on the motor

⁴⁾ Smaller motor shaft diameter is compensated

by a bushing with a minimum thickness of 1 mm

⁵⁾ Standard clamping hub diameter

NP 035 MF 1-stage

			1-stage							
Ratio	i		3	4	5	7	8	10		
Max. torque ^{a) b) e)}	T_{2a}	Nm	320	408	400	400	352	352		
		in.lb	2832	3611	3540	3540	3115	3115		
Max. acceleration torque ^{e)} (max. 1000 cycles per hour)	T_{2B}	Nm	200	255	250	250	220	220		
		in.lb	1770	2257	2213	2213	1947	1947		
Emergency stop torque ^{a) b) e)} (permitted 1000 times during the service life of the gearbox)	T_{2Not}	Nm	500	500	500	500	500	500		
		in.lb	4425	4425	4425	4425	4425	4425		
Permitted average input speed ^{d)} (at T_{2a} and 20 °C ambient temperature)	n_{1N}	rpm	2300	2500	2600	2800	2900	3000		
Max. input speed	n_{1Max}	rpm	6000	6000	6000	6000	6000	6000		
Mean no load running torque ^{b)} (at $n_1=3000$ rpm and 20 °C gearbox temperature)	T_{012}	Nm	1	0.85	0.76	0.66	0.63	0.58		
		in.lb	8.9	7.5	6.7	5.8	5.6	5.1		
Max. backlash	j_l	arcmin	≤ 8							
Torsional rigidity ^{b)}	C_{i21}	Nm/arcmin	22	25	25	25	22	22		
		in.lb/arcmin	195	221	221	221	195	195		
Max. axial force ^{c)}	F_{2AMax}	N	4000							
		lb _f	900							
Max. lateral force ^{c)}	F_{2QMMax}	N	5000							
		lb _f	1125							
Max. tilting moment	M_{2KMMax}	Nm	345							
		in.lb	3054							
Efficiency at full load	η	%	97							
Service life	L_n	h	> 20000							
Weight (incl. standard adapter plate)	m	kg	9.4							
		lb _m	21							
Operating noise (at reference ratio and reference speed – ratio-specific values available in cymex [®])	L_{PA}	dB(A)	≤ 65							
Max. permitted housing temperature		°C	+90							
		°F	+194							
Ambient temperature		°C	-15 to +40							
		°F	+5 to +104							
Lubrication			Lubricated for life							
Direction of rotation			In- and output same direction							
Protection class			IP 64							
Elastomer coupling (recommended product type – validate sizing with cymex [®])			ELC-0150BA032.000-X							
Bore diameter of coupling on the application side		mm	X = 019.000 - 036.000							
Mass moment of inertia (relates to the drive) Clamping hub diameter [mm]	E	19	J_1	kgcm ²	2.6	1.7	1.4	1	1	0.9
				10 ⁻³ in.lb.s ²	2.3	1.5	1.2	0.89	0.89	0.8
	G	24	J_1	kgcm ²	3.4	2.5	2.2	1.8	1.7	1.7
				10 ⁻³ in.lb.s ²	3	2.2	1.9	1.6	1.5	1.5
	H	28	J_1	kgcm ²	3.1	2.2	1.9	1.5	1.4	1.4
				10 ⁻³ in.lb.s ²	2.7	1.9	1.7	1.3	1.2	1.2
	I	32	J_1	kgcm ²	7.2	6.3	5.9	5.6	5.5	5.4
				10 ⁻³ in.lb.s ²	6.4	5.6	5.2	5	4.9	4.8
	K	38	J_1	kgcm ²	8.3	7.4	7.1	6.8	6.7	6.6
				10 ⁻³ in.lb.s ²	7.3	6.5	6.3	6	5.9	5.8

Please use our sizing software cymex[®] for a detailed sizing – www.wittenstein-cymex.com

^{a)} Valid for torque transmission only

^{b)} Valid for standard clamping hub diameter

^{c)} Refers to center of the output shaft or flange

^{d)} Please reduce input speed at higher ambient temperatures

^{e)} Valid for: Smooth shaft

1-stage

Motor shaft diameter [mm]

up to 24/28⁴⁾
(G⁵⁾/H)
clamping hub diameter

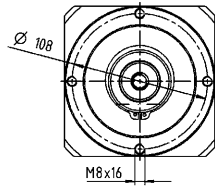

up to 38⁴⁾ (K)
clamping hub diameter

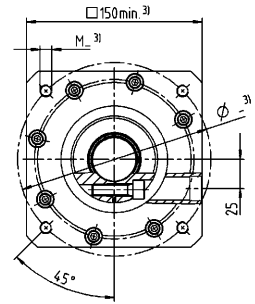
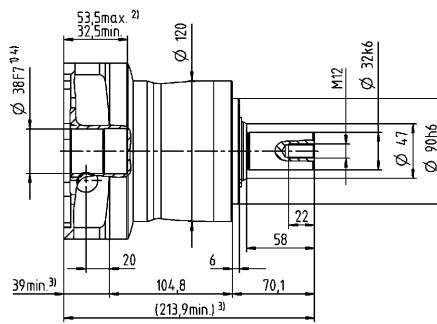
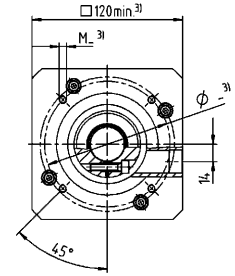
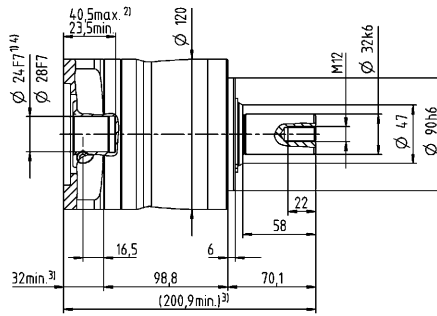
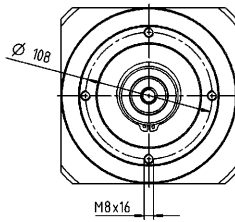

Other output variants

Shaft with key

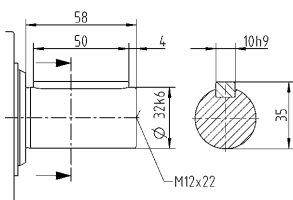

Non-tolerated dimensions are nominal dimensions

¹⁾ Check motor shaft fit

²⁾ Min. / Max. permissible motor shaft length

Longer motor shafts are possible, please contact alpha

³⁾ The dimensions depend on the motor

⁴⁾ Smaller motor shaft diameter is compensated

by a bushing with a minimum thickness of 1 mm

⁵⁾ Standard clamping hub diameter

NP 035 MF 2-stage

			2-stage																
Ratio	i		9	12	15	16	20	25	28	30	32	35	40	50	64	70	100		
Max. torque ^{a) b) e)}	T_{2a}	Nm	320	320	320	408	408	400	408	320	408	400	408	400	352	400	352		
		in.lb	2832	2832	2832	3611	3611	3540	3611	2832	3611	3540	3611	3540	3115	3540	3115		
Max. acceleration torque ^{e)} (max. 1000 cycles per hour)	T_{2B}	Nm	200	200	200	255	255	250	255	200	255	250	255	250	220	250	220		
		in.lb	1770	1770	1770	2257	2257	2213	2257	1770	2257	2213	2257	2213	1947	2213	1947		
Emergency stop torque ^{a) b) e)} (permitted 1000 times during the service life of the gearbox)	T_{2Not}	Nm	500	500	500	500	500	500	500	500	500	500	500	500	500	500	500		
		in.lb	4425	4425	4425	4425	4425	4425	4425	4425	4425	4425	4425	4425	4425	4425	4425		
Permitted average input speed ^{d)} (at T_{2a} and 20 °C ambient temperature)	n_{1N}	rpm	3100	3300	3400	3300	3400	3400	3600	3900	3700	3600	3900	3900	3700	3900	3900		
Max. input speed	n_{1Max}	rpm	7000	7000	7000	7000	7000	7000	7000	7000	7000	7000	7000	7000	7000	7000	7000		
Mean no load running torque ^{b)} (at $n_1=3000$ rpm and 20 °C gearbox temperature)	T_{012}	Nm	0.45	0.36	0.3	0.32	0.27	0.25	0.22	0.19	0.2	0.2	0.18	0.17	0.17	0.16	0.15		
		in.lb	4	3.2	2.7	2.8	2.4	2.2	1.9	1.7	1.8	1.8	1.6	1.5	1.5	1.4	1.3		
Max. backlash	j_l	arcmin	≤ 10																
Torsional rigidity ^{b)}	C_{i21}	Nm/arcmin	22	22	22	25	25	25	25	22	25	25	25	25	22	25	22		
		in.lb/arcmin	195	195	195	221	221	221	221	195	221	221	221	221	195	221	195		
Max. axial force ^{c)}	F_{2AMax}	N	4000																
		lb _f	900																
Max. lateral force ^{c)}	F_{2QMMax}	N	5000																
		lb _f	1125																
Max. tilting moment	M_{2KMMax}	Nm	345																
		in.lb	3054																
Efficiency at full load	η	%	95																
Service life	L_n	h	> 20000																
Weight (incl. standard adapter plate)	m	kg	9.8																
		lb _m	22																
Operating noise (at reference ratio and reference speed – ratio-specific values available in cymex [®])	L_{PA}	dB(A)	≤ 61																
Max. permitted housing temperature		°C	+90																
		°F	+194																
Ambient temperature		°C	-15 to +40																
		°F	+5 to +104																
Lubrication			Lubricated for life																
Direction of rotation			In- and output same direction																
Protection class			IP 64																
Elastomer coupling (recommended product type – validate sizing with cymex [®])			ELC-0150BA032.000-X																
Bore diameter of coupling on the application side		mm	X = 019.000 - 036.000																
Mass moment of inertia (relates to the drive) Clamping hub diameter [mm]	C	14	J_1	kgcm ²	0.61	0.6	0.6	0.43	0.42	0.36	0.37	0.52	0.38	0.32	0.36	0.31	0.26	0.27	0.24
				10 ⁻³ in.lb.s ²	0.54	0.53	0.53	0.38	0.37	0.32	0.33	0.46	0.34	0.28	0.32	0.27	0.23	0.24	0.21
	D	16	J_1	kgcm ²	0.76	0.75	0.75	0.58	0.57	0.5	0.5	0.67	0.52	0.45	0.51	0.46	0.4	0.41	0.39
				10 ⁻³ in.lb.s ²	0.67	0.66	0.66	0.51	0.5	0.44	0.44	0.59	0.46	0.4	0.45	0.41	0.35	0.36	0.35
	E	19	J_1	kgcm ²	0.85	0.83	0.83	0.67	0.66	0.59	0.6	0.75	0.61	0.55	0.6	0.54	0.49	0.5	0.48
				10 ⁻³ in.lb.s ²	0.75	0.73	0.73	0.59	0.58	0.52	0.53	0.66	0.54	0.49	0.53	0.48	0.43	0.44	0.42
	G	24	J_1	kgcm ²	1.9	1.9	1.9	1.7	1.7	1.6	1.6	1.8	1.6	1.6	1.6	1.6	1.5	1.5	1.5
				10 ⁻³ in.lb.s ²	1.7	1.7	1.7	1.5	1.5	1.4	1.4	1.6	1.4	1.4	1.4	1.4	1.3	1.3	1.3
	H	28	J_1	kgcm ²	1.6	1.6	1.6	1.4	1.4	1.3	1.3	1.5	1.4	1.3	1.3	1.3	1.2	1.2	1.2
				10 ⁻³ in.lb.s ²	1.4	1.4	1.4	1.2	1.2	1.2	1.2	1.3	1.2	1.2	1.2	1.2	1.1	1.1	1.1

Please use our sizing software cymex[®] for a detailed sizing – www.wittenstein-cymex.com

^{a)} Valid for torque transmission only

^{b)} Valid for standard clamping hub diameter

^{c)} Refers to center of the output shaft or flange

^{d)} Please reduce input speed at higher ambient temperatures

^{e)} Valid for: Smooth shaft

2-stage

Motor shaft diameter [mm]

up to 19⁴⁾ (E)⁵⁾
clamping hub diameter

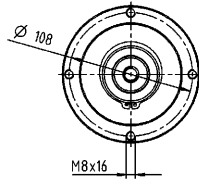

up to 28⁴⁾ (H)
clamping hub diameter

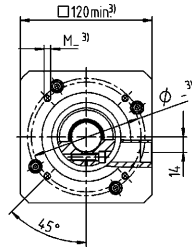
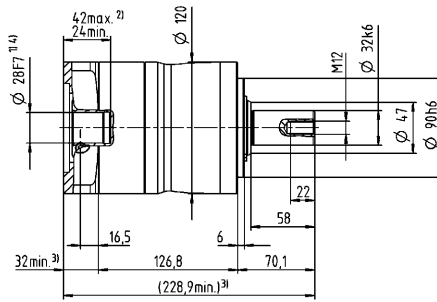
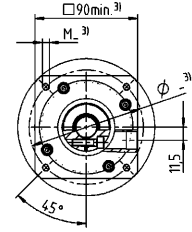
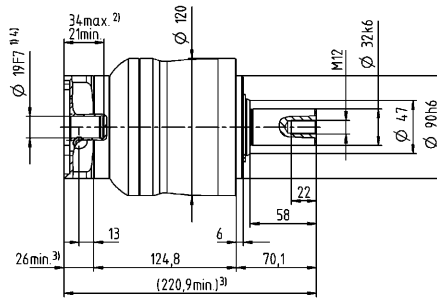
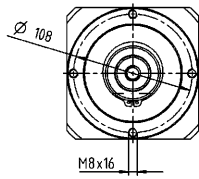

Other output variants

Shaft with key

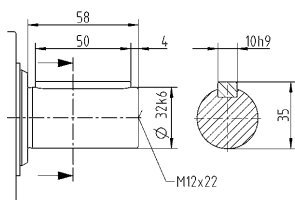

Non-tolerated dimensions are nominal dimensions

¹⁾ Check motor shaft fit

²⁾ Min. / Max. permissible motor shaft length

Longer motor shafts are possible, please contact alpha

³⁾ The dimensions depend on the motor

⁴⁾ Smaller motor shaft diameter is compensated

by a bushing with a minimum thickness of 1 mm

⁵⁾ Standard clamping hub diameter

NP 045 MF 1-/2-stage

			1-stage			2-stage						
Ratio	i		5	8	10	25	32	50	64	100		
Max. torque ^{a) b) e)}	T_{2a}	Nm	800	640	640	700	640	700	640	640		
		in.lb	7081	5665	5665	6196	5665	6196	5665	5665		
Max. acceleration torque ^{e)} (max. 1000 cycles per hour)	T_{2B}	Nm	500	400	400	500	400	500	400	400		
		in.lb	4425	3540	3540	4425	3540	4425	3540	3540		
Emergency stop torque ^{a) b) e)} (permitted 1000 times during the service life of the gearbox)	T_{2Not}	Nm	1000	1000	1000	1000	1000	1000	1000	1000		
		in.lb	8851	8851	8851	8851	8851	8851	8851	8851		
Permitted average input speed ^{d)} (at T_{2a} and 20 °C ambient temperature)	n_{1N}	rpm	2000	2200	2300	2600	2500	3000	2900	3000		
Max. input speed	n_{1Max}	rpm	4000	4000	4000	6000	6000	6000	6000	6000		
Mean no load running torque ^{b)} (at $n_1=3000$ rpm and 20 °C gearbox temperature)	T_{012}	Nm	2.4	2	1.9	0.8	0.68	0.6	0.6	0.55		
		in.lb	21	18	17	7.1	6	5.3	5.3	4.9		
Max. backlash	j_l	arcmin	≤ 8			≤ 10						
Torsional rigidity ^{b)}	C_{i21}	Nm/arcmin	55	44	44	55	55	55	44	44		
		in.lb/arcmin	487	389	389	487	487	487	389	389		
Max. axial force ^{c)}	F_{2AMax}	N	6000			6000						
		lb _f	1350			1350						
Max. lateral force ^{c)}	F_{2QMMax}	N	8000			8000						
		lb _f	1800			1800						
Max. tilting moment	M_{2KMMax}	Nm	704			704						
		in.lb	6231			6231						
Efficiency at full load	η	%	97			95						
Service life	L_n	h	> 20000			> 20000						
Weight (incl. standard adapter plate)	m	kg	19			20						
		lb _m	42			44						
Operating noise (at reference ratio and reference speed – ratio-specific values available in cymex [®])	L_{PA}	dB(A)	≤ 68			≤ 65						
Max. permitted housing temperature		°C	+90			+90						
		°F	+194			+194						
Ambient temperature		°C	-15 to +40			-15 to +40						
		°F	+5 to +104			+5 to +104						
Lubrication			Lubricated for life									
Direction of rotation			In- and output same direction									
Protection class			IP 64									
Elastomer coupling (recommended product type – validate sizing with cymex [®])			ELC-0300BA040.000-X									
Bore diameter of coupling on the application side		mm	X = 020.000 - 045.000									
Mass moment of inertia (relates to the drive) Clamping hub diameter [mm]	E	19	J_1	kgcm ²	-	-	-	1.2	1.1	1.1	0.88	0.82
				10 ⁻³ in.lb.s ²	-	-	-	1.1	0.97	0.97	0.78	0.73
	G	24	J_1	kgcm ²	-	-	-	2	1.9	1.8	1.7	1.6
				10 ⁻³ in.lb.s ²	-	-	-	1.8	1.7	1.6	1.5	1.4
	H	28	J_1	kgcm ²	-	-	-	1.7	1.6	1.5	1.4	1.3
				10 ⁻³ in.lb.s ²	-	-	-	1.5	1.4	1.3	1.2	1.2
	I	32	J_1	kgcm ²	-	-	-	5.8	5.7	5.6	5.4	5.4
				10 ⁻³ in.lb.s ²	-	-	-	5.1	5	5	4.8	4.8
	K	38	J_1	kgcm ²	8.8	7.4	7.2	7	6.9	6.8	6.6	6.5
				10 ⁻³ in.lb.s ²	7.8	6.5	6.4	6.2	6.1	6	5.8	5.8

Please use our sizing software cymex[®] for a detailed sizing – www.wittenstein-cymex.com

^{a)} Valid for torque transmission only

^{b)} Valid for standard clamping hub diameter

^{c)} Refers to center of the output shaft or flange

^{d)} Please reduce input speed at higher ambient temperatures

^{e)} Valid for: Smooth shaft

1-stage

up to 38⁴⁾ (K)⁵⁾
clamping hub
diameter

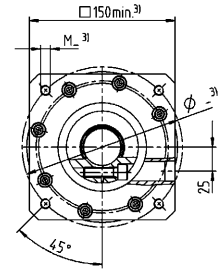
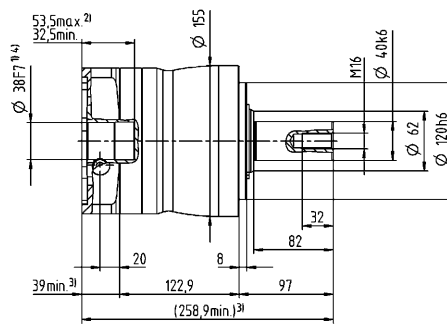
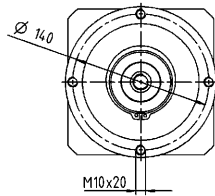

2-stage

up to 28⁴⁾ (H)⁵⁾
clamping hub
diameter

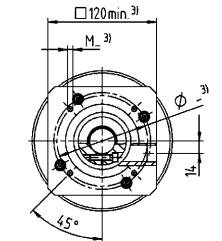
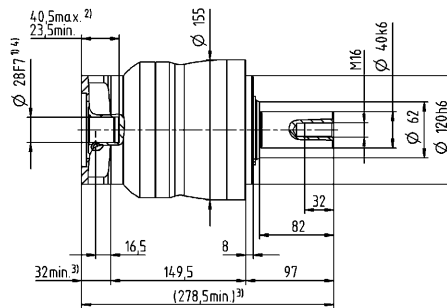
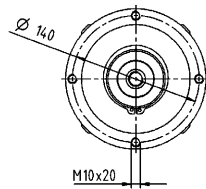

Motor shaft diameter [mm]

up to 38⁴⁾ (K)
clamping hub
diameter

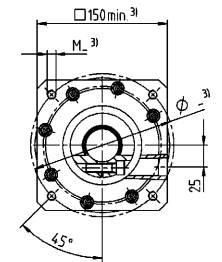
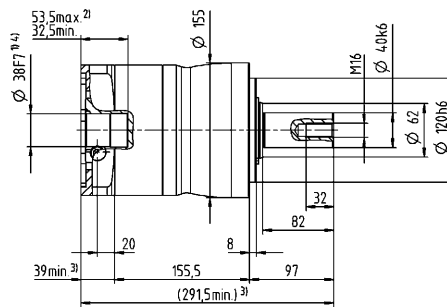
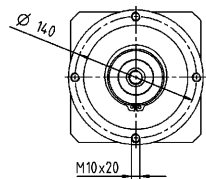

Planetary Gearboxes
Value Line

Other output variants

Shaft with key

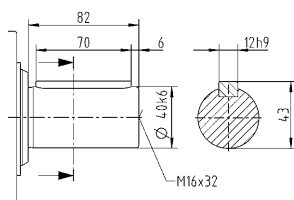

Non-tolerated dimensions are nominal dimensions

¹⁾ Check motor shaft fit

²⁾ Min. / Max. permissible motor shaft length

Longer motor shafts are possible, please contact alpha

³⁾ The dimensions depend on the motor

⁴⁾ Smaller motor shaft diameter is compensated

by a bushing with a minimum thickness of 1 mm

⁵⁾ Standard clamping hub diameter

NP 015 MA 1-/2-stage

			1-stage		2-stage							
Ratio	i		3	4	12	15	16	20	28	30	40	
Max. torque ^{a) b) e)}	T_{2a}	Nm	80	67	62	67	67	67	67	62	67	
		in.lb	708	593	549	593	593	593	593	593	549	593
Max. acceleration torque ^{e)} (max. 1000 cycles per hour)	T_{2B}	Nm	55	42	39	42	42	42	42	42	39	42
		in.lb	487	372	345	372	372	372	372	372	345	372
Emergency stop torque ^{a) b) e)} (permitted 1000 times during the service life of the gearbox)	T_{2Not}	Nm	80	80	80	80	80	80	80	80	80	80
		in.lb	708	708	708	708	708	708	708	708	708	708
Permitted average input speed ^{d)} (at T_{2N} and 20 °C ambient temperature)	n_{1N}	rpm	3300	3500	3800	4000	3800	4000	4300	4600	4600	
Max. input speed	n_{1Max}	rpm	8000	8000	10000	10000	10000	10000	10000	10000	10000	
Mean no load running torque ^{b)} (at $n_1=3000$ rpm and 20 °C gearbox temperature)	T_{012}	Nm	0.24	0.2	0.13	0.11	0.12	0.11	0.09	0.09	0.08	
		in.lb	2.1	1.8	1.2	0.97	1.1	0.97	0.8	0.8	0.71	
Max. backlash	j_l	arcmin	≤ 8		≤ 10							
Torsional rigidity ^{b)}	C_{121}	Nm/arcmin	4	4	4	4	4	4	4	4	4	
		in.lb/arcmin	35	35	35	35	35	35	35	35	35	
Max. axial force ^{c)}	F_{2AMax}	N	1550		1550							
		lb _f	349		349							
Max. lateral force ^{c)}	F_{2QMMax}	N	1700		1700							
		lb _f	383		383							
Max. tilting moment	M_{2KMMax}	Nm	72		72							
		in.lb	637		637							
Efficiency at full load	η	%	97		95							
Service life	L_n	h	> 20000		> 20000							
Weight (incl. standard adapter plate)	m	kg	1.9		1.9							
		lb _m	4.2		4.2							
Operating noise (at reference ratio and reference speed – ratio-specific values available in cymex®)	L_{PA}	dB(A)	≤ 59		≤ 58							
Max. permitted housing temperature		°C	+90		+90							
		°F	+194		+194							
Ambient temperature		°C	-15 to +40		-15 to +40							
		°F	+5 to +104		+5 to +104							
Lubrication			Lubricated for life									
Direction of rotation			In- and output same direction									
Protection class			IP 64									
Elastomer coupling (recommended product type – validate sizing with cymex®)			ELC-0060BA016.000-X									
Bore diameter of coupling on the application side		mm	X = 012.000 - 032.000									
Mass moment of inertia (relates to the drive) Clamping hub diameter [mm]	Z	8	J_1	kgcm ²	-	-	0.04	0.04	0.03	0.03	0.03	0.03
				10 ⁻³ in.lb.s ²	-	-	0.04	0.04	0.03	0.03	0.03	0.03
	A	9	J_1	kgcm ²	0.22	0.18	0.04	0.04	0.03	0.03	0.03	0.03
				10 ⁻³ in.lb.s ²	0.19	0.16	0.04	0.04	0.03	0.03	0.03	0.03
	B	11	J_1	kgcm ²	0.24	0.19	0.06	0.05	0.05	0.05	0.05	0.05
				10 ⁻³ in.lb.s ²	0.21	0.17	0.05	0.04	0.04	0.04	0.04	0.04
	C	14	J_1	kgcm ²	0.32	0.27	0.14	0.14	0.14	0.13	0.13	0.14
				10 ⁻³ in.lb.s ²	0.28	0.24	0.12	0.12	0.12	0.12	0.12	0.12
	D	16	J_1	kgcm ²	0.45	0.4	-	-	-	-	-	-
				10 ⁻³ in.lb.s ²	0.4	0.35	-	-	-	-	-	-
	E	19	J_1	kgcm ²	0.53	0.48	-	-	-	-	-	-
				10 ⁻³ in.lb.s ²	0.47	0.42	-	-	-	-	-	-

Please use our sizing software cymex® for a detailed sizing – www.wittenstein-cymex.com

^{a)} Valid for torque transmission only

^{b)} Valid for standard clamping hub diameter

^{c)} Refers to center of the output shaft or flange

^{d)} Please reduce input speed at higher ambient temperatures

^{e)} Valid for: Smooth shaft

1-stage

up to 14⁴⁾ (C)⁵⁾
clamping hub diameter

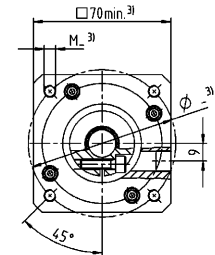
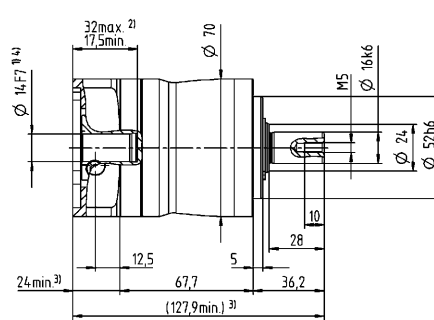
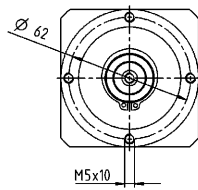

up to 19⁴⁾ (E)
clamping hub diameter

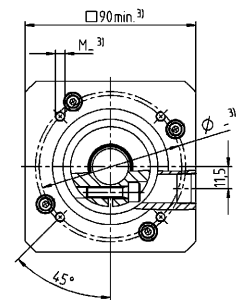
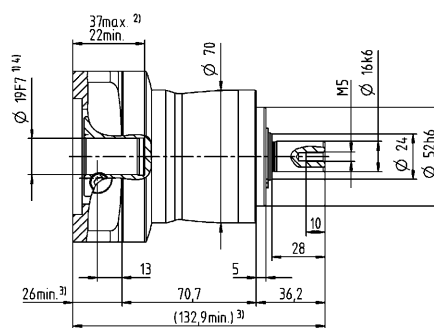
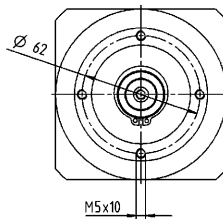

2-stage

up to 11⁴⁾ (B)⁵⁾
clamping hub diameter

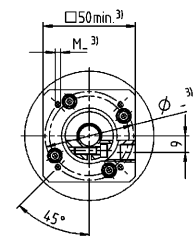
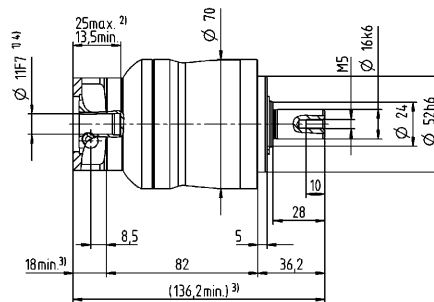
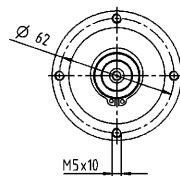

up to 14⁴⁾ (C)
clamping hub diameter

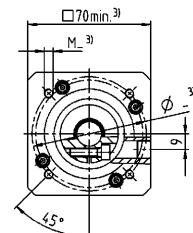
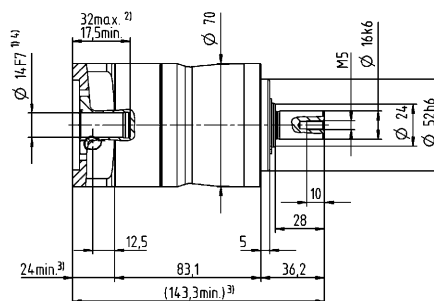
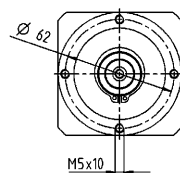

Motor shaft diameter [mm]

Other output variants

Shaft with key

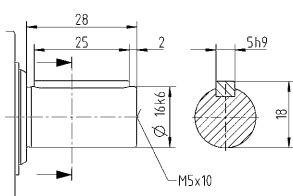

Non-tolerated dimensions are nominal dimensions

¹⁾ Check motor shaft fit

²⁾ Min. / Max. permissible motor shaft length

Longer motor shafts are possible, please contact alpha

³⁾ The dimensions depend on the motor

⁴⁾ Smaller motor shaft diameter is compensated

by a bushing with a minimum thickness of 1 mm

⁵⁾ Standard clamping hub diameter

NP 025 MA 1-/2-stage

			1-stage		2-stage									
Ratio	i		3	4	9	12	15	16	20	28	30	40		
Max. torque ^{a) b) e)}	T_{2a}	Nm	185	185	185	185	185	185	185	185	168	185		
		in.lb	1637	1637	1637	1637	1637	1637	1637	1637	1637	1487	1637	
Max. acceleration torque ^{e)} (max. 1000 cycles per hour)	T_{2B}	Nm	125	115	125	125	120	115	115	115	105	115		
		in.lb	1106	1018	1106	1106	1062	1018	1018	1018	929	1018		
Emergency stop torque ^{a) b) e)} (permitted 1000 times during the service life of the gearbox)	T_{2Not}	Nm	190	190	190	190	190	190	190	190	190	190		
		in.lb	1682	1682	1682	1682	1682	1682	1682	1682	1682	1682		
Permitted average input speed ^{d)} (at T_{2N} and 20 °C ambient temperature)	n_{1N}	rpm	3100	3300	3300	3500	3700	3500	3700	4000	4300	4300		
Max. input speed	n_{1Max}	rpm	7000	7000	8000	8000	8000	8000	8000	8000	8000	8000		
Mean no load running torque ^{b)} (at $n_1=3000$ rpm and 20 °C gearbox temperature)	T_{012}	Nm	0.38	0.31	0.22	0.18	0.16	0.16	0.15	0.12	0.12	0.11		
		in.lb	3.4	2.7	1.9	1.6	1.4	1.4	1.3	1.1	1.1	0.97		
Max. backlash	j_l	arcmin	≤ 8		≤ 10									
Torsional rigidity ^{b)}	C_{i21}	Nm/arcmin	12	12	12	12	12	12	12	10	12	12		
		in.lb/arcmin	106	106	106	106	106	106	106	89	106	106		
Max. axial force ^{c)}	F_{2AMax}	N	1900		1900									
		lb _f	428		428									
Max. lateral force ^{c)}	F_{2QMMax}	N	2800		2800									
		lb _f	630		630									
Max. tilting moment	M_{2KMMax}	Nm	137		137									
		in.lb	1213		1213									
Efficiency at full load	η	%	97		95									
Service life	L_n	h	> 20000		> 20000									
Weight (incl. standard adapter plate)	m	kg	3.8		4.1									
		lb _m	8.4		9.1									
Operating noise (at reference ratio and reference speed – ratio-specific values available in cymex®)	L_{PA}	dB(A)	≤ 61		≤ 59									
			°C		+90		+90							
Max. permitted housing temperature			°F		+194		+194							
			°C		-15 to +40		-15 to +40							
Ambient temperature			°F		+5 to +104		+5 to +104							
			Lubricated for life											
Direction of rotation		In- and output same direction												
Protection class		IP 64												
Elastomer coupling (recommended product type – validate sizing with cymex®)		ELC-0060BA022.000-X												
Bore diameter of coupling on the application side		mm	X = 012.000 - 032.000											
Mass moment of inertia (relates to the drive) Clamping hub diameter [mm]	A	9	J_1	kgcm ²	-	-	0.26	0.22	0.21	0.21	0.2	0.19	0.19	0.19
				10 ⁻³ in.lb.s ²	-	-	0.23	0.19	0.19	0.19	0.18	0.17	0.17	0.17
	B	11	J_1	kgcm ²	-	-	0.28	0.24	0.23	0.23	0.22	0.21	0.21	0.21
				10 ⁻³ in.lb.s ²	-	-	0.25	0.21	0.2	0.2	0.19	0.19	0.19	0.19
	C	14	J_1	kgcm ²	0.57	0.46	0.35	0.31	0.3	0.3	0.3	0.29	0.28	0.28
				10 ⁻³ in.lb.s ²	0.5	0.41	0.31	0.27	0.27	0.27	0.27	0.26	0.25	0.25
	D	16	J_1	kgcm ²	0.71	0.61	0.48	0.44	0.43	0.43	0.42	0.41	0.41	0.41
				10 ⁻³ in.lb.s ²	0.63	0.54	0.42	0.39	0.38	0.38	0.37	0.36	0.36	0.36
	E	19	J_1	kgcm ²	0.8	0.7	0.56	0.52	0.51	0.51	0.51	0.5	0.5	0.49
				10 ⁻³ in.lb.s ²	0.71	0.62	0.5	0.46	0.45	0.45	0.45	0.44	0.44	0.43
	G	24	J_1	kgcm ²	1.8	1.7	-	-	-	-	-	-	-	-
				10 ⁻³ in.lb.s ²	1.6	1.5	-	-	-	-	-	-	-	-
	H	28	J_1	kgcm ²	1.5	1.4	-	-	-	-	-	-	-	-
				10 ⁻³ in.lb.s ²	1.3	1.2	-	-	-	-	-	-	-	-

Please use our sizing software cymex® for a detailed sizing – www.wittenstein-cymex.com

^{a)} Valid for torque transmission only

^{b)} Valid for standard clamping hub diameter

^{c)} Refers to center of the output shaft or flange

^{d)} Please reduce input speed at higher ambient temperatures

^{e)} Valid for: Smooth shaft

1-stage

up to 19⁴⁾ (E)⁵⁾
clamping hub diameter

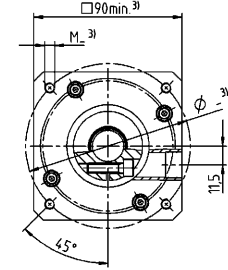
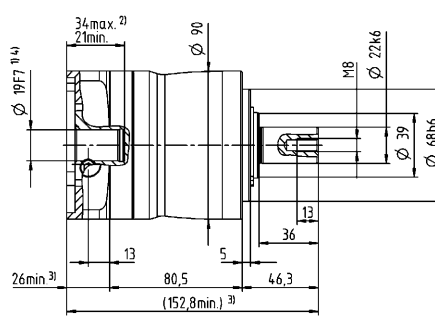
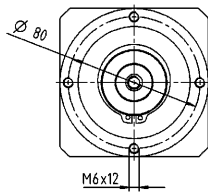

up to 28⁴⁾ (H)
clamping hub diameter

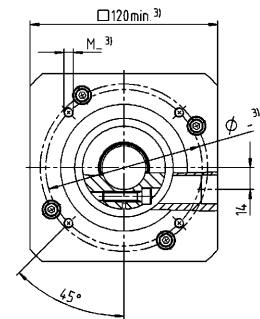
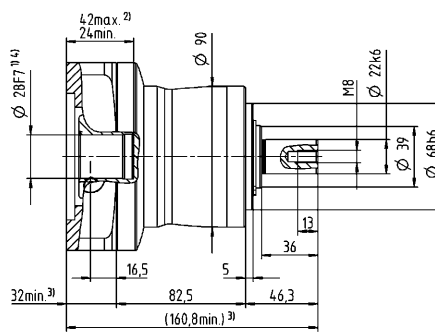
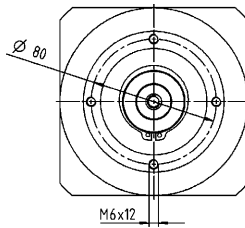

2-stage

up to 14⁴⁾ (C)⁵⁾
clamping hub diameter

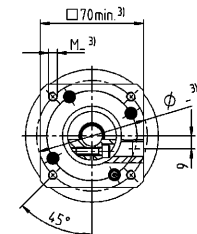
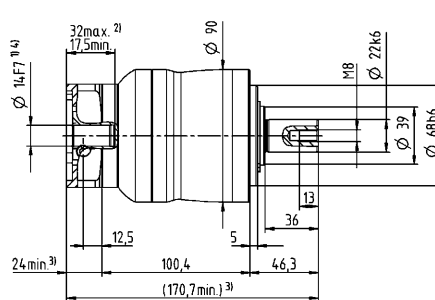
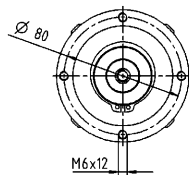

up to 19⁴⁾ (E)
clamping hub diameter

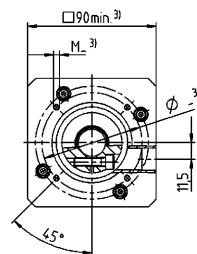
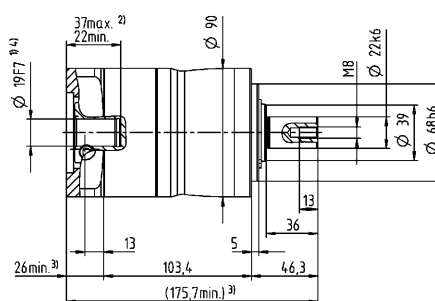
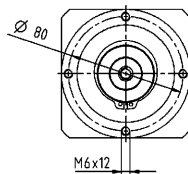

Motor shaft diameter [mm]

Other output variants

Shaft with key

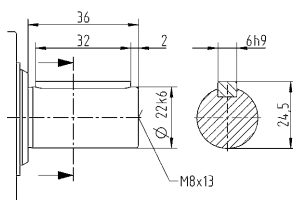

Non-tolerated dimensions are nominal dimensions

¹⁾ Check motor shaft fit

²⁾ Min. / Max. permissible motor shaft length

Longer motor shafts are possible, please contact alpha

³⁾ The dimensions depend on the motor

⁴⁾ Smaller motor shaft diameter is compensated

by a bushing with a minimum thickness of 1 mm

⁵⁾ Standard clamping hub diameter

NP 035 MA 1-/2-stage

			1-stage		2-stage									
Ratio	i		3	4	9	12	15	16	20	28	30	40		
Max. torque ^{a) b) e)}	T_{2a}	Nm	480	480	480	480	480	480	480	480	432	480		
		in.lb	4248	4248	4248	4248	4248	4248	4248	4248	4248	3824	4248	
Max. acceleration torque ^{e)} (max. 1000 cycles per hour)	T_{2B}	Nm	305	305	305	305	300	305	305	305	270	305		
		in.lb	2699	2699	2699	2699	2655	2699	2699	2699	2390	2699		
Emergency stop torque ^{a) b) e)} (permitted 1000 times during the service life of the gearbox)	T_{2Not}	Nm	500	500	500	500	500	500	500	500	500	500		
		in.lb	4425	4425	4425	4425	4425	4425	4425	4425	4425	4425		
Permitted average input speed ^{d)} (at T_{2N} and 20 °C ambient temperature)	n_{1N}	rpm	2300	2500	3100	3300	3400	3300	3400	3600	3900	3900		
Max. input speed	n_{1Max}	rpm	6000	6000	7000	7000	7000	7000	7000	7000	7000	7000		
Mean no load running torque ^{b)} (at $n_i=3000$ rpm and 20 °C gearbox temperature)	T_{012}	Nm	1	0.85	0.45	0.36	0.3	0.32	0.27	0.22	0.19	0.18		
		in.lb	8.9	7.5	4	3.2	2.7	2.8	2.4	1.9	1.7	1.6		
Max. backlash	j_l	arcmin	≤ 8		≤ 10									
Torsional rigidity ^{b)}	C_{i21}	Nm/arcmin	30	30	30	30	30	30	30	30	30	30		
		in.lb/arcmin	266	266	266	266	266	266	266	266	266	266		
Max. axial force ^{c)}	F_{2AMax}	N	4000		4000									
		lb _f	900		900									
Max. lateral force ^{c)}	F_{2QMMax}	N	5000		5000									
		lb _f	1125		1125									
Max. tilting moment	M_{2KMMax}	Nm	345		345									
		in.lb	3054		3054									
Efficiency at full load	η	%	97		95									
Service life	L_n	h	> 20000		> 20000									
Weight (incl. standard adapter plate)	m	kg	9.4		9.8									
		lb _m	21		22									
Operating noise (at reference ratio and reference speed – ratio-specific values available in cymex®)	L_{PA}	dB(A)	≤ 65		≤ 61									
			°C		+90		+90							
Max. permitted housing temperature			°F		+194		+194							
			°C		-15 to +40		-15 to +40							
Ambient temperature			°F		+5 to +104		+5 to +104							
			Lubricated for life											
Direction of rotation		In- and output same direction												
Protection class		IP 64												
Elastomer coupling (recommended product type – validate sizing with cymex®)		ELC-0150BA032.000-X												
Bore diameter of coupling on the application side		mm	X = 019.000 - 036.000											
Mass moment of inertia (relates to the drive) Clamping hub diameter [mm]	C	14	J_1	kgcm ²	-	-	0.61	0.6	0.6	0.43	0.42	0.37	0.52	0.36
				10 ⁻³ in.lb.s ²	-	-	0.54	0.53	0.53	0.38	0.37	0.33	0.46	0.32
	D	16	J_1	kgcm ²	-	-	0.76	0.75	0.75	0.58	0.57	0.5	0.67	0.51
				10 ⁻³ in.lb.s ²	-	-	0.67	0.66	0.66	0.51	0.5	0.44	0.59	0.45
	E	19	J_1	kgcm ²	2.6	1.7	0.85	0.83	0.83	0.67	0.66	0.6	0.75	0.6
				10 ⁻³ in.lb.s ²	2.3	1.5	0.75	0.73	0.73	0.59	0.58	0.53	0.66	0.53
	G	24	J_1	kgcm ²	3.4	2.5	1.9	1.9	1.9	1.7	1.7	1.6	1.8	1.6
				10 ⁻³ in.lb.s ²	3	2.2	1.7	1.7	1.7	1.5	1.5	1.4	1.6	1.4
	H	28	J_1	kgcm ²	3.1	2.2	1.6	1.6	1.6	1.4	1.4	1.3	0.5	1.3
				10 ⁻³ in.lb.s ²	2.7	1.9	1.4	1.4	1.4	1.2	1.2	1.2	0.44	1.2
	I	32	J_1	kgcm ²	7.2	6.3	-	-	-	-	-	-	-	-
				10 ⁻³ in.lb.s ²	6.4	5.6	-	-	-	-	-	-	-	-
K	38	J_1	kgcm ²	8.3	7.4	-	-	-	-	-	-	-	-	
			10 ⁻³ in.lb.s ²	7.3	6.5	-	-	-	-	-	-	-	-	

Please use our sizing software cymex® for a detailed sizing – www.wittenstein-cymex.com

^{a)} Valid for torque transmission only

^{b)} Valid for standard clamping hub diameter

^{c)} Refers to center of the output shaft or flange

^{d)} Please reduce input speed at higher ambient temperatures

^{e)} Valid for: Smooth shaft

1-stage

up to 24/28⁴⁾
(G⁵⁾/H)
clamping hub
diameter

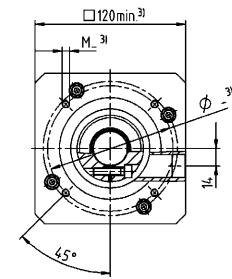
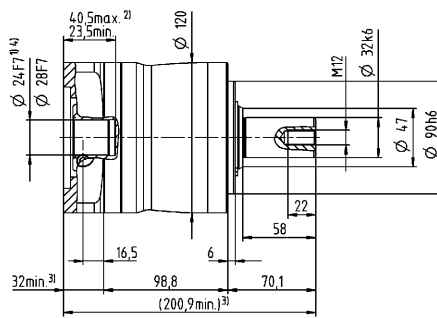
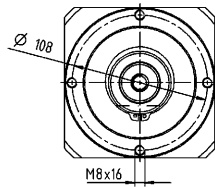

up to 38⁴⁾ (K)
clamping hub
diameter

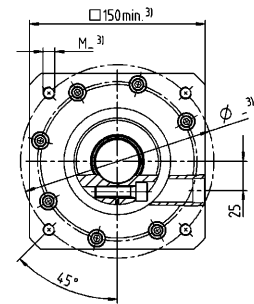
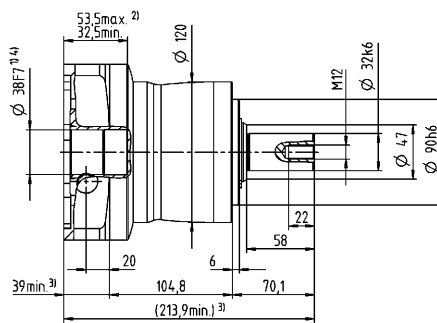
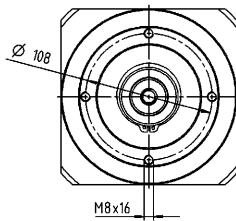

2-stage

up to 19⁴⁾ (E)⁵⁾
clamping hub
diameter

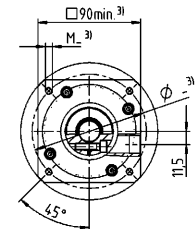
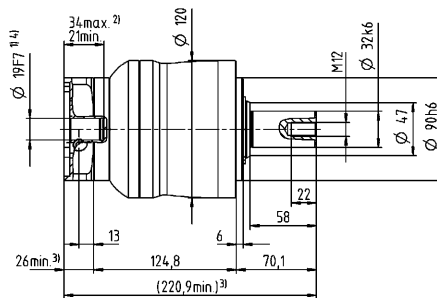
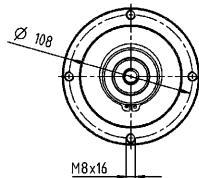

up to 28⁴⁾ (H)
clamping hub
diameter

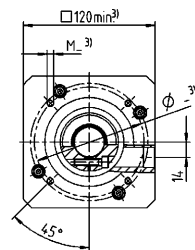
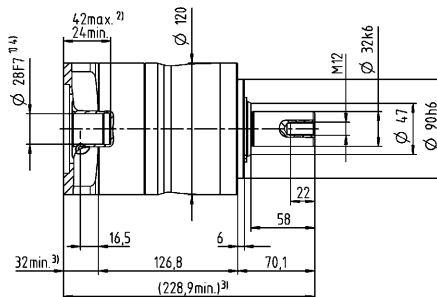
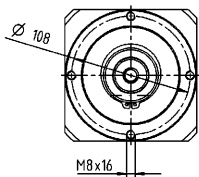

Motor shaft diameter [mm]

Other output variants

Shaft with key

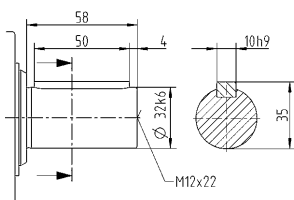

Non-tolerated dimensions are nominal dimensions

¹⁾ Check motor shaft fit

²⁾ Min. / Max. permissible motor shaft length

Longer motor shafts are possible, please contact alpha

³⁾ The dimensions depend on the motor

⁴⁾ Smaller motor shaft diameter is compensated

by a bushing with a minimum thickness of 1 mm

⁵⁾ Standard clamping hub diameter

NPL 015 MF 1-stage

			1-stage							
Ratio	i		3	4	5	7	8	10		
Max. torque ^{a) b) e)}	T_{2a}	Nm	51	56	64	64	56	56		
		in.lb	451	496	566	566	496	496		
Max. acceleration torque ^{e)} (max. 1000 cycles per hour)	T_{2B}	Nm	32	35	40	40	35	35		
		in.lb	283	310	354	354	310	310		
Emergency stop torque ^{a) b) e)} (permitted 1000 times during the service life of the gearbox)	T_{2Not}	Nm	80	80	80	80	80	80		
		in.lb	708	708	708	708	708	708		
Permitted average input speed ^{d)} (at T_{2N} and 20 °C ambient temperature)	n_{1N}	rpm	2900	3100	3300	3600	3600	3800		
Max. input speed	n_{1Max}	rpm	8000	8000	8000	8000	8000	8000		
Mean no load running torque ^{b)} (at $n_1=3000$ rpm and 20 °C gearbox temperature)	T_{012}	Nm	0.92	0.74	0.62	0.51	0.47	0.41		
		in.lb	8.1	6.5	5.5	4.5	4.2	3.6		
Max. backlash	j_l	arcmin	≤ 8							
Torsional rigidity ^{b)}	C_{i21}	Nm/arcmin	3.3	3.3	3.3	3.3	2.8	2.8		
		in.lb/arcmin	29	29	29	29	25	25		
Max. axial force ^{c)}	F_{2AMax}	N	2400							
		lb _f	540							
Max. lateral force ^{c)}	F_{2QMMax}	N	2800							
		lb _f	630							
Max. tilting moment	M_{2KMMax}	Nm	152							
		in.lb	1345							
Efficiency at full load	η	%	97							
Service life	L_n	h	> 20000							
Weight (incl. standard adapter plate)	m	kg	1.9							
		lb _m	4.2							
Operating noise (at reference ratio and reference speed – ratio-specific values available in cymex [®])	L_{PA}	dB(A)	≤ 59							
Max. permitted housing temperature		°C	+90							
		°F	+194							
Ambient temperature		°C	-15 to +40							
		°F	+5 to +104							
Lubrication			Lubricated for life							
Direction of rotation			In- and output same direction							
Protection class			IP 65							
Elastomer coupling (recommended product type – validate sizing with cymex [®])			ELC-0060BA016.000-X							
Bore diameter of coupling on the application side		mm	X = 012.000 - 032.000							
Mass moment of inertia (relates to the drive) Clamping hub diameter [mm]	A	9	J_1	kgcm ²	0.25	0.19	0.17	0.14	0.14	0.13
				10 ⁻³ in.lb.s ²	0.22	0.17	0.15	0.12	0.12	0.12
	B	11	J_1	kgcm ²	0.26	0.21	0.18	0.16	0.16	0.15
				10 ⁻³ in.lb.s ²	0.23	0.19	0.16	0.14	0.14	0.13
	C	14	J_1	kgcm ²	0.34	0.28	0.26	0.24	0.23	0.23
				10 ⁻³ in.lb.s ²	0.3	0.25	0.23	0.21	0.2	0.2
	D	16	J_1	kgcm ²	0.47	0.41	0.39	0.36	0.36	0.35
				10 ⁻³ in.lb.s ²	0.42	0.36	0.35	0.32	0.32	0.31
	E	19	J_1	kgcm ²	0.55	0.49	0.47	0.45	0.44	0.44
				10 ⁻³ in.lb.s ²	0.49	0.43	0.42	0.4	0.39	0.39

Please use our sizing software cymex[®] for a detailed sizing – www.wittenstein-cymex.com

^{a)} Valid for torque transmission only

^{b)} Valid for standard clamping hub diameter

^{c)} Refers to center of the output shaft or flange

^{d)} Please reduce input speed at higher ambient temperatures

^{e)} Valid for: Smooth shaft

1-stage

Motor shaft diameter [mm]

up to 14⁴⁾ (C)⁵⁾
clamping hub diameter

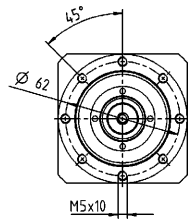

up to 19⁴⁾ (E)
clamping hub diameter

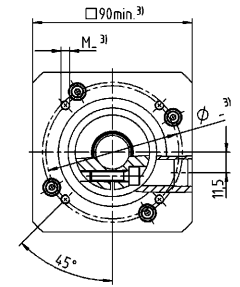
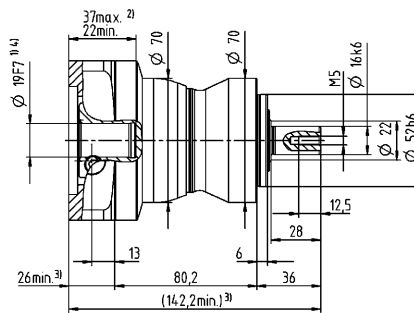
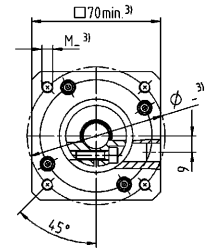
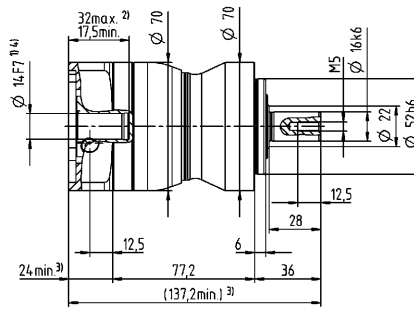
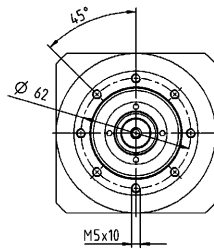

Planetary Gearboxes
Value Line

Other output variants

Shaft with key

Splined shaft (DIN 5480)

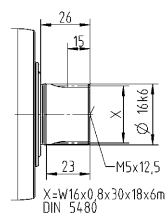
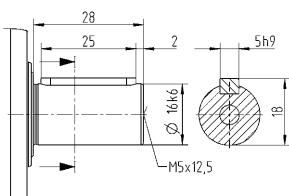

Non-tolerated dimensions are nominal dimensions

¹⁾ Check motor shaft fit

²⁾ Min. / Max. permissible motor shaft length

Longer motor shafts are possible, please contact alpha

³⁾ The dimensions depend on the motor

⁴⁾ Smaller motor shaft diameter is compensated

by a bushing with a minimum thickness of 1 mm

⁵⁾ Standard clamping hub diameter

NPL 015 MF 2-stage

			2-stage														
Ratio	i		12	15	16	20	25	28	30	32	35	40	50	64	70	100	
Max. torque ^{a) b) e)}	T_{2a}	Nm	51	51	56	56	64	56	51	56	64	56	64	56	64	56	
		in.lb	451	451	496	496	566	496	451	496	566	496	566	496	566	496	566
Max. acceleration torque ^{e)} (max. 1000 cycles per hour)	T_{2B}	Nm	32	32	35	35	40	35	32	35	40	35	40	35	40	35	
		in.lb	283	283	310	310	354	310	283	310	354	310	354	310	354	310	
Emergency stop torque ^{a) b) e)} (permitted 1000 times during the service life of the gearbox)	T_{2Not}	Nm	80	80	80	80	80	80	80	80	80	80	80	80	80	80	
		in.lb	708	708	708	708	708	708	708	708	708	708	708	708	708	708	
Permitted average input speed ^{d)} (at T_{2N} and 20 °C ambient temperature)	n_{1N}	rpm	3800	4000	3800	4000	4000	4300	4600	4400	4300	4600	4600	4400	4600	4600	
Max. input speed	n_{1Max}	rpm	10000	10000	10000	10000	10000	10000	10000	10000	10000	10000	10000	10000	10000	10000	
Mean no load running torque ^{b)} (at $n_1=3000$ rpm and 20 °C gearbox temperature)	T_{012}	Nm	0.34	0.29	0.29	0.25	0.23	0.21	0.21	0.2	0.2	0.19	0.17	0.17	0.16	0.15	
		in.lb	3	2.6	2.6	2.2	2	1.9	1.9	1.8	1.8	1.7	1.5	1.5	1.4	1.3	
Max. backlash	j_l	arcmin	≤ 10														
Torsional rigidity ^{b)}	C_{i21}	Nm/arcmin	3.3	3.3	3.3	3.3	3.3	3.3	3.3	3.3	3.3	3.3	3.3	2.8	3.3	2.8	
		in.lb/arcmin	29	29	29	29	29	29	29	29	29	29	29	25	29	25	
Max. axial force ^{c)}	F_{2AMax}	N	2400														
		lb _f	540														
Max. lateral force ^{c)}	F_{2QMMax}	N	2800														
		lb _f	630														
Max. tilting moment	M_{2KMMax}	Nm	152														
		in.lb	1345														
Efficiency at full load	η	%	95														
Service life	L_n	h	> 20000														
Weight (incl. standard adapter plate)	m	kg	2														
		lb _m	4.4														
Operating noise (at reference ratio and reference speed – ratio-specific values available in cymex [®])	L_{PA}	dB(A)	≤ 58														
Max. permitted housing temperature		°C	+90														
		°F	+194														
Ambient temperature		°C	-15 to +40														
		°F	+5 to +104														
Lubrication			Lubricated for life														
Direction of rotation			In- and output same direction														
Protection class			IP 65														
Elastomer coupling (recommended product type – validate sizing with cymex [®])			ELC-0060BA016.000-X														
Bore diameter of coupling on the application side		mm	X = 012.000 - 032.000														
Mass moment of inertia (relates to the drive) Clamping hub diameter [mm]	Z	8	J_1	kgcm ²	0.04	0.04	0.03	0.03	0.03	0.03	0.03	0.03	0.03	0.02	0.02	0.02	0.02
				10 ⁻³ in.lb.s ²	0.04	0.04	0.03	0.03	0.03	0.03	0.03	0.03	0.03	0.03	0.02	0.02	0.02
	A	9	J_1	kgcm ²	0.04	0.04	0.03	0.03	0.03	0.03	0.03	0.03	0.03	0.02	0.02	0.02	0.02
				10 ⁻³ in.lb.s ²	0.04	0.04	0.03	0.03	0.03	0.03	0.03	0.03	0.03	0.02	0.02	0.02	0.02
	B	11	J_1	kgcm ²	0.06	0.06	0.05	0.05	0.05	0.05	0.05	0.04	0.05	0.04	0.04	0.04	
				10 ⁻³ in.lb.s ²	0.05	0.05	0.04	0.04	0.04	0.04	0.04	0.04	0.04	0.04	0.04	0.04	
	C	14	J_1	kgcm ²	0.14	0.14	0.14	0.13	0.13	0.13	0.14	0.13	0.13	0.13	0.13	0.13	
				10 ⁻³ in.lb.s ²	0.12	0.12	0.12	0.12	0.12	0.12	0.12	0.12	0.12	0.12	0.12	0.12	

Please use our sizing software cymex[®] for a detailed sizing – www.wittenstein-cymex.com

^{a)} Valid for torque transmission only

^{b)} Valid for standard clamping hub diameter

^{c)} Refers to center of the output shaft or flange

^{d)} Please reduce input speed at higher ambient temperatures

^{e)} Valid for: Smooth shaft

2-stage

Motor shaft diameter [mm]

up to 11⁴⁾ (B)⁵⁾
clamping hub diameter

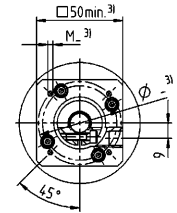
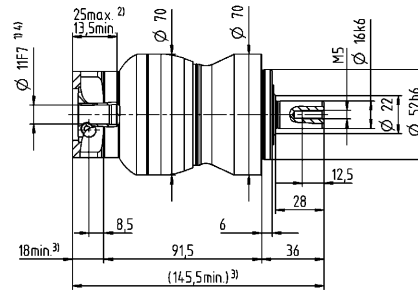
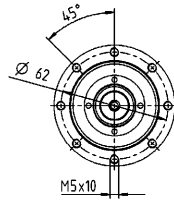

up to 14⁴⁾ (C)
clamping hub diameter

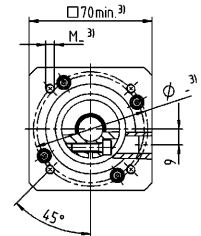
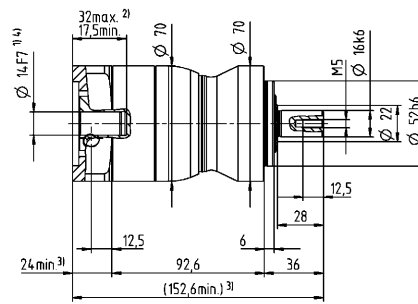
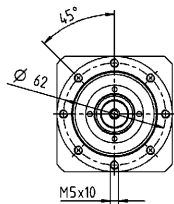

Planetary Gearboxes
Value Line

Other output variants

Shaft with key

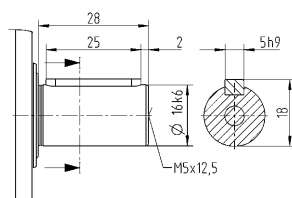

Splined shaft (DIN 5480)

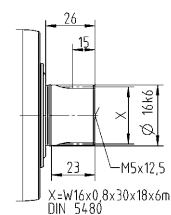

Non-tolerated dimensions are nominal dimensions

¹⁾ Check motor shaft fit

²⁾ Min. / Max. permissible motor shaft length

Longer motor shafts are possible, please contact alpha

³⁾ The dimensions depend on the motor

⁴⁾ Smaller motor shaft diameter is compensated

by a bushing with a minimum thickness of 1 mm

⁵⁾ Standard clamping hub diameter

NPL 025 MF 1-stage

			1-stage							
Ratio	i		3	4	5	7	8	10		
Max. torque ^{a) b) e)}	T_{2a}	Nm	128	152	160	160	144	144		
		in.lb	1133	1345	1416	1416	1275	1275		
Max. acceleration torque ^{e)} (max. 1000 cycles per hour)	T_{2B}	Nm	80	95	100	100	90	90		
		in.lb	708	841	885	885	797	797		
Emergency stop torque ^{a) b) e)} (permitted 1000 times during the service life of the gearbox)	T_{2Not}	Nm	190	190	190	190	190	190		
		in.lb	1682	1682	1682	1682	1682	1682		
Permitted average input speed ^{d)} (at T_{2N} and 20 °C ambient temperature)	n_{1N}	rpm	2700	2900	3000	3200	3300	3500		
Max. input speed	n_{1Max}	rpm	7000	7000	7000	7000	7000	7000		
Mean no load running torque ^{b)} (at $n_1=3000$ rpm and 20 °C gearbox temperature)	T_{012}	Nm	1.8	1.5	1.3	1.1	1	0.94		
		in.lb	16	13	12	9.7	8.9	8.3		
Max. backlash	j_l	arcmin	≤ 8							
Torsional rigidity ^{b)}	C_{i21}	Nm/arcmin	9.5	9.5	9.5	9.5	8.5	8.5		
		in.lb/arcmin	84	84	84	84	75	75		
Max. axial force ^{c)}	F_{2AMax}	N	3350							
		lb _f	754							
Max. lateral force ^{c)}	F_{2QMMax}	N	4200							
		lb _f	945							
Max. tilting moment	M_{2KMMax}	Nm	236							
		in.lb	2089							
Efficiency at full load	η	%	97							
Service life	L_n	h	> 20000							
Weight (incl. standard adapter plate)	m	kg	3.9							
		lb _m	8.6							
Operating noise (at reference ratio and reference speed – ratio-specific values available in cymex [®])	L_{PA}	dB(A)	≤ 61							
Max. permitted housing temperature		°C	+90							
		°F	+194							
Ambient temperature		°C	-15 to +40							
		°F	+5 to +104							
Lubrication			Lubricated for life							
Direction of rotation			In- and output same direction							
Protection class			IP 65							
Elastomer coupling (recommended product type – validate sizing with cymex [®])			ELC-0060BA022.000-X							
Bore diameter of coupling on the application side		mm	X = 012.000 - 032.000							
Mass moment of inertia (relates to the drive) Clamping hub diameter [mm]	C	14	J_1	kgcm ²	0.58	0.47	0.38	0.3	0.28	0.26
				10 ⁻³ in.lb.s ²	0.51	0.42	0.34	0.27	0.25	0.23
	D	16	J_1	kgcm ²	0.73	0.62	0.53	0.43	0.42	0.4
				10 ⁻³ in.lb.s ²	0.65	0.55	0.47	0.38	0.37	0.35
	E	19	J_1	kgcm ²	0.81	0.71	0.61	0.53	0.51	0.49
				10 ⁻³ in.lb.s ²	0.72	0.63	0.54	0.47	0.45	0.43
	G	24	J_1	kgcm ²	1.8	1.7	1.6	1.6	1.5	1.5
				10 ⁻³ in.lb.s ²	1.6	1.5	1.4	1.4	1.3	1.3
	H	28	J_1	kgcm ²	1.6	1.4	1.4	1.3	1.3	1.2
				10 ⁻³ in.lb.s ²	1.4	1.2	1.2	1.2	1.2	1.1

Please use our sizing software cymex[®] for a detailed sizing – www.wittenstein-cymex.com

^{a)} Valid for torque transmission only

^{b)} Valid for standard clamping hub diameter

^{c)} Refers to center of the output shaft or flange

^{d)} Please reduce input speed at higher ambient temperatures

^{e)} Valid for: Smooth shaft

1-stage

up to 19⁴⁾ (E)⁵⁾
clamping hub diameter

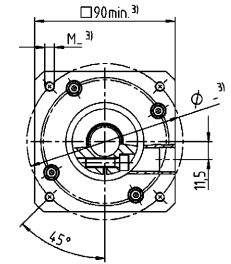
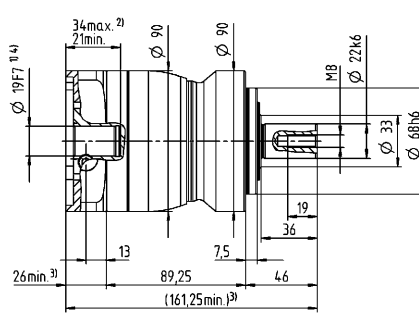
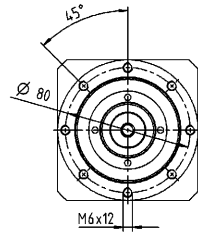

Motor shaft diameter [mm]

up to 28⁴⁾ (H)
clamping hub diameter

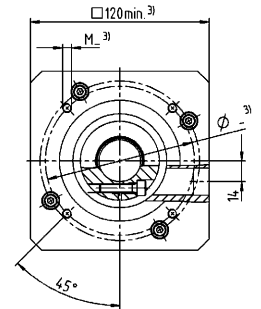
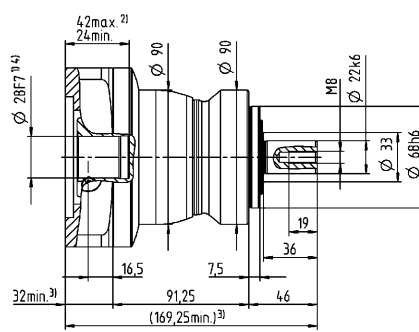
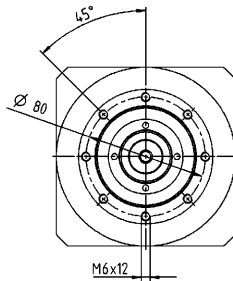

Planetary Gearboxes
Value Line

Other output variants

Shaft with key

Splined shaft (DIN 5480)

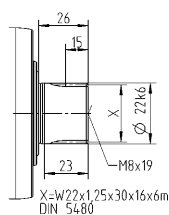
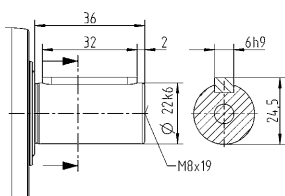

Non-tolerated dimensions are nominal dimensions

¹⁾ Check motor shaft fit

²⁾ Min. / Max. permissible motor shaft length

Longer motor shafts are possible, please contact alpha

³⁾ The dimensions depend on the motor

⁴⁾ Smaller motor shaft diameter is compensated

by a bushing with a minimum thickness of 1 mm

⁵⁾ Standard clamping hub diameter

NPL 025 MF 2-stage

			2-stage															
Ratio	i		9	12	15	16	20	25	28	30	32	35	40	50	64	70	100	
Max. torque ^{a) b) e)}	T_{2a}	Nm	128	128	128	152	152	160	152	128	144	160	152	160	144	160	144	
		in.lb	1133	1133	1133	1345	1345	1416	1345	1133	1275	1416	1345	1416	1275	1416	1275	
Max. acceleration torque ^{e)} (max. 1000 cycles per hour)	T_{2B}	Nm	80	80	80	95	95	100	95	80	90	100	95	100	90	100	90	
		in.lb	708	708	708	841	841	885	841	708	797	885	841	885	797	885	797	
Emergency stop torque ^{a) b) e)} (permitted 1000 times during the service life of the gearbox)	T_{2Not}	Nm	190	190	190	190	190	190	190	190	190	190	190	190	190	190	190	
		in.lb	1682	1682	1682	1682	1682	1682	1682	1682	1682	1682	1682	1682	1682	1682	1682	
Permitted average input speed ^{d)} (at T_{2N} and 20 °C ambient temperature)	n_{1N}	rpm	2900	3500	3700	3500	3700	3700	4000	4300	4100	4000	4300	4300	4100	4300	4300	
Max. input speed	n_{1Max}	rpm	8000	8000	8000	8000	8000	8000	8000	8000	8000	8000	8000	8000	8000	8000	8000	
Mean no load running torque ^{b)} (at $n_1=3000$ rpm and 20 °C gearbox temperature)	T_{012}	Nm	0.67	0.55	0.47	0.46	0.4	0.36	0.34	0.33	0.32	0.31	0.29	0.27	0.25	0.25	0.23	
		in.lb	5.9	4.9	4.2	4.1	3.5	3.2	3	2.9	2.8	2.7	2.6	2.4	2.2	2.2	2	
Max. backlash	j_l	arcmin	≤ 10															
Torsional rigidity ^{b)}	C_{121}	Nm/arcmin	10	10	10	10	10	9.5	10	10	10	9.5	10	9.5	8.5	9.5	8.5	
		in.lb/arcmin	89	89	89	89	89	84	89	89	89	84	89	84	75	84	75	
Max. axial force ^{c)}	F_{2AMax}	N	3350															
		lb _f	754															
Max. lateral force ^{c)}	F_{2QMMax}	N	4200															
		lb _f	945															
Max. tilting moment	M_{2KMMax}	Nm	236															
		in.lb	2089															
Efficiency at full load	η	%	95															
Service life	L_n	h	> 20000															
Weight (incl. standard adapter plate)	m	kg	4.2															
		lb _m	9.3															
Operating noise (at reference ratio and reference speed – ratio-specific values available in cymex [®])	L_{PA}	dB(A)	≤ 59															
Max. permitted housing temperature		°C	+90															
		°F	+194															
Ambient temperature		°C	-15 to +40															
		°F	+5 to +104															
Lubrication			Lubricated for life															
Direction of rotation			In- and output same direction															
Protection class			IP 65															
Elastomer coupling (recommended product type – validate sizing with cymex [®])			ELC-0060BA022.000-X															
Bore diameter of coupling on the application side		mm	X = 012.000 - 032.000															
Mass moment of inertia (relates to the drive) Clamping hub diameter [mm]	A	9	J_1	kgcm ²	0.26	0.22	0.21	0.21	0.2	0.2	0.19	0.19	0.19	0.19	0.19	0.19	0.19	0.19
				10 ⁻³ in.lb.s ²	0.23	0.19	0.19	0.19	0.18	0.18	0.17	0.17	0.17	0.17	0.17	0.17	0.17	0.17
	B	11	J_1	kgcm ²	0.28	0.24	0.23	0.23	0.22	0.22	0.21	0.21	0.21	0.21	0.21	0.21	0.21	0.21
				10 ⁻³ in.lb.s ²	0.25	0.21	0.2	0.2	0.19	0.19	0.19	0.19	0.19	0.19	0.19	0.19	0.19	0.19
	C	14	J_1	kgcm ²	0.35	0.31	0.3	0.3	0.3	0.29	0.29	0.28	0.28	0.28	0.28	0.28	0.28	0.28
				10 ⁻³ in.lb.s ²	0.31	0.27	0.27	0.27	0.27	0.26	0.26	0.25	0.25	0.25	0.25	0.25	0.25	0.25
	D	16	J_1	kgcm ²	0.48	0.44	0.43	0.43	0.42	0.42	0.41	0.41	0.41	0.41	0.41	0.41	0.41	0.41
				10 ⁻³ in.lb.s ²	0.42	0.39	0.38	0.38	0.37	0.37	0.36	0.36	0.36	0.36	0.36	0.36	0.36	0.36
	E	19	J_1	kgcm ²	0.56	0.52	0.51	0.52	0.51	0.5	0.5	0.5	0.5	0.5	0.49	0.49	0.49	0.49
				10 ⁻³ in.lb.s ²	0.5	0.46	0.45	0.46	0.45	0.44	0.44	0.44	0.44	0.44	0.43	0.43	0.43	0.43

Please use our sizing software cymex[®] for a detailed sizing – www.wittenstein-cymex.com

^{a)} Valid for torque transmission only

^{b)} Valid for standard clamping hub diameter

^{c)} Refers to center of the output shaft or flange

^{d)} Please reduce input speed at higher ambient temperatures

^{e)} Valid for: Smooth shaft

2-stage

Motor shaft diameter [mm]

up to 14⁴⁾ (C)⁵⁾
clamping hub diameter

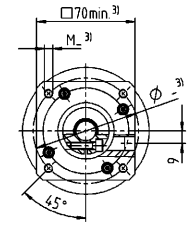
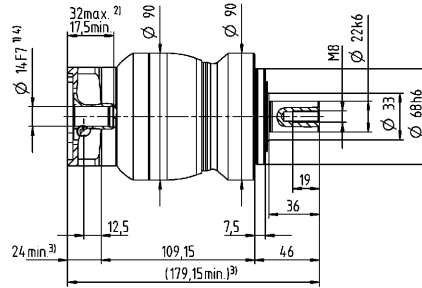
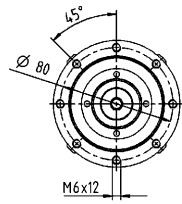

up to 19⁴⁾ (E)
clamping hub diameter

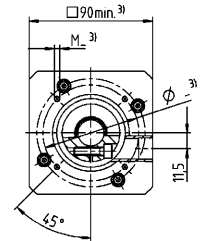
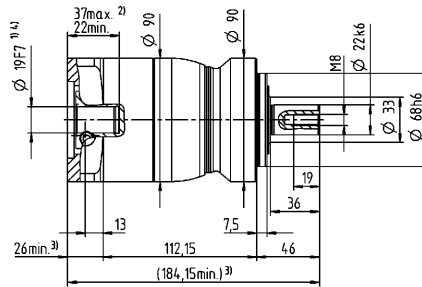
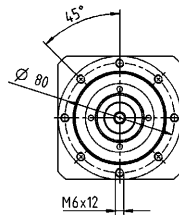

Planetary Gearboxes
Value Line

Other output variants

Shaft with key

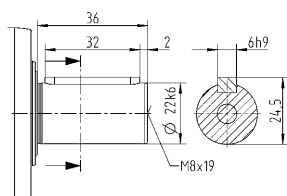

Splined shaft (DIN 5480)

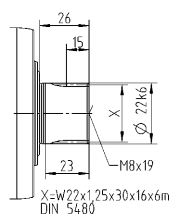

Non-tolerated dimensions are nominal dimensions

¹⁾ Check motor shaft fit

²⁾ Min. / Max. permissible motor shaft length

Longer motor shafts are possible, please contact alpha

³⁾ The dimensions depend on the motor

⁴⁾ Smaller motor shaft diameter is compensated

by a bushing with a minimum thickness of 1 mm

⁵⁾ Standard clamping hub diameter

NPL 035 MF 1-stage

			1-stage							
Ratio	i		3	4	5	7	8	10		
Max. torque ^{a) b) e)}	T_{2a}	Nm	320	408	400	400	352	352		
		in.lb	2832	3611	3540	3540	3115	3115		
Max. acceleration torque ^{e)} (max. 1000 cycles per hour)	T_{2B}	Nm	200	255	250	250	220	220		
		in.lb	1770	2257	2213	2213	1947	1947		
Emergency stop torque ^{a) b) e)} (permitted 1000 times during the service life of the gearbox)	T_{2Not}	Nm	500	500	500	500	500	500		
		in.lb	4425	4425	4425	4425	4425	4425		
Permitted average input speed ^{d)} (at T_{2a} and 20 °C ambient temperature)	n_{1N}	rpm	2000	2200	2300	2500	2600	2700		
Max. input speed	n_{1Max}	rpm	6000	6000	6000	6000	6000	6000		
Mean no load running torque ^{b)} (at $n_1=3000$ rpm and 20 °C gearbox temperature)	T_{012}	Nm	3.3	2.7	2.3	1.9	1.7	1.5		
		in.lb	29	24	20	17	15	13		
Max. backlash	j_l	arcmin	≤ 8							
Torsional rigidity ^{b)}	C_{t21}	Nm/arcmin	25	25	25	25	22	22		
		in.lb/arcmin	221	221	221	221	195	195		
Max. axial force ^{c)}	F_{2AMax}	N	5650							
		lb _f	1271							
Max. lateral force ^{c)}	F_{2QMMax}	N	6600							
		lb _f	1485							
Max. tilting moment	M_{2KMMax}	Nm	487							
		in.lb	4310							
Efficiency at full load	η	%	97							
Service life	L_n	h	> 20000							
Weight (incl. standard adapter plate)	m	kg	9.1							
		lb _m	20							
Operating noise (at reference ratio and reference speed – ratio-specific values available in cymex [®])	L_{PA}	dB(A)	≤ 65							
Max. permitted housing temperature		°C	+90							
		°F	+194							
Ambient temperature		°C	-15 to +40							
		°F	+5 to +104							
Lubrication			Lubricated for life							
Direction of rotation			In- and output same direction							
Protection class			IP 65							
Elastomer coupling (recommended product type – validate sizing with cymex [®])			ELC-0150BA032.000-X							
Bore diameter of coupling on the application side		mm	X = 019.000 - 036.000							
Mass moment of inertia (relates to the drive) Clamping hub diameter [mm]	E	19	J_1	kgcm ²	2.5	1.7	1.3	1	0.94	0.87
				10 ⁻³ in.lb.s ²	2.2	1.5	1.2	0.89	0.83	0.77
	G	24	J_1	kgcm ²	3.3	2.4	2.1	1.8	1.7	1.6
				10 ⁻³ in.lb.s ²	2.9	2.1	1.9	1.6	1.5	1.4
	H	28	J_1	kgcm ²	3	2.2	1.8	1.5	1.4	1.4
				10 ⁻³ in.lb.s ²	2.7	1.9	1.6	1.3	1.2	1.2
	I	32	J_1	kgcm ²	7.1	6.2	5.9	5.6	5.5	5.4
				10 ⁻³ in.lb.s ²	6.3	5.5	5.2	5	4.9	4.8
	K	38	J_1	kgcm ²	8.3	7.4	7.1	6.7	6.6	6.6
				10 ⁻³ in.lb.s ²	7.3	6.5	6.3	5.9	5.8	5.8

Please use our sizing software cymex[®] for a detailed sizing – www.wittenstein-cymex.com

^{a)} Valid for torque transmission only

^{b)} Valid for standard clamping hub diameter

^{c)} Refers to center of the output shaft or flange

^{d)} Please reduce input speed at higher ambient temperatures

^{e)} Valid for: Smooth shaft

1-stage

Motor shaft diameter [mm]

up to 24/28⁴⁾
(G⁵⁾/H)
clamping hub diameter

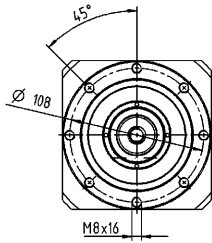

up to 38⁴⁾ (K)
clamping hub diameter

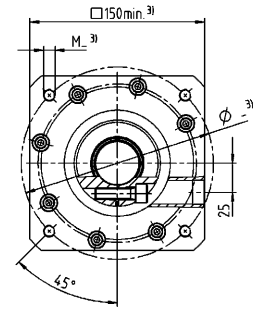
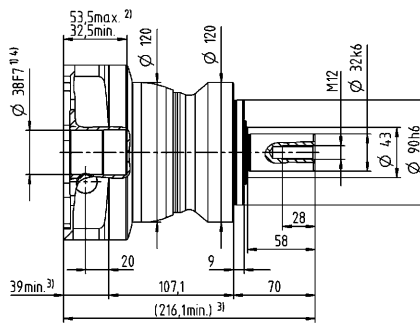
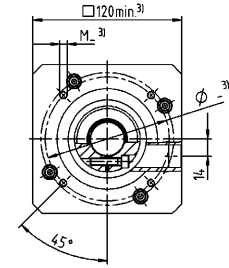
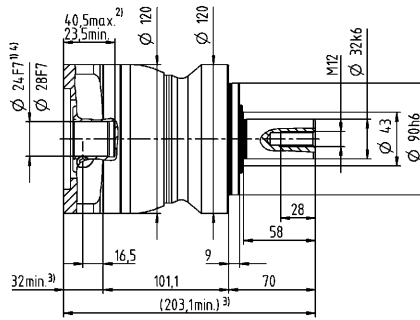
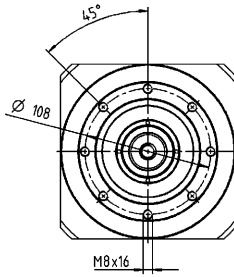

Other output variants

Shaft with key

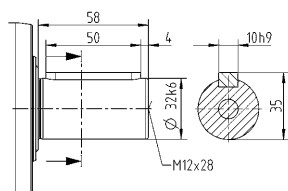

Splined shaft (DIN 5480)

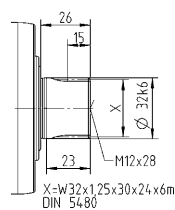

Non-tolerated dimensions are nominal dimensions

¹⁾ Check motor shaft fit

²⁾ Min. / Max. permissible motor shaft length

Longer motor shafts are possible, please contact alpha

³⁾ The dimensions depend on the motor

⁴⁾ Smaller motor shaft diameter is compensated

by a bushing with a minimum thickness of 1 mm

⁵⁾ Standard clamping hub diameter

NPL 035 MF 2-stage

			2-stage																
Ratio	i		9	12	15	16	20	25	28	30	32	35	40	50	64	70	100		
Max. torque ^{a) b) e)}	T_{2a}	Nm	320	320	320	408	408	400	408	320	408	400	408	400	352	400	352		
		in.lb	2832	2832	2832	3611	3611	3540	3611	2832	3611	3540	3611	3540	3115	3540	3115		
Max. acceleration torque ^{e)} (max. 1000 cycles per hour)	T_{2B}	Nm	200	200	200	255	255	250	255	200	255	250	255	250	220	250	220		
		in.lb	1770	1770	1770	2257	2257	2213	2257	1770	2257	2213	2257	2213	1947	2213	1947		
Emergency stop torque ^{a) b) e)} (permitted 1000 times during the service life of the gearbox)	T_{2Not}	Nm	500	500	500	500	500	500	500	500	500	500	500	500	500	500	500		
		in.lb	4425	4425	4425	4425	4425	4425	4425	4425	4425	4425	4425	4425	4425	4425	4425		
Permitted average input speed ^{d)} (at T_{2a} and 20 °C ambient temperature)	n_{1N}	rpm	2700	3300	3400	3300	3400	3400	3600	3900	3700	3600	3900	3900	3700	3900	3900		
Max. input speed	n_{1Max}	rpm	7000	7000	7000	7000	7000	7000	7000	7000	7000	7000	7000	7000	7000	7000	7000		
Mean no load running torque ^{b)} (at $n_1=3000$ rpm and 20 °C gearbox temperature)	T_{012}	Nm	1.7	1.4	1.2	1.2	1.1	1	0.93	0.88	0.88	0.87	0.81	0.77	0.75	0.72	0.68		
		in.lb	15	12	11	11	9.7	8.9	8.2	7.8	7.8	7.7	7.2	6.8	6.6	6.4	6		
Max. backlash	j_t	arcmin	≤ 10																
Torsional rigidity ^{b)}	C_{t21}	Nm/arcmin	25	25	25	25	25	25	25	25	25	25	25	25	22	25	22		
		in.lb/arcmin	221	221	221	221	221	221	221	221	221	221	221	221	195	221	195		
Max. axial force ^{c)}	F_{2AMax}	N	5650																
		lb _f	1271																
Max. lateral force ^{c)}	F_{2QMMax}	N	6600																
		lb _f	1485																
Max. tilting moment	M_{2KMMax}	Nm	487																
		in.lb	4310																
Efficiency at full load	η	%	95																
Service life	L_n	h	> 20000																
Weight (incl. standard adapter plate)	m	kg	9.5																
		lb _m	21																
Operating noise (at reference ratio and reference speed – ratio-specific values available in cymex®)	L_{PA}	dB(A)	≤ 61																
Max. permitted housing temperature		°C	+90																
		°F	+194																
Ambient temperature		°C	-15 to +40																
		°F	+5 to +104																
Lubrication			Lubricated for life																
Direction of rotation			In- and output same direction																
Protection class			IP 65																
Elastomer coupling (recommended product type – validate sizing with cymex®)			ELC-0150BA032.000-X																
Bore diameter of coupling on the application side		mm	X = 019.000 - 036.000																
Mass moment of inertia (relates to the drive) Clamping hub diameter [mm]	C	14	J_1	kgcm ²	0.6	0.59	0.6	0.43	0.42	0.36	0.37	0.52	0.38	0.32	0.36	0.31	0.26	0.27	0.24
				10 ⁻³ in.lb.s ²	0.53	0.52	0.53	0.38	0.37	0.32	0.33	0.46	0.34	0.28	0.32	0.27	0.23	0.24	0.21
	D	16	J_1	kgcm ²	0.75	0.74	0.74	0.58	0.57	0.5	0.5	0.67	0.52	0.45	0.51	0.46	0.4	0.41	0.39
				10 ⁻³ in.lb.s ²	0.66	0.65	0.65	0.51	0.5	0.44	0.44	0.59	0.46	0.4	0.45	0.41	0.35	0.36	0.35
	E	19	J_1	kgcm ²	0.84	0.83	0.83	0.66	0.65	0.59	0.6	0.75	0.61	0.55	0.6	0.54	0.49	0.5	0.48
				10 ⁻³ in.lb.s ²	0.74	0.73	0.73	0.58	0.58	0.52	0.53	0.66	0.54	0.49	0.53	0.48	0.43	0.44	0.42
	G	24	J_1	kgcm ²	1.9	1.9	1.9	1.7	1.7	1.6	1.6	1.8	1.6	1.6	1.6	1.6	1.5	1.5	1.5
				10 ⁻³ in.lb.s ²	1.7	1.6	1.7	1.5	1.5	1.4	1.5	1.6	1.5	1.4	1.4	1.4	1.3	1.4	1.3
	H	28	J_1	kgcm ²	1.6	1.6	1.6	1.4	1.4	1.3	1.3	1.5	1.4	1.3	1.3	1.3	1.2	1.2	1.2
				10 ⁻³ in.lb.s ²	1.4	1.4	1.4	1.2	1.2	1.2	1.2	1.3	1.2	1.1	1.2	1.1	1.1	1.1	1.1

Please use our sizing software cymex® for a detailed sizing – www.wittenstein-cymex.com

^{a)} Valid for torque transmission only

^{b)} Valid for standard clamping hub diameter

^{c)} Refers to center of the output shaft or flange

^{d)} Please reduce input speed at higher ambient temperatures

^{e)} Valid for: Smooth shaft

2-stage

Motor shaft diameter [mm]

up to 19⁴⁾ (E)⁵⁾
clamping hub diameter

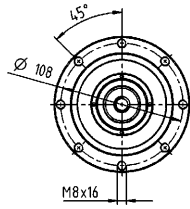

up to 28⁴⁾ (H)
clamping hub diameter

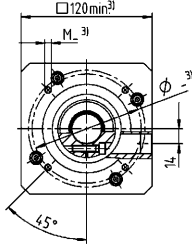
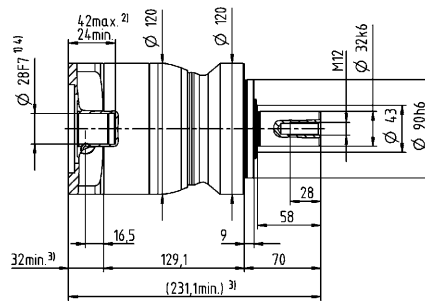
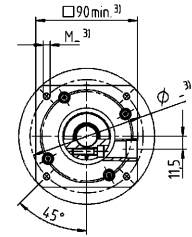
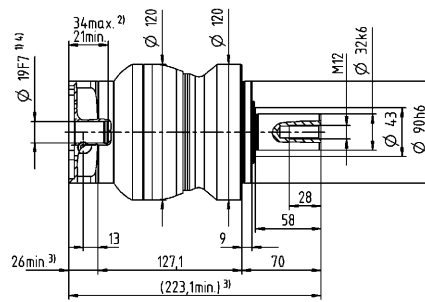
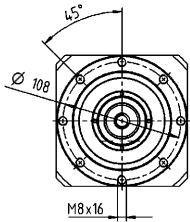

Planetary Gearboxes
Value Line

Other output variants

Shaft with key

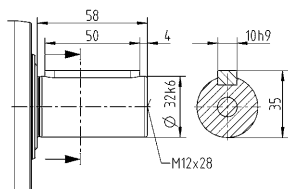

Splined shaft (DIN 5480)

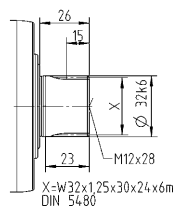

Non-tolerated dimensions are nominal dimensions

¹⁾ Check motor shaft fit

²⁾ Min. / Max. permissible motor shaft length

Longer motor shafts are possible, please contact alpha

³⁾ The dimensions depend on the motor

⁴⁾ Smaller motor shaft diameter is compensated

by a bushing with a minimum thickness of 1 mm

⁵⁾ Standard clamping hub diameter

NPL 045 MF 1-/2-stage

			1-stage			2-stage						
Ratio	i		5	8	10	25	32	50	64	100		
Max. torque ^{a) b) e)}	T_{2a}	Nm	800	640	640	700	640	700	640	640		
		in.lb	7081	5665	5665	6196	5665	6196	5665	5665		
Max. acceleration torque ^{e)} (max. 1000 cycles per hour)	T_{2B}	Nm	500	400	400	500	400	500	400	400		
		in.lb	4425	3540	3540	4425	3540	4425	3540	3540		
Emergency stop torque ^{a) b) e)} (permitted 1000 times during the service life of the gearbox)	T_{2Not}	Nm	1000	1000	1000	1000	1000	1000	1000	1000		
		in.lb	8851	8851	8851	8851	8851	8851	8851	8851		
Permitted average input speed ^{d)} (at T_{2a} and 20 °C ambient temperature)	n_{1N}	rpm	1800	1900	2000	2600	2500	3000	2900	3000		
Max. input speed	n_{1Max}	rpm	4000	4000	4000	6000	6000	6000	6000	6000		
Mean no load running torque ^{b)} (at $n_1=3000$ rpm and 20 °C gearbox temperature)	T_{012}	Nm	4.2	3	2.6	1.6	1.5	1.2	1.1	0.97		
		in.lb	37	27	23	14	13	11	9.7	8.6		
Max. backlash	j_l	arcmin	≤ 8			≤ 10						
Torsional rigidity ^{b)}	C_{i21}	Nm/arcmin	55	44	44	55	44	55	44	44		
		in.lb/arcmin	487	389	389	487	389	487	389	389		
Max. axial force ^{c)}	F_{2AMax}	N	9870			9870						
		lb _f	2221			2221						
Max. lateral force ^{c)}	F_{2QMax}	N	9900			9900						
		lb _f	2228			2228						
Max. tilting moment	M_{2KMMax}	Nm	952			952						
		in.lb	8426			8426						
Efficiency at full load	η	%	97			95						
Service life	L_n	h	> 20000			> 20000						
Weight (incl. standard adapter plate)	m	kg	20			20						
		lb _m	44			44						
Operating noise (at reference ratio and reference speed – ratio-specific values available in cymex [®])	L_{PA}	dB(A)	≤ 68			≤ 65						
Max. permitted housing temperature		°C	+90			+90						
		°F	+194			+194						
Ambient temperature		°C	-15 to +40			-15 to +40						
		°F	+5 to +104			+5 to +104						
Lubrication			Lubricated for life									
Direction of rotation			In- and output same direction									
Protection class			IP 65									
Elastomer coupling (recommended product type – validate sizing with cymex [®])			ELC-0300BA040.000-X									
Bore diameter of coupling on the application side		mm	X = 020.000 - 045.000									
Mass moment of inertia (relates to the drive) Clamping hub diameter [mm]	E	19	J_1	kgcm ²	-	-	-	1.2	1.1	1	0.88	0.82
				10 ⁻³ in.lb.s ²	-	-	-	1.1	0.97	0.89	0.78	0.73
	G	24	J_1	kgcm ²	-	-	-	2	1.9	1.8	1.7	1.6
				10 ⁻³ in.lb.s ²	-	-	-	1.8	1.7	1.6	1.5	1.4
	H	28	J_1	kgcm ²	-	-	-	1.7	1.6	1.5	1.4	1.3
				10 ⁻³ in.lb.s ²	-	-	-	1.5	1.4	1.3	1.2	1.2
	I	32	J_1	kgcm ²	-	-	-	5.8	5.7	5.6	5.4	5.4
				10 ⁻³ in.lb.s ²	-	-	-	5.1	5	5	4.8	4.8
	K	38	J_1	kgcm ²	8.7	7.3	7.2	7	6.9	6.8	6.6	6.5
				10 ⁻³ in.lb.s ²	7.7	6.5	6.4	6.2	6.1	6	5.8	5.8

Please use our sizing software cymex[®] for a detailed sizing – www.wittenstein-cymex.com

^{a)} Valid for torque transmission only

^{b)} Valid for standard clamping hub diameter

^{c)} Refers to center of the output shaft or flange

^{d)} Please reduce input speed at higher ambient temperatures

^{e)} Valid for: Smooth shaft

1-stage

up to 38⁴⁾ (K)⁵⁾
clamping hub
diameter

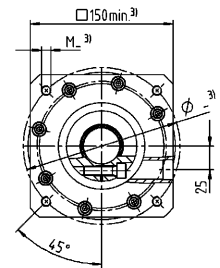
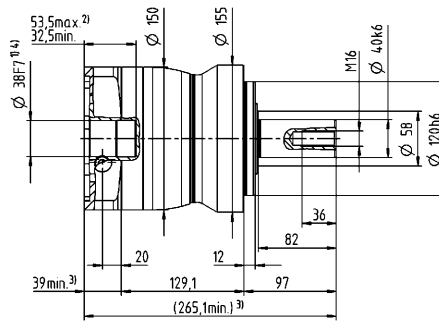
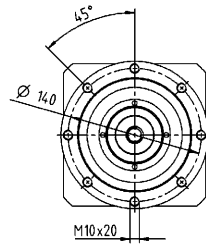

2-stage

up to 28⁴⁾ (H)⁵⁾
clamping hub
diameter

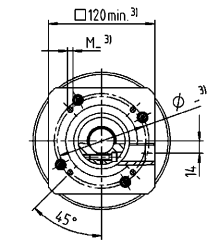
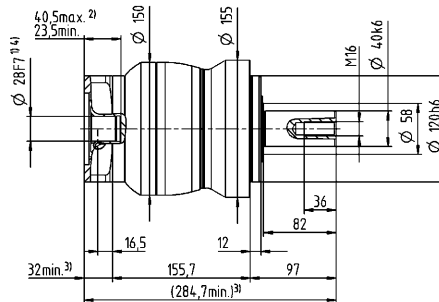
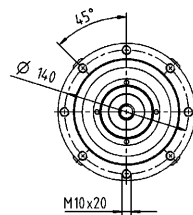

Motor shaft diameter [mm]

up to 38⁴⁾ (K)
clamping hub
diameter

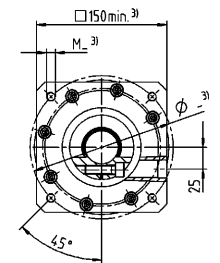
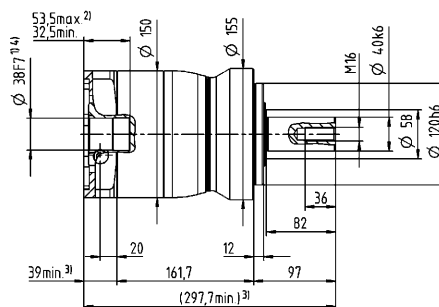
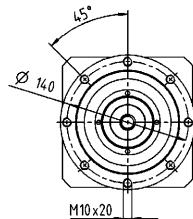

Planetary Gearboxes
Value Line

Other output variants

Shaft with key

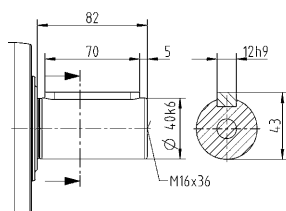

Splined shaft (DIN 5480)

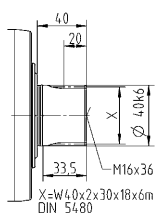

Non-tolerated dimensions are nominal dimensions

¹⁾ Check motor shaft fit

²⁾ Min. / Max. permissible motor shaft length

Longer motor shafts are possible, please contact alpha

³⁾ The dimensions depend on the motor

⁴⁾ Smaller motor shaft diameter is compensated

by a bushing with a minimum thickness of 1 mm

⁵⁾ Standard clamping hub diameter

NPL 015 MA 1-/2-stage

			1-stage		2-stage							
Ratio	i		3	4	12	15	16	20	28	30	40	
Max. torque ^{a) b) e)}	T_{2a}	Nm	80	67	62	67	67	67	67	62	67	
		in.lb	708	593	549	593	593	593	593	593	549	593
Max. acceleration torque ^{e)} (max. 1000 cycles per hour)	T_{2B}	Nm	55	42	39	42	42	42	42	39	42	
		in.lb	487	372	345	372	372	372	372	372	345	372
Emergency stop torque ^{a) b) e)} (permitted 1000 times during the service life of the gearbox)	T_{2Not}	Nm	80	80	80	80	80	80	80	80	80	
		in.lb	708	708	708	708	708	708	708	708	708	708
Permitted average input speed ^{d)} (at T_{2N} and 20 °C ambient temperature)	n_{1N}	rpm	2900	3100	3800	4000	3800	4000	4300	4600	4600	
Max. input speed	n_{1Max}	rpm	8000	8000	10000	10000	10000	10000	10000	10000	10000	
Mean no load running torque ^{b)} (at $n_1=3000$ rpm and 20 °C gearbox temperature)	T_{012}	Nm	0.92	0.74	0.34	0.29	0.29	0.25	0.21	0.21	0.19	
		in.lb	8.1	6.5	3	2.6	2.6	2.2	1.9	1.9	1.7	
Max. backlash	j_l	arcmin	≤ 8		≤ 10							
Torsional rigidity ^{b)}	C_{121}	Nm/arcmin	4	4	4	4	4	4	4	4	4	
		in.lb/arcmin	35	35	35	35	35	35	35	35	35	
Max. axial force ^{c)}	F_{2AMax}	N	2400		2400							
		lb _f	540		540							
Max. lateral force ^{c)}	F_{2QMMax}	N	2800		2800							
		lb _f	630		630							
Max. tilting moment	M_{2KMMax}	Nm	152		152							
		in.lb	1345		1345							
Efficiency at full load	η	%	97		95							
Service life	L_n	h	> 20000		> 20000							
Weight (incl. standard adapter plate)	m	kg	1.9		2							
		lb _m	4.2		4.4							
Operating noise (at reference ratio and reference speed – ratio-specific values available in cymex [®])	L_{PA}	dB(A)	≤ 59		≤ 58							
Max. permitted housing temperature		°C	+90		+90							
		°F	+194		+194							
Ambient temperature		°C	-15 to +40		-15 to +40							
		°F	+5 to +104		+5 to +104							
Lubrication			Lubricated for life									
Direction of rotation			In- and output same direction									
Protection class			IP 65									
Elastomer coupling (recommended product type – validate sizing with cymex [®])			ELC-0060BA016.000-X									
Bore diameter of coupling on the application side		mm	X = 012.000 - 032.000									
Mass moment of inertia (relates to the drive) Clamping hub diameter [mm]	Z	8	J_1	kgcm ²	-	-	0.04	0.04	0.03	0.03	0.03	0.03
				10 ⁻³ in.lb.s ²	-	-	0.04	0.04	0.03	0.03	0.03	0.03
	A	9	J_1	kgcm ²	0.25	0.19	0.04	0.04	0.03	0.03	0.03	0.03
				10 ⁻³ in.lb.s ²	0.22	0.17	0.04	0.04	0.03	0.03	0.03	0.03
	B	11	J_1	kgcm ²	0.26	0.21	0.06	0.06	0.05	0.05	0.05	0.05
				10 ⁻³ in.lb.s ²	0.23	0.19	0.05	0.05	0.04	0.04	0.04	0.04
	C	14	J_1	kgcm ²	0.34	0.28	0.14	0.14	0.14	0.13	0.13	0.14
				10 ⁻³ in.lb.s ²	0.3	0.25	0.12	0.12	0.12	0.12	0.12	0.12
	D	16	J_1	kgcm ²	0.47	0.41	-	-	-	-	-	-
				10 ⁻³ in.lb.s ²	0.42	0.36	-	-	-	-	-	-
	E	19	J_1	kgcm ²	0.55	0.49	-	-	-	-	-	-
				10 ⁻³ in.lb.s ²	0.49	0.43	-	-	-	-	-	-

Please use our sizing software cymex[®] for a detailed sizing – www.wittenstein-cymex.com

^{a)} Valid for torque transmission only

^{b)} Valid for standard clamping hub diameter

^{c)} Refers to center of the output shaft or flange

^{d)} Please reduce input speed at higher ambient temperatures

^{e)} Valid for: Smooth shaft

1-stage

up to 14⁴⁾ (C)⁵⁾
clamping hub diameter

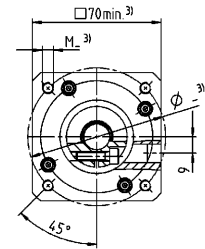
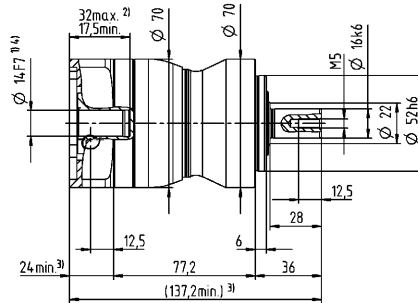
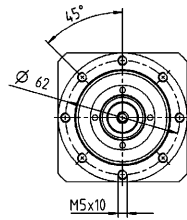

up to 19⁴⁾ (E)
clamping hub diameter

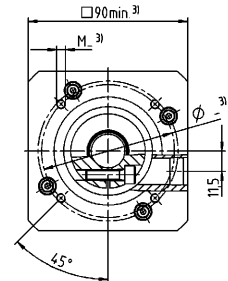
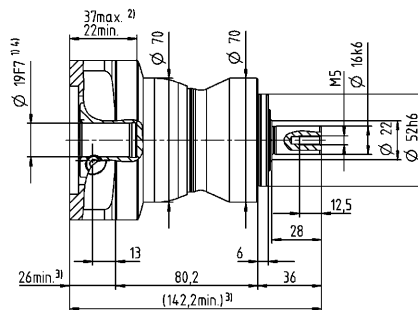
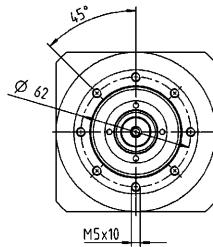

2-stage

up to 11⁴⁾ (B)⁵⁾
clamping hub diameter

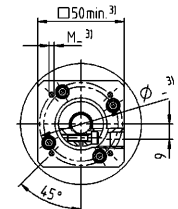
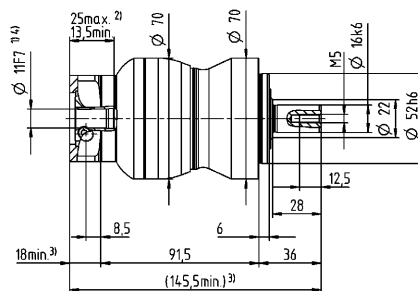
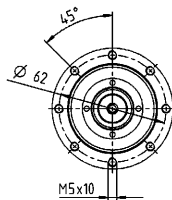

up to 14⁴⁾ (C)
clamping hub diameter

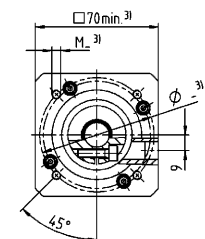
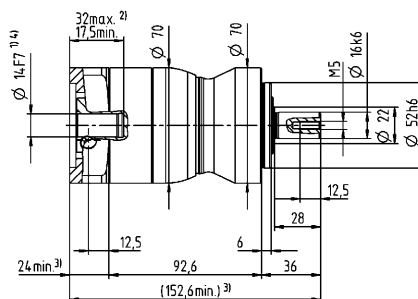
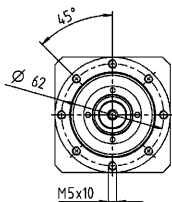

Motor shaft diameter [mm]

Other output variants

Shaft with key

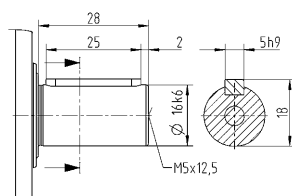

Splined shaft (DIN 5480)

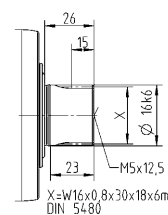

Non-tolerated dimensions are nominal dimensions

¹⁾ Check motor shaft fit

²⁾ Min. / Max. permissible motor shaft length

Longer motor shafts are possible, please contact alpha

³⁾ The dimensions depend on the motor

⁴⁾ Smaller motor shaft diameter is compensated

by a bushing with a minimum thickness of 1 mm

⁵⁾ Standard clamping hub diameter

NPL 025 MA 1-/2-stage

			1-stage		2-stage									
Ratio	i		3	4	9	12	15	16	20	28	30	40		
Max. torque ^{a) b) e)}	T_{2a}	Nm	185	185	185	185	185	185	185	185	168	185		
		in.lb	1637	1637	1637	1637	1637	1637	1637	1637	1637	1487	1637	
Max. acceleration torque ^{e)} (max. 1000 cycles per hour)	T_{2B}	Nm	125	115	125	125	120	115	115	115	105	115		
		in.lb	1106	1018	1106	1106	1062	1018	1018	1018	929	1018		
Emergency stop torque ^{a) b) e)} (permitted 1000 times during the service life of the gearbox)	T_{2Not}	Nm	190	190	190	190	190	190	190	190	190	190		
		in.lb	1682	1682	1682	1682	1682	1682	1682	1682	1682	1682		
Permitted average input speed ^{d)} (at T_{2N} and 20 °C ambient temperature)	n_{1N}	rpm	2700	2900	2900	3500	3700	3500	3700	4000	4300	4300		
Max. input speed	n_{1Max}	rpm	7000	7000	8000	8000	8000	8000	8000	8000	8000	8000		
Mean no load running torque ^{b)} (at $n_1=3000$ rpm and 20 °C gearbox temperature)	T_{012}	Nm	1.8	1.5	0.67	0.55	0.47	0.46	0.4	0.34	0.33	0.29		
		in.lb	16	13	5.9	4.9	4.2	4.1	3.5	3	2.9	2.6		
Max. backlash	j_l	arcmin	≤ 8		≤ 10									
Torsional rigidity ^{b)}	C_{i21}	Nm/arcmin	12	12	12	12	12	12	12	12	12	12		
		in.lb/arcmin	106	106	106	106	106	106	106	106	106	106		
Max. axial force ^{c)}	F_{2AMax}	N	3350		3350									
		lb _f	754		754									
Max. lateral force ^{c)}	F_{2QMMax}	N	4200		4200									
		lb _f	945		945									
Max. tilting moment	M_{2KMMax}	Nm	236		236									
		in.lb	2089		2089									
Efficiency at full load	η	%	97		95									
Service life	L_n	h	> 20000		> 20000									
Weight (incl. standard adapter plate)	m	kg	3.9		4.2									
		lb _m	8.6		9.3									
Operating noise (at reference ratio and reference speed – ratio-specific values available in cymex®)	L_{PA}	dB(A)	≤ 61		≤ 59									
			°C		+90		+90							
Max. permitted housing temperature			°F		+194		+194							
			°C		-15 to +40		-15 to +40							
Ambient temperature			°F		+5 to +104		+5 to +104							
			Lubricated for life											
Direction of rotation		In- and output same direction												
Protection class		IP 65												
Elastomer coupling (recommended product type – validate sizing with cymex®)		ELC-0060BA022.000-X												
Bore diameter of coupling on the application side		mm	X = 012.000 - 032.000											
Mass moment of inertia (relates to the drive) Clamping hub diameter [mm]	A	9	J_1	kgcm ²	-	-	0.26	0.22	0.21	0.21	0.2	0.19	0.19	
				10 ⁻³ in.lb.s ²	-	-	0.23	0.19	0.19	0.19	0.18	0.17	0.17	
	B	11	J_1	kgcm ²	-	-	0.28	0.24	0.23	0.23	0.22	0.21	0.21	
				10 ⁻³ in.lb.s ²	-	-	0.25	0.21	0.2	0.2	0.19	0.19	0.19	
	C	14	J_1	kgcm ²	0.58	0.47	0.35	0.31	0.3	0.3	0.3	0.29	0.28	
				10 ⁻³ in.lb.s ²	0.51	0.42	0.31	0.27	0.27	0.27	0.27	0.26	0.25	
	D	16	J_1	kgcm ²	0.73	0.62	0.48	0.44	0.43	0.43	0.42	0.41	0.41	
				10 ⁻³ in.lb.s ²	0.65	0.55	0.42	0.39	0.38	0.38	0.37	0.36	0.36	
	E	19	J_1	kgcm ²	0.81	0.71	0.56	0.52	0.51	0.52	0.51	0.5	0.5	
				10 ⁻³ in.lb.s ²	0.72	0.63	0.5	0.46	0.45	0.46	0.45	0.44	0.44	
	G	24	J_1	kgcm ²	1.8	1.7	-	-	-	-	-	-	-	
				10 ⁻³ in.lb.s ²	1.6	1.5	-	-	-	-	-	-	-	
	H	28	J_1	kgcm ²	1.6	1.4	-	-	-	-	-	-	-	
				10 ⁻³ in.lb.s ²	1.4	1.2	-	-	-	-	-	-	-	

Please use our sizing software cymex® for a detailed sizing – www.wittenstein-cymex.com

^{a)} Valid for torque transmission only

^{b)} Valid for standard clamping hub diameter

^{c)} Refers to center of the output shaft or flange

^{d)} Please reduce input speed at higher ambient temperatures

^{e)} Valid for: Smooth shaft

1-stage

up to 19⁴⁾ (E)⁵⁾
clamping hub diameter

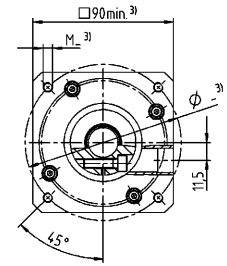
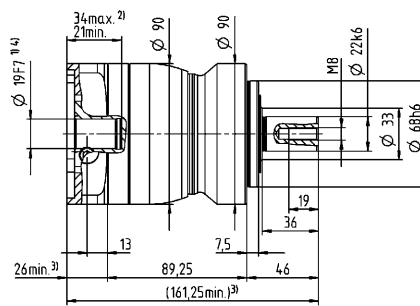
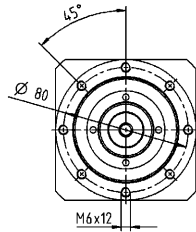

up to 28⁴⁾ (H)
clamping hub diameter

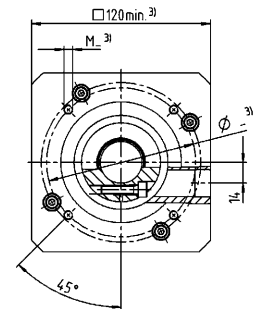
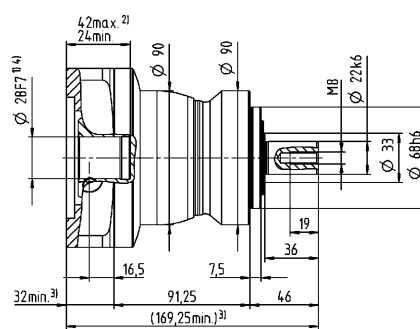
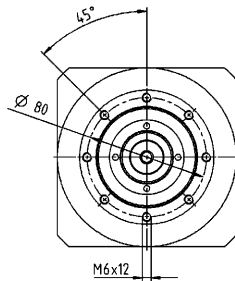

2-stage

up to 14⁴⁾ (C)⁵⁾
clamping hub diameter

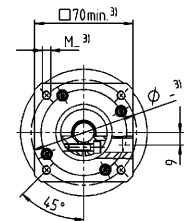
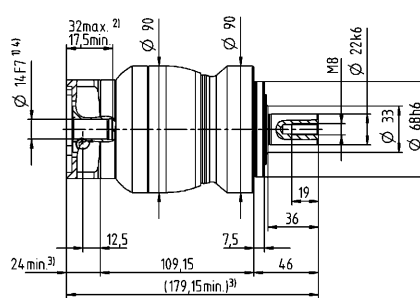
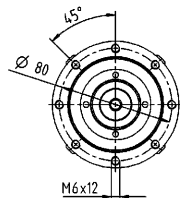

up to 19⁴⁾ (E)
clamping hub diameter

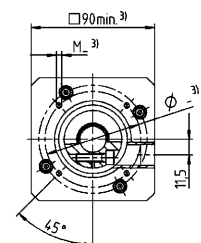
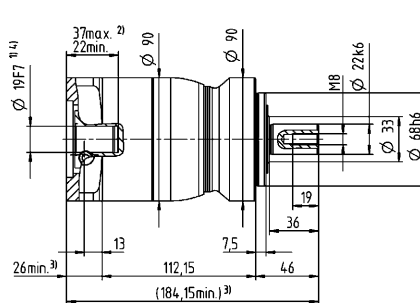
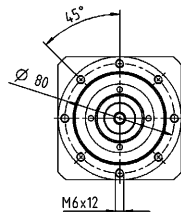

Motor shaft diameter [mm]

Other output variants

Shaft with key

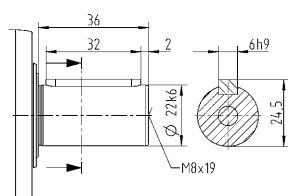

Splined shaft (DIN 5480)

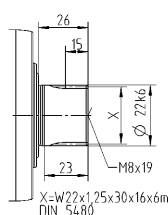

Non-tolerated dimensions are nominal dimensions

¹⁾ Check motor shaft fit

²⁾ Min. / Max. permissible motor shaft length

Longer motor shafts are possible, please contact alpha

³⁾ The dimensions depend on the motor

⁴⁾ Smaller motor shaft diameter is compensated

by a bushing with a minimum thickness of 1 mm

⁵⁾ Standard clamping hub diameter

NPL 035 MA 1-/2-stage

			1-stage		2-stage									
Ratio	i		3	4	9	12	15	16	20	28	30	40		
Max. torque ^{a) b) e)}	T_{2a}	Nm	480	480	480	480	480	480	480	480	432	480		
		in.lb	4248	4248	4248	4248	4248	4248	4248	4248	4248	3824	4248	
Max. acceleration torque ^{e)} (max. 1000 cycles per hour)	T_{2B}	Nm	305	305	305	305	300	305	305	305	270	305		
		in.lb	2699	2699	2699	2699	2655	2699	2699	2699	2390	2699		
Emergency stop torque ^{a) b) e)} (permitted 1000 times during the service life of the gearbox)	T_{2Not}	Nm	500	500	500	500	500	500	500	500	500	500		
		in.lb	4425	4425	4425	4425	4425	4425	4425	4425	4425	4425		
Permitted average input speed ^{d)} (at T_{2N} and 20 °C ambient temperature)	n_{1N}	rpm	2000	2200	2700	3300	3400	3300	3400	3600	3900	3900		
Max. input speed	n_{1Max}	rpm	6000	6000	7000	7000	7000	7000	7000	7000	7000	7000		
Mean no load running torque ^{b)} (at $n_1=3000$ rpm and 20 °C gearbox temperature)	T_{012}	Nm	3.3	2.7	1.7	1.4	1.2	1.2	1.1	0.93	0.88	0.81		
		in.lb	29	24	15	12	11	11	9.7	8.2	7.8	7.2		
Max. backlash	j_l	arcmin	≤ 8		≤ 10									
Torsional rigidity ^{b)}	C_{i21}	Nm/arcmin	30	30	30	30	30	30	30	30	30	30		
		in.lb/arcmin	266	266	266	266	266	266	266	266	266	266		
Max. axial force ^{c)}	F_{2AMax}	N	5650		5650									
		lb _f	1271		1271									
Max. lateral force ^{c)}	F_{2QMMax}	N	6600		6600									
		lb _f	1485		1485									
Max. tilting moment	M_{2KMMax}	Nm	487		487									
		in.lb	4310		4310									
Efficiency at full load	η	%	97		95									
Service life	L_n	h	> 20000		> 20000									
Weight (incl. standard adapter plate)	m	kg	9.1		9.5									
		lb _m	20		21									
Operating noise (at reference ratio and reference speed – ratio-specific values available in cymex®)	L_{PA}	dB(A)	≤ 65		≤ 61									
		°C	+90		+90									
Max. permitted housing temperature		°F	+194		+194									
		°C	-15 to +40		-15 to +40									
Ambient temperature		°F	+5 to +104		+5 to +104									
			Lubricated for life											
Direction of rotation			In- and output same direction											
Protection class			IP 65											
Elastomer coupling (recommended product type – validate sizing with cymex®)			ELC-0150BA032.000-X											
Bore diameter of coupling on the application side		mm	X = 019.000 - 036.000											
Mass moment of inertia (relates to the drive) Clamping hub diameter [mm]	C	14	J_1	kgcm ²	-	-	0.6	0.59	0.6	0.43	0.42	0.37	0.52	0.36
				10 ⁻³ in.lb.s ²	-	-	0.53	0.52	0.53	0.38	0.37	0.33	0.46	0.32
	D	16	J_1	kgcm ²	-	-	0.75	0.74	0.74	0.58	0.57	0.5	0.67	0.51
				10 ⁻³ in.lb.s ²	-	-	0.66	0.65	0.65	0.51	0.5	0.44	0.59	0.45
	E	19	J_1	kgcm ²	2.5	1.7	0.84	0.83	0.83	0.66	0.65	0.6	0.75	0.6
				10 ⁻³ in.lb.s ²	2.2	1.5	0.74	0.73	0.73	0.58	0.58	0.53	0.66	0.53
	G	24	J_1	kgcm ²	3.3	2.4	1.9	1.9	1.9	1.7	1.7	1.6	1.8	1.6
				10 ⁻³ in.lb.s ²	2.9	2.1	1.7	1.6	1.7	1.5	1.5	1.5	1.6	1.4
	H	28	J_1	kgcm ²	3	2.2	1.6	1.6	1.6	1.4	1.4	1.3	1.5	1.3
				10 ⁻³ in.lb.s ²	2.7	1.9	1.4	1.4	1.4	1.2	1.2	1.2	1.3	1.2
	I	32	J_1	kgcm ²	7.1	6.2	-	-	-	-	-	-	-	-
				10 ⁻³ in.lb.s ²	6.3	5.5	-	-	-	-	-	-	-	-
	K	38	J_1	kgcm ²	8.3	7.4	-	-	-	-	-	-	-	-
				10 ⁻³ in.lb.s ²	7.3	6.5	-	-	-	-	-	-	-	-

Please use our sizing software cymex® for a detailed sizing – www.wittenstein-cymex.com

^{a)} Valid for torque transmission only

^{b)} Valid for standard clamping hub diameter

^{c)} Refers to center of the output shaft or flange

^{d)} Please reduce input speed at higher ambient temperatures

^{e)} Valid for: Smooth shaft

1-stage

up to 24/28⁴⁾
(G⁵⁾/H)
clamping hub
diameter

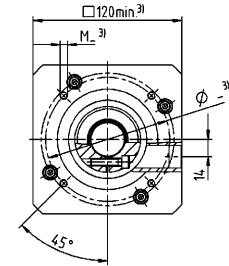
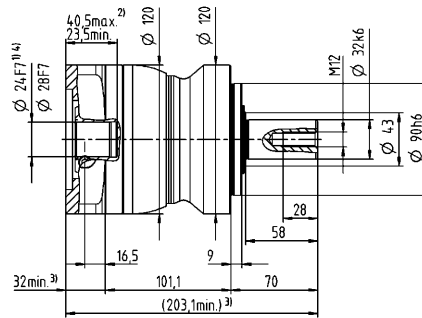
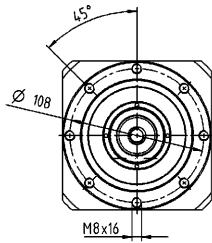

up to 38⁴⁾ (K)
clamping hub
diameter

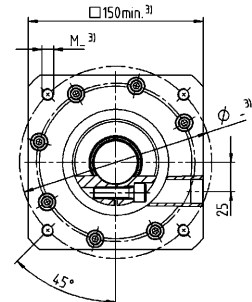
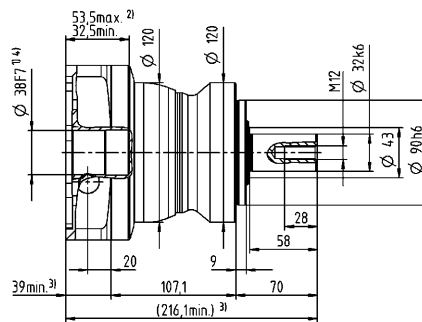
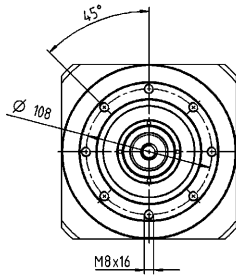

2-stage

up to 19⁴⁾ (E)⁵⁾
clamping hub
diameter

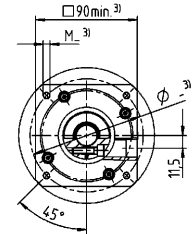
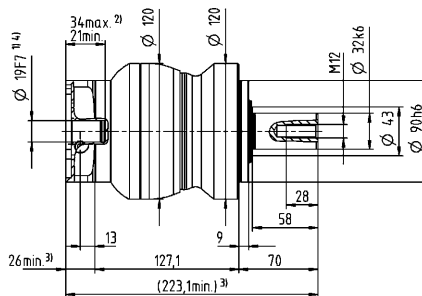
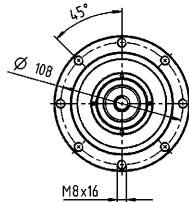

up to 28⁴⁾ (H)
clamping hub
diameter

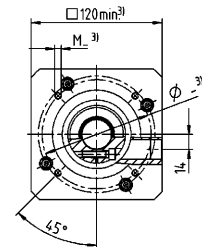
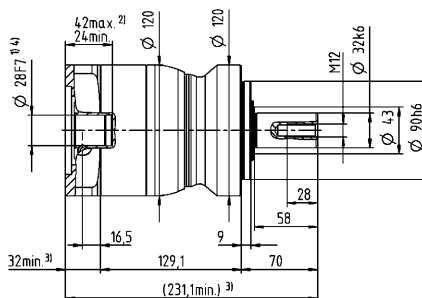
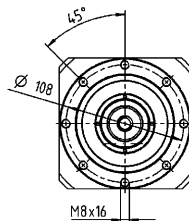

Motor shaft diameter [mm]

Other output variants

Shaft with key

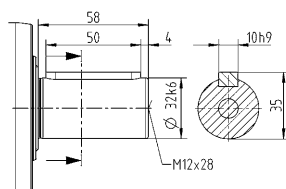

Splined shaft (DIN 5480)

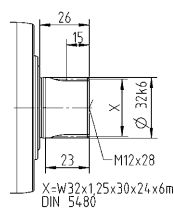

Non-tolerated dimensions are nominal dimensions

¹⁾ Check motor shaft fit

²⁾ Min. / Max. permissible motor shaft length

Longer motor shafts are possible, please contact alpha

³⁾ The dimensions depend on the motor

⁴⁾ Smaller motor shaft diameter is compensated

by a bushing with a minimum thickness of 1 mm

⁵⁾ Standard clamping hub diameter

NPS 015 MF 1-stage

			1-stage							
Ratio	i		3	4	5	7	8	10		
Max. torque ^{a) b) e)}	T_{2a}	Nm	51	56	64	64	56	56		
		in.lb	451	496	566	566	496	496		
Max. acceleration torque ^{e)} (max. 1000 cycles per hour)	T_{2B}	Nm	32	35	40	40	35	35		
		in.lb	283	310	354	354	310	310		
Emergency stop torque ^{a) b) e)} (permitted 1000 times during the service life of the gearbox)	T_{2Not}	Nm	80	80	80	80	80	80		
		in.lb	708	708	708	708	708	708		
Permitted average input speed ^{d)} (at T_{2N} and 20 °C ambient temperature)	n_{1N}	rpm	2900	3100	3300	3600	3600	3800		
Max. input speed	n_{1Max}	rpm	8000	8000	8000	8000	8000	8000		
Mean no load running torque ^{b)} (at $n_1=3000$ rpm and 20 °C gearbox temperature)	T_{012}	Nm	0.92	0.74	0.62	0.51	0.47	0.41		
		in.lb	8.1	6.5	5.5	4.5	4.2	3.6		
Max. backlash	j_l	arcmin	≤ 8							
Torsional rigidity ^{b)}	C_{121}	Nm/arcmin	3.3	3.3	3.3	3.3	2.8	2.8		
		in.lb/arcmin	29	29	29	29	25	25		
Max. axial force ^{c)}	F_{2AMax}	N	2400							
		lb _f	540							
Max. lateral force ^{c)}	F_{2QMMax}	N	2800							
		lb _f	630							
Max. tilting moment	M_{2KMMax}	Nm	152							
		in.lb	1345							
Efficiency at full load	η	%	97							
Service life	L_n	h	> 20000							
Weight (incl. standard adapter plate)	m	kg	1.8							
		lb _m	4							
Operating noise (at reference ratio and reference speed – ratio-specific values available in cymex [®])	L_{PA}	dB(A)	≤ 59							
Max. permitted housing temperature		°C	+90							
		°F	+194							
Ambient temperature		°C	-15 to +40							
		°F	+5 to +104							
Lubrication			Lubricated for life							
Direction of rotation			In- and output same direction							
Protection class			IP 65							
Elastomer coupling (recommended product type – validate sizing with cymex [®])			ELC-0060BA016.000-X							
Bore diameter of coupling on the application side		mm	X = 012.000 - 032.000							
Mass moment of inertia (relates to the drive) Clamping hub diameter [mm]	A	9	J_1	kgcm ²	0.25	0.19	0.17	0.14	0.14	0.13
				10 ⁻³ in.lb.s ²	0.22	0.17	0.15	0.12	0.12	0.12
	B	11	J_1	kgcm ²	0.26	0.21	0.18	0.16	0.16	0.15
				10 ⁻³ in.lb.s ²	0.23	0.19	0.16	0.14	0.14	0.13
	C	14	J_1	kgcm ²	0.34	0.28	0.26	0.24	0.23	0.23
				10 ⁻³ in.lb.s ²	0.3	0.25	0.23	0.21	0.2	0.2
	D	16	J_1	kgcm ²	0.47	0.41	0.39	0.36	0.36	0.35
				10 ⁻³ in.lb.s ²	0.42	0.36	0.35	0.32	0.32	0.31
	E	19	J_1	kgcm ²	0.55	0.49	0.47	0.45	0.44	0.44
				10 ⁻³ in.lb.s ²	0.49	0.43	0.42	0.4	0.39	0.39

Please use our sizing software cymex[®] for a detailed sizing – www.wittenstein-cymex.com

^{a)} Valid for torque transmission only

^{b)} Valid for standard clamping hub diameter

^{c)} Refers to center of the output shaft or flange

^{d)} Please reduce input speed at higher ambient temperatures

^{e)} Valid for: Smooth shaft

1-stage

up to 14⁴⁾ (C)⁵⁾
clamping hub
diameter

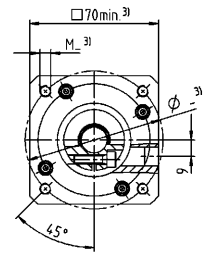
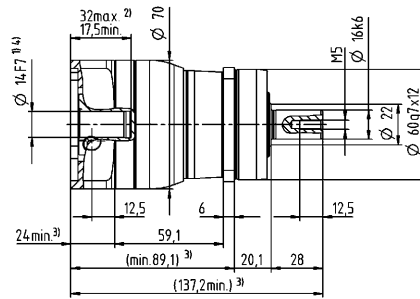
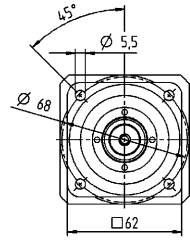

Motor shaft diameter [mm]

up to 19⁴⁾ (E)
clamping hub
diameter

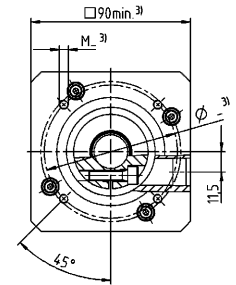
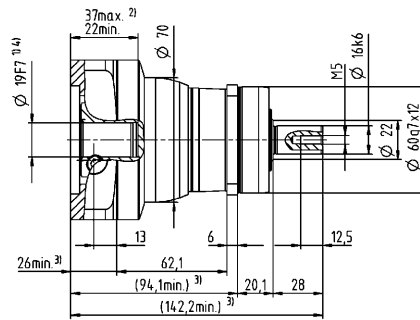
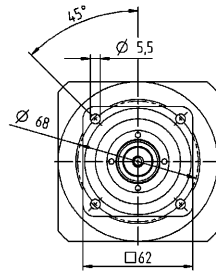

Planetary Gearboxes
Value Line

Other output variants

Shaft with key

Splined shaft (DIN 5480)

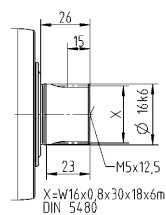
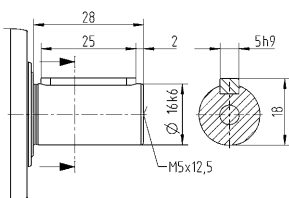

Non-tolerated dimensions are nominal dimensions

¹⁾ Check motor shaft fit

²⁾ Min. / Max. permissible motor shaft length

Longer motor shafts are possible, please contact alpha

³⁾ The dimensions depend on the motor

⁴⁾ Smaller motor shaft diameter is compensated

by a bushing with a minimum thickness of 1 mm

⁵⁾ Standard clamping hub diameter

NPS 015 MF 2-stage

			2-stage														
Ratio	i		12	15	16	20	25	28	30	32	35	40	50	64	70	100	
Max. torque ^{a) b) e)}	T_{2a}	Nm	51	51	56	56	64	56	51	56	64	56	64	56	64	56	
		in.lb	451	451	496	496	566	496	451	496	566	496	566	496	566	496	566
Max. acceleration torque ^{e)} (max. 1000 cycles per hour)	T_{2B}	Nm	32	32	35	35	40	35	32	35	40	35	40	35	40	35	
		in.lb	283	283	310	310	354	310	283	310	354	310	354	310	354	310	
Emergency stop torque ^{a) b) e)} (permitted 1000 times during the service life of the gearbox)	T_{2Not}	Nm	80	80	80	80	80	80	80	80	80	80	80	80	80	80	
		in.lb	708	708	708	708	708	708	708	708	708	708	708	708	708	708	
Permitted average input speed ^{d)} (at T_{2N} and 20 °C ambient temperature)	n_{1N}	rpm	3800	4000	3800	4000	4000	4300	4600	4400	4300	4600	4600	4400	4600	4600	
Max. input speed	n_{1Max}	rpm	10000	10000	10000	10000	10000	10000	10000	10000	10000	10000	10000	10000	10000	10000	
Mean no load running torque ^{b)} (at $n_1=3000$ rpm and 20 °C gearbox temperature)	T_{012}	Nm	0.34	0.29	0.29	0.25	0.23	0.21	0.21	0.2	0.2	0.19	0.17	0.17	0.16	0.15	
		in.lb	3	2.6	2.6	2.2	2	1.9	1.9	1.8	1.8	1.7	1.5	1.5	1.4	1.3	
Max. backlash	j_l	arcmin	≤ 10														
Torsional rigidity ^{b)}	C_{121}	Nm/arcmin	3.3	3.3	3.3	3.3	3.3	3.3	3.3	3.3	3.3	3.3	3.3	2.8	3.3	2.8	
		in.lb/arcmin	29	29	29	29	29	29	29	29	29	29	29	29	25	29	25
Max. axial force ^{c)}	F_{2AMax}	N	2400														
		lb _f	540														
Max. lateral force ^{c)}	F_{2QMMax}	N	2800														
		lb _f	630														
Max. tilting moment	M_{2KMMax}	Nm	152														
		in.lb	1345														
Efficiency at full load	η	%	95														
Service life	L_n	h	> 20000														
Weight (incl. standard adapter plate)	m	kg	1.9														
		lb _m	4.2														
Operating noise (at reference ratio and reference speed – ratio-specific values available in cymex [®])	L_{PA}	dB(A)	≤ 58														
Max. permitted housing temperature		°C	+90														
		°F	+194														
Ambient temperature		°C	-15 to +40														
		°F	+5 to +104														
Lubrication			Lubricated for life														
Direction of rotation			In- and output same direction														
Protection class			IP 65														
Elastomer coupling (recommended product type – validate sizing with cymex [®])			ELC-0060BA016.000-X														
Bore diameter of coupling on the application side		mm	X = 012.000 - 032.000														
Mass moment of inertia (relates to the drive) Clamping hub diameter [mm]	Z	8	J_1	kgcm ²	0.04	0.04	0.03	0.03	0.03	0.03	0.03	0.03	0.03	0.02	0.02	0.02	0.02
				10 ⁻³ in.lb.s ²	0.04	0.04	0.03	0.03	0.03	0.03	0.03	0.03	0.03	0.03	0.02	0.02	0.02
	A	9	J_1	kgcm ²	0.04	0.04	0.03	0.03	0.03	0.03	0.03	0.03	0.03	0.02	0.02	0.02	0.02
				10 ⁻³ in.lb.s ²	0.04	0.04	0.03	0.03	0.03	0.03	0.03	0.03	0.03	0.03	0.02	0.02	0.02
	B	11	J_1	kgcm ²	0.06	0.06	0.05	0.05	0.05	0.05	0.05	0.04	0.05	0.04	0.04	0.04	
				10 ⁻³ in.lb.s ²	0.05	0.05	0.04	0.04	0.04	0.04	0.04	0.04	0.04	0.04	0.04	0.04	0.04
	C	14	J_1	kgcm ²	0.14	0.14	0.14	0.13	0.13	0.13	0.14	0.13	0.13	0.13	0.13	0.13	
				10 ⁻³ in.lb.s ²	0.12	0.12	0.12	0.12	0.12	0.12	0.12	0.12	0.12	0.12	0.12	0.12	0.12

Please use our sizing software cymex[®] for a detailed sizing – www.wittenstein-cymex.com

^{a)} Valid for torque transmission only

^{b)} Valid for standard clamping hub diameter

^{c)} Refers to center of the output shaft or flange

^{d)} Please reduce input speed at higher ambient temperatures

^{e)} Valid for: Smooth shaft

2-stage

Motor shaft diameter [mm]

up to 11⁴⁾ (B)⁵⁾
clamping hub diameter

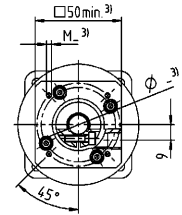
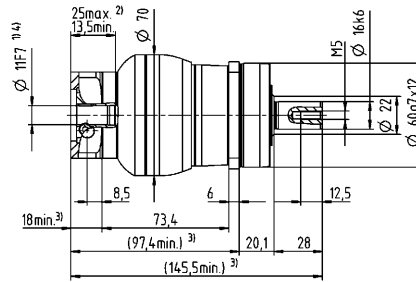
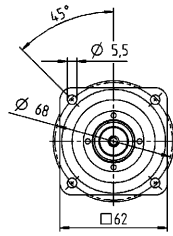

up to 14⁴⁾ (C)
clamping hub diameter

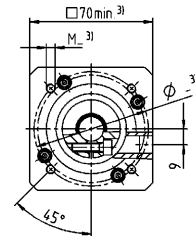
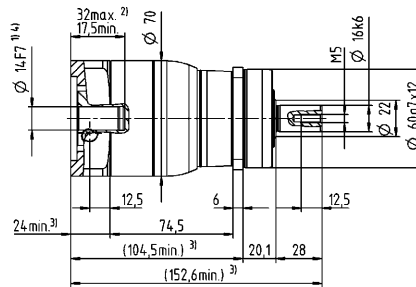
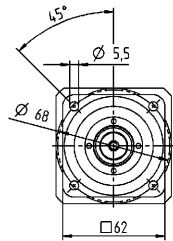

Other output variants

Shaft with key

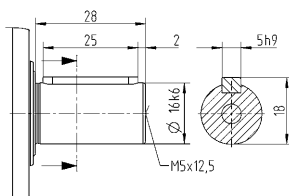

Splined shaft (DIN 5480)

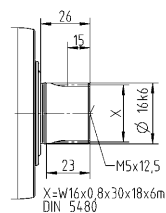

Non-tolerated dimensions are nominal dimensions

¹⁾ Check motor shaft fit

²⁾ Min. / Max. permissible motor shaft length

Longer motor shafts are possible, please contact alpha

³⁾ The dimensions depend on the motor

⁴⁾ Smaller motor shaft diameter is compensated

by a bushing with a minimum thickness of 1 mm

⁵⁾ Standard clamping hub diameter

NPS 025 MF 1-stage

			1-stage							
Ratio	i		3	4	5	7	8	10		
Max. torque ^{a) b) e)}	T_{2a}	Nm	128	152	160	160	144	144		
		in.lb	1133	1345	1416	1416	1275	1275		
Max. acceleration torque ^{e)} (max. 1000 cycles per hour)	T_{2B}	Nm	80	95	100	100	90	90		
		in.lb	708	841	885	885	797	797		
Emergency stop torque ^{a) b) e)} (permitted 1000 times during the service life of the gearbox)	T_{2Not}	Nm	190	190	190	190	190	190		
		in.lb	1682	1682	1682	1682	1682	1682		
Permitted average input speed ^{d)} (at T_{2N} and 20 °C ambient temperature)	n_{1N}	rpm	2700	2900	3000	3200	3300	3500		
Max. input speed	n_{1Max}	rpm	7000	7000	7000	7000	7000	7000		
Mean no load running torque ^{b)} (at $n_1=3000$ rpm and 20 °C gearbox temperature)	T_{012}	Nm	1.8	1.5	1.3	1.1	1	0.94		
		in.lb	16	13	12	9.7	8.9	8.3		
Max. backlash	j_l	arcmin	≤ 8							
Torsional rigidity ^{b)}	C_{i21}	Nm/arcmin	9.5	9.5	9.5	9.5	8.5	8.5		
		in.lb/arcmin	84	84	84	84	75	75		
Max. axial force ^{c)}	F_{2AMax}	N	3350							
		lb _f	754							
Max. lateral force ^{c)}	F_{2QMMax}	N	4200							
		lb _f	945							
Max. tilting moment	M_{2KMMax}	Nm	236							
		in.lb	2089							
Efficiency at full load	η	%	97							
Service life	L_n	h	> 20000							
Weight (incl. standard adapter plate)	m	kg	3.6							
		lb _m	8							
Operating noise (at reference ratio and reference speed – ratio-specific values available in cymex [®])	L_{PA}	dB(A)	≤ 61							
Max. permitted housing temperature		°C	+90							
		°F	+194							
Ambient temperature		°C	-15 to +40							
		°F	+5 to +104							
Lubrication			Lubricated for life							
Direction of rotation			In- and output same direction							
Protection class			IP 65							
Elastomer coupling (recommended product type – validate sizing with cymex [®])			ELC-0060BA022.000-X							
Bore diameter of coupling on the application side		mm	X = 012.000 - 032.000							
Mass moment of inertia (relates to the drive) Clamping hub diameter [mm]	C	14	J_1	kgcm ²	0.58	0.47	0.38	0.3	0.28	0.26
				10 ⁻³ in.lb.s ²	0.51	0.42	0.34	0.27	0.25	0.23
	D	16	J_1	kgcm ²	0.73	0.62	0.53	0.43	0.42	0.4
				10 ⁻³ in.lb.s ²	0.65	0.55	0.47	0.38	0.37	0.35
	E	19	J_1	kgcm ²	0.81	0.71	0.61	0.53	0.51	0.49
				10 ⁻³ in.lb.s ²	0.72	0.63	0.54	0.47	0.45	0.43
	G	24	J_1	kgcm ²	1.8	1.7	1.6	1.6	1.5	1.5
				10 ⁻³ in.lb.s ²	1.6	1.5	1.4	1.4	1.3	1.3
	H	28	J_1	kgcm ²	1.6	1.4	1.4	1.3	1.3	1.2
				10 ⁻³ in.lb.s ²	1.4	1.2	1.2	1.2	1.2	1.1

Please use our sizing software cymex[®] for a detailed sizing – www.wittenstein-cymex.com

^{a)} Valid for torque transmission only

^{b)} Valid for standard clamping hub diameter

^{c)} Refers to center of the output shaft or flange

^{d)} Please reduce input speed at higher ambient temperatures

^{e)} Valid for: Smooth shaft

1-stage

up to 19⁴⁾ (E)⁵⁾
clamping hub
diameter

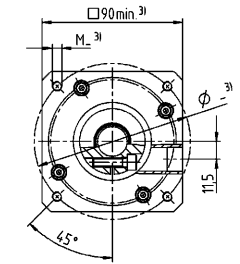
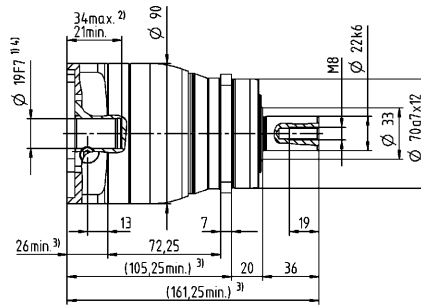
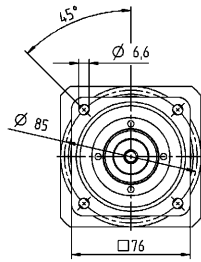

Motor shaft diameter [mm]

up to 28⁴⁾ (H)
clamping hub
diameter

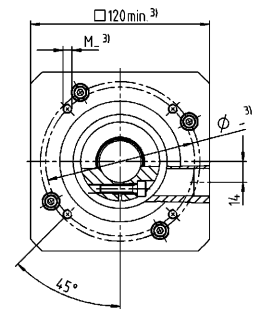
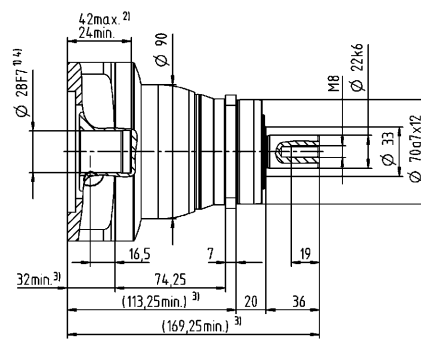
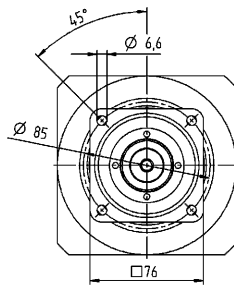

Other output variants

Shaft with key

Splined shaft (DIN 5480)

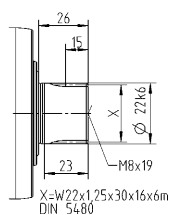
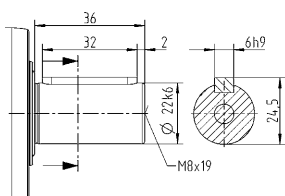

Non-tolerated dimensions are nominal dimensions

¹⁾ Check motor shaft fit

²⁾ Min. / Max. permissible motor shaft length

Longer motor shafts are possible, please contact alpha

³⁾ The dimensions depend on the motor

⁴⁾ Smaller motor shaft diameter is compensated

by a bushing with a minimum thickness of 1 mm

⁵⁾ Standard clamping hub diameter

NPS 025 MF 2-stage

			2-stage														
Ratio	i		9	12	15	16	20	25	28	30	32	35	40	50	64	70	100
Max. torque ^{a) b) e)}	T_{2a}	Nm	128	128	128	152	152	160	152	128	144	160	152	160	144	160	144
		in.lb	1133	1133	1133	1345	1345	1416	1345	1133	1275	1416	1345	1416	1275	1416	1275
Max. acceleration torque ^{e)} (max. 1000 cycles per hour)	T_{2B}	Nm	80	80	80	95	95	100	95	80	90	100	95	100	90	100	90
		in.lb	708	708	708	841	841	885	841	708	797	885	841	885	797	885	797
Emergency stop torque ^{a) b) e)} (permitted 1000 times during the service life of the gearbox)	T_{2Not}	Nm	190	190	190	190	190	190	190	190	190	190	190	190	190	190	190
		in.lb	1682	1682	1682	1682	1682	1682	1682	1682	1682	1682	1682	1682	1682	1682	1682
Permitted average input speed ^{d)} (at T_{2N} and 20 °C ambient temperature)	n_{1N}	rpm	2900	3500	3700	3500	3700	3700	4000	4300	4100	4000	4300	4300	4100	4300	4300
Max. input speed	n_{1Max}	rpm	8000	8000	8000	8000	8000	8000	8000	8000	8000	8000	8000	8000	8000	8000	8000
Mean no load running torque ^{b)} (at $n_1=3000$ rpm and 20 °C gearbox temperature)	T_{012}	Nm	0.67	0.55	0.47	0.46	0.4	0.36	0.34	0.33	0.32	0.31	0.29	0.27	0.25	0.25	0.23
		in.lb	5.9	4.9	4.2	4.1	3.5	3.2	3	2.9	2.8	2.7	2.6	2.4	2.2	2.2	2
Max. backlash	j_l	arcmin	≤ 10														
Torsional rigidity ^{b)}	C_{121}	Nm/arcmin	10	10	10	10	10	9.5	10	10	10	9.5	10	9.5	8.5	9.5	8.5
		in.lb/arcmin	89	89	89	89	89	84	89	89	89	84	89	84	75	84	75
Max. axial force ^{c)}	F_{2AMax}	N	3350														
		lb _f	754														
Max. lateral force ^{c)}	F_{2QMMax}	N	4200														
		lb _f	945														
Max. tilting moment	M_{2KMMax}	Nm	236														
		in.lb	2089														
Efficiency at full load	η	%	95														
Service life	L_n	h	> 20000														
Weight (incl. standard adapter plate)	m	kg	3.9														
		lb _m	8.6														
Operating noise (at reference ratio and reference speed – ratio-specific values available in cymex [®])	L_{PA}	dB(A)	≤ 59														
Max. permitted housing temperature		°C	+90														
		°F	+194														
Ambient temperature		°C	-15 to +40														
		°F	+5 to +104														
Lubrication			Lubricated for life														
Direction of rotation			In- and output same direction														
Protection class			IP 65														
Elastomer coupling (recommended product type – validate sizing with cymex [®])			ELC-0060BA022.000-X														
Bore diameter of coupling on the application side		mm	X = 012.000 - 032.000														
Mass moment of inertia (relates to the drive) Clamping hub diameter [mm]	A	9	J_1	kgcm ²	0.26	0.22	0.21	0.21	0.2	0.2	0.19	0.19	0.19	0.19	0.19	0.19	0.19
				10 ⁻³ in.lb.s ²	0.23	0.19	0.19	0.19	0.18	0.18	0.17	0.17	0.17	0.17	0.17	0.17	0.17
	B	11	J_1	kgcm ²	0.28	0.24	0.23	0.23	0.22	0.22	0.21	0.21	0.21	0.21	0.21	0.21	0.21
				10 ⁻³ in.lb.s ²	0.25	0.21	0.2	0.2	0.19	0.19	0.19	0.19	0.19	0.19	0.19	0.19	0.19
	C	14	J_1	kgcm ²	0.35	0.31	0.3	0.3	0.3	0.29	0.29	0.28	0.28	0.28	0.28	0.28	0.28
				10 ⁻³ in.lb.s ²	0.31	0.27	0.27	0.27	0.27	0.26	0.26	0.25	0.25	0.25	0.25	0.25	0.25
	D	16	J_1	kgcm ²	0.48	0.44	0.43	0.43	0.42	0.42	0.41	0.41	0.41	0.41	0.41	0.41	0.41
				10 ⁻³ in.lb.s ²	0.42	0.39	0.38	0.38	0.37	0.37	0.36	0.36	0.36	0.36	0.36	0.36	0.36
	E	19	J_1	kgcm ²	0.56	0.52	0.51	0.52	0.51	0.5	0.5	0.5	0.5	0.5	0.49	0.49	0.49
				10 ⁻³ in.lb.s ²	0.5	0.46	0.45	0.46	0.45	0.44	0.44	0.44	0.44	0.44	0.43	0.43	0.43

Please use our sizing software cymex[®] for a detailed sizing – www.wittenstein-cymex.com

^{a)} Valid for torque transmission only

^{b)} Valid for standard clamping hub diameter

^{c)} Refers to center of the output shaft or flange

^{d)} Please reduce input speed at higher ambient temperatures

^{e)} Valid for: Smooth shaft

2-stage

Motor shaft diameter [mm]

up to 14⁴⁾ (C)⁵⁾
clamping hub diameter

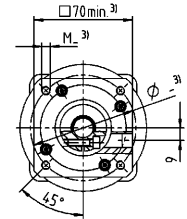
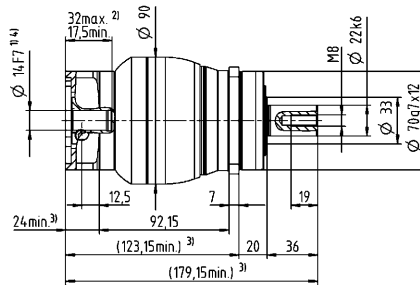
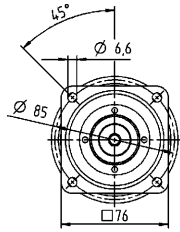

up to 19⁴⁾ (E)
clamping hub diameter

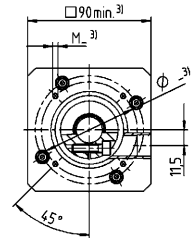
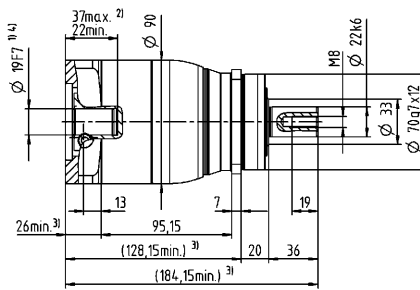
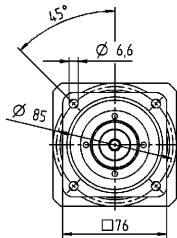

Planetary Gearboxes
Value Line

Other output variants

Shaft with key

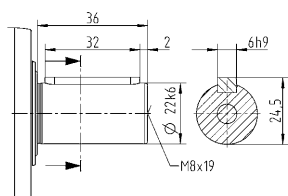

Splined shaft (DIN 5480)

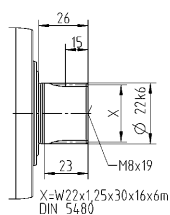

Non-tolerated dimensions are nominal dimensions

¹⁾ Check motor shaft fit

²⁾ Min. / Max. permissible motor shaft length

Longer motor shafts are possible, please contact alpha

³⁾ The dimensions depend on the motor

⁴⁾ Smaller motor shaft diameter is compensated

by a bushing with a minimum thickness of 1 mm

⁵⁾ Standard clamping hub diameter

NPS 035 MF 1-stage

			1-stage							
Ratio	i		3	4	5	7	8	10		
Max. torque ^{a) b) e)}	T_{2a}	Nm	320	408	400	400	352	352		
		in.lb	2832	3611	3540	3540	3115	3115		
Max. acceleration torque ^{e)} (max. 1000 cycles per hour)	T_{2B}	Nm	200	255	250	250	220	220		
		in.lb	1770	2257	2213	2213	1947	1947		
Emergency stop torque ^{a) b) e)} (permitted 1000 times during the service life of the gearbox)	T_{2Not}	Nm	500	500	500	500	500	500		
		in.lb	4425	4425	4425	4425	4425	4425		
Permitted average input speed ^{d)} (at T_{2a} and 20 °C ambient temperature)	n_{1N}	rpm	2000	2200	2300	2500	2600	2700		
Max. input speed	n_{1Max}	rpm	6000	6000	6000	6000	6000	6000		
Mean no load running torque ^{b)} (at $n_1=3000$ rpm and 20 °C gearbox temperature)	T_{012}	Nm	3.3	2.7	2.3	1.9	1.7	1.5		
		in.lb	29	24	20	17	15	13		
Max. backlash	j_l	arcmin	≤ 8							
Torsional rigidity ^{b)}	C_{i21}	Nm/arcmin	25	25	25	25	22	22		
		in.lb/arcmin	221	221	221	221	195	195		
Max. axial force ^{c)}	F_{2AMax}	N	5650							
		lb _f	1271							
Max. lateral force ^{c)}	F_{2QMMax}	N	6600							
		lb _f	1485							
Max. tilting moment	M_{2KMMax}	Nm	487							
		in.lb	4310							
Efficiency at full load	η	%	97							
Service life	L_n	h	> 20000							
Weight (incl. standard adapter plate)	m	kg	8.4							
		lb _m	19							
Operating noise (at reference ratio and reference speed – ratio-specific values available in cymex [®])	L_{PA}	dB(A)	≤ 65							
Max. permitted housing temperature		°C	+90							
		°F	+194							
Ambient temperature		°C	-15 to +40							
		°F	+5 to +104							
Lubrication			Lubricated for life							
Direction of rotation			In- and output same direction							
Protection class			IP 65							
Elastomer coupling (recommended product type – validate sizing with cymex [®])			ELC-0150BA032.000-X							
Bore diameter of coupling on the application side		mm	X = 019.000 - 036.000							
Mass moment of inertia (relates to the drive) Clamping hub diameter [mm]	E	19	J_1	kgcm ²	2.5	1.7	1.3	1	0.94	0.87
				10 ⁻³ in.lb.s ²	2.2	1.5	1.2	0.89	0.83	0.77
	G	24	J_1	kgcm ²	3.3	2.4	2.1	1.8	1.7	1.6
				10 ⁻³ in.lb.s ²	2.9	2.1	1.9	1.6	1.5	1.4
	H	28	J_1	kgcm ²	3	2.2	1.8	1.5	1.4	1.4
				10 ⁻³ in.lb.s ²	2.7	1.9	1.6	1.3	1.2	1.2
	I	32	J_1	kgcm ²	7.1	6.2	5.9	5.6	5.5	5.4
				10 ⁻³ in.lb.s ²	6.3	5.5	5.2	5	4.9	4.8
	K	38	J_1	kgcm ²	8.3	7.4	7.1	6.7	6.6	6.6
				10 ⁻³ in.lb.s ²	7.3	6.5	6.3	5.9	5.8	5.8

Please use our sizing software cymex[®] for a detailed sizing – www.wittenstein-cymex.com

^{a)} Valid for torque transmission only

^{b)} Valid for standard clamping hub diameter

^{c)} Refers to center of the output shaft or flange

^{d)} Please reduce input speed at higher ambient temperatures

^{e)} Valid for: Smooth shaft

1-stage

up to 24/28⁴⁾
(G⁵⁾/H)
clamping hub
diameter

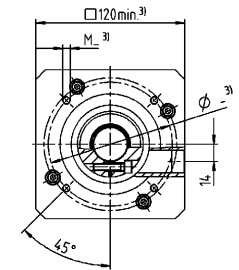
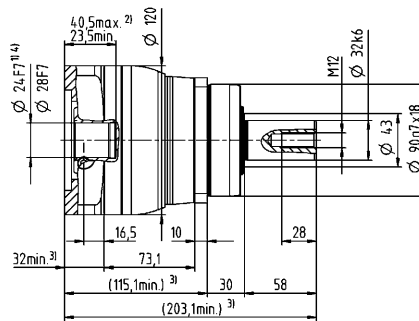
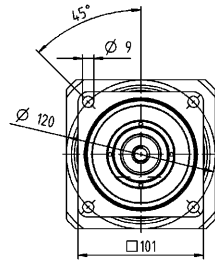

Motor shaft diameter [mm]

1-stage

up to 38⁴⁾ (K)
clamping hub
diameter

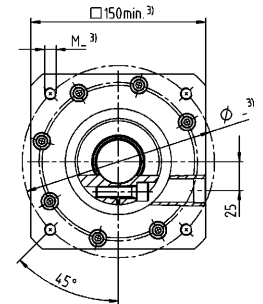
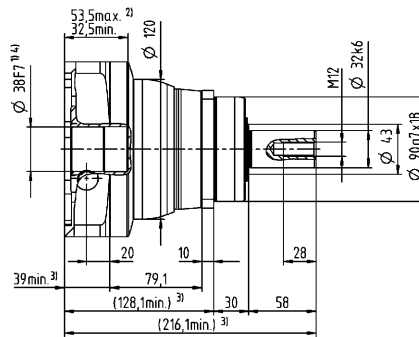
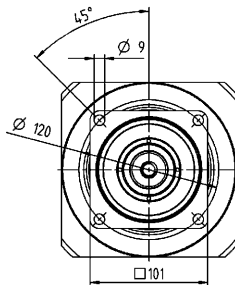

Other output variants

Shaft with key

Splined shaft (DIN 5480)

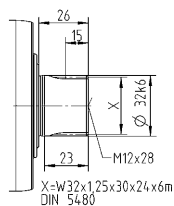
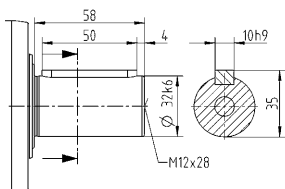

Non-tolerated dimensions are nominal dimensions

¹⁾ Check motor shaft fit

²⁾ Min. / Max. permissible motor shaft length

Longer motor shafts are possible, please contact alpha

³⁾ The dimensions depend on the motor

⁴⁾ Smaller motor shaft diameter is compensated

by a bushing with a minimum thickness of 1 mm

⁵⁾ Standard clamping hub diameter

NPS 035 MF 2-stage

			2-stage																
Ratio	i		9	12	15	16	20	25	28	30	32	35	40	50	64	70	100		
Max. torque ^{a) b) e)}	T_{2a}	Nm	320	320	320	408	408	400	408	320	408	400	408	400	352	400	352		
		in.lb	2832	2832	2832	3611	3611	3540	3611	2832	3611	3540	3611	3540	3115	3540	3115		
Max. acceleration torque ^{e)} (max. 1000 cycles per hour)	T_{2B}	Nm	200	200	200	255	255	250	255	200	255	250	255	250	220	250	220		
		in.lb	1770	1770	1770	2257	2257	2213	2257	1770	2257	2213	2257	2213	1947	2213	1947		
Emergency stop torque ^{a) b) e)} (permitted 1000 times during the service life of the gearbox)	T_{2Not}	Nm	500	500	500	500	500	500	500	500	500	500	500	500	500	500	500		
		in.lb	4425	4425	4425	4425	4425	4425	4425	4425	4425	4425	4425	4425	4425	4425	4425		
Permitted average input speed ^{d)} (at T_{2a} and 20 °C ambient temperature)	n_{1N}	rpm	2700	3300	3400	3300	3400	3400	3600	3900	3700	3600	3900	3900	3700	3900	3900		
Max. input speed	n_{1Max}	rpm	7000	7000	7000	7000	7000	7000	7000	7000	7000	7000	7000	7000	7000	7000	7000		
Mean no load running torque ^{b)} (at $n_1=3000$ rpm and 20 °C gearbox temperature)	T_{012}	Nm	1.7	1.4	1.2	1.2	1.1	1	0.93	0.88	0.88	0.87	0.81	0.77	0.75	0.72	0.68		
		in.lb	15	12	11	11	9.7	8.9	8.2	7.8	7.8	7.7	7.2	6.8	6.6	6.4	6		
Max. backlash	j_t	arcmin	≤ 10																
Torsional rigidity ^{b)}	C_{t21}	Nm/arcmin	25	25	25	25	25	25	25	25	25	25	25	25	22	25	22		
		in.lb/arcmin	221	221	221	221	221	221	221	221	221	221	221	221	195	221	195		
Max. axial force ^{c)}	F_{2AMax}	N	5650																
		lb _f	1271																
Max. lateral force ^{c)}	F_{2QMMax}	N	6600																
		lb _f	1485																
Max. tilting moment	M_{2KMMax}	Nm	487																
		in.lb	4310																
Efficiency at full load	η	%	95																
Service life	L_n	h	> 20000																
Weight (incl. standard adapter plate)	m	kg	8.8																
		lb _m	19																
Operating noise (at reference ratio and reference speed – ratio-specific values available in cymex [®])	L_{PA}	dB(A)	≤ 61																
Max. permitted housing temperature		°C	+90																
		°F	+194																
Ambient temperature		°C	-15 to +40																
		°F	+5 to +104																
Lubrication			Lubricated for life																
Direction of rotation			In- and output same direction																
Protection class			IP 65																
Elastomer coupling (recommended product type – validate sizing with cymex [®])			ELC-0150BA032.000-X																
Bore diameter of coupling on the application side		mm	X = 019.000 - 036.000																
Mass moment of inertia (relates to the drive) Clamping hub diameter [mm]	C	14	J_1	kgcm ²	0.6	0.59	0.6	0.43	0.42	0.36	0.37	0.52	0.38	0.32	0.36	0.31	0.26	0.27	0.24
				10 ⁻³ in.lb.s ²	0.53	0.52	0.53	0.38	0.37	0.32	0.33	0.46	0.34	0.28	0.32	0.27	0.23	0.24	0.21
	D	16	J_1	kgcm ²	0.75	0.74	0.74	0.58	0.57	0.5	0.5	0.67	0.52	0.45	0.51	0.46	0.4	0.41	0.39
				10 ⁻³ in.lb.s ²	0.66	0.65	0.65	0.51	0.5	0.44	0.44	0.59	0.46	0.4	0.45	0.41	0.35	0.36	0.35
	E	19	J_1	kgcm ²	0.84	0.83	0.83	0.66	0.65	0.59	0.6	0.75	0.61	0.55	0.6	0.54	0.49	0.5	0.48
				10 ⁻³ in.lb.s ²	0.74	0.73	0.73	0.58	0.58	0.52	0.53	0.66	0.54	0.49	0.53	0.48	0.43	0.44	0.42
	G	24	J_1	kgcm ²	1.9	1.9	1.9	1.7	1.7	1.6	1.6	1.8	1.6	1.6	1.6	1.6	1.5	1.5	1.5
				10 ⁻³ in.lb.s ²	1.7	1.6	1.7	1.5	1.5	1.4	1.5	1.6	1.5	1.4	1.4	1.4	1.3	1.4	1.3
	H	28	J_1	kgcm ²	1.6	1.6	1.6	1.4	1.4	1.3	1.3	1.5	1.4	1.3	1.3	1.3	1.2	1.2	1.2
				10 ⁻³ in.lb.s ²	1.4	1.4	1.4	1.2	1.2	1.2	1.2	1.3	1.2	1.1	1.2	1.1	1.1	1.1	1.1

Please use our sizing software cymex[®] for a detailed sizing – www.wittenstein-cymex.com

^{a)} Valid for torque transmission only

^{b)} Valid for standard clamping hub diameter

^{c)} Refers to center of the output shaft or flange

^{d)} Please reduce input speed at higher ambient temperatures

^{e)} Valid for: Smooth shaft

2-stage

Motor shaft diameter [mm]

up to 19⁴⁾ (E)⁵⁾
clamping hub diameter

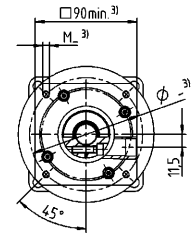
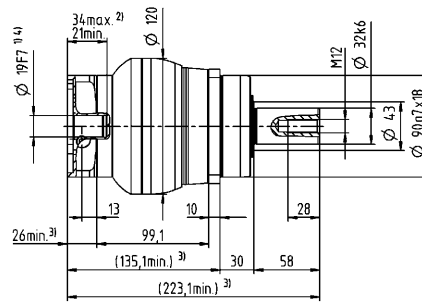
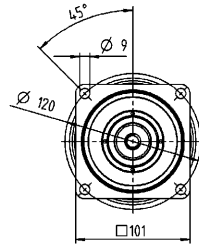

up to 28⁴⁾ (H)
clamping hub diameter

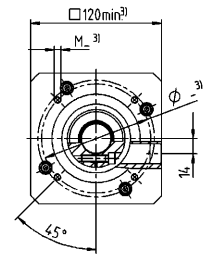
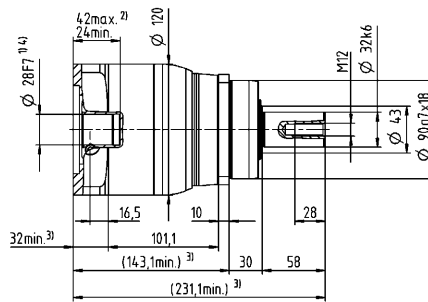
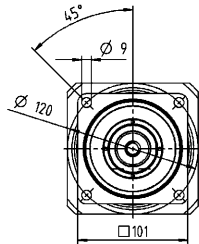

Planetary Gearboxes
Value Line

Other output variants

Shaft with key

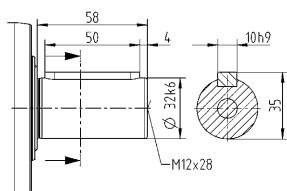

Splined shaft (DIN 5480)

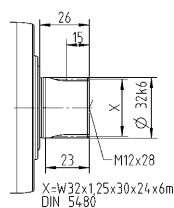

Non-tolerated dimensions are nominal dimensions

¹⁾ Check motor shaft fit

²⁾ Min. / Max. permissible motor shaft length

Longer motor shafts are possible, please contact alpha

³⁾ The dimensions depend on the motor

⁴⁾ Smaller motor shaft diameter is compensated

by a bushing with a minimum thickness of 1 mm

⁵⁾ Standard clamping hub diameter

NPS 045 MF 1-/2-stage

			1-stage			2-stage						
Ratio	i		5	8	10	25	32	50	64	100		
Max. torque ^{a) b) e)}	T_{2a}	Nm	800	640	640	700	640	700	640	640		
		in.lb	7081	5665	5665	6196	5665	6196	5665	5665		
Max. acceleration torque ^{e)} (max. 1000 cycles per hour)	T_{2B}	Nm	500	400	400	500	400	500	400	400		
		in.lb	4425	3540	3540	4425	3540	4425	3540	3540		
Emergency stop torque ^{a) b) e)} (permitted 1000 times during the service life of the gearbox)	T_{2Not}	Nm	1000	1000	1000	1000	1000	1000	1000	1000		
		in.lb	8851	8851	8851	8851	8851	8851	8851	8851		
Permitted average input speed ^{d)} (at T_{2a} and 20 °C ambient temperature)	n_{1N}	rpm	1800	1900	2000	2600	2500	3000	2900	3000		
Max. input speed	n_{1Max}	rpm	4000	4000	4000	6000	6000	6000	6000	6000		
Mean no load running torque ^{b)} (at $n_1=3000$ rpm and 20 °C gearbox temperature)	T_{012}	Nm	4.2	3	2.6	1.6	1.5	1.2	1.1	0.97		
		in.lb	37	27	23	14	13	11	9.7	8.6		
Max. backlash	j_l	arcmin	≤ 8			≤ 10						
Torsional rigidity ^{b)}	C_{i21}	Nm/arcmin	55	44	44	55	44	55	44	44		
		in.lb/arcmin	487	389	389	487	389	487	389	389		
Max. axial force ^{c)}	F_{2AMax}	N	9870			9870						
		lb _f	2221			2221						
Max. lateral force ^{c)}	F_{2QMMax}	N	9900			9900						
		lb _f	2228			2228						
Max. tilting moment	M_{2KMMax}	Nm	952			952						
		in.lb	8426			8426						
Efficiency at full load	η	%	97			95						
Service life	L_n	h	> 20000			> 20000						
Weight (incl. standard adapter plate)	m	kg	19			19						
		lb _m	42			42						
Operating noise (at reference ratio and reference speed – ratio-specific values available in cymex [®])	L_{PA}	dB(A)	≤ 68			≤ 65						
Max. permitted housing temperature		°C	+90			+90						
		°F	+194			+194						
Ambient temperature		°C	-15 to +40			-15 to +40						
		°F	+5 to +104			+5 to +104						
Lubrication			Lubricated for life									
Direction of rotation			In- and output same direction									
Protection class			IP 65									
Elastomer coupling (recommended product type – validate sizing with cymex [®])			ELC-0300BA040.000-X									
Bore diameter of coupling on the application side		mm	X = 020.000 - 045.000									
Mass moment of inertia (relates to the drive) Clamping hub diameter [mm]	E	19	J_1	kgcm ²	-	-	-	1.2	1.1	1	0.88	0.82
				10 ⁻³ in.lb.s ²	-	-	-	1.1	0.97	0.89	0.78	0.73
	G	24	J_1	kgcm ²	-	-	-	2	1.9	1.8	1.7	1.6
				10 ⁻³ in.lb.s ²	-	-	-	1.8	1.7	1.6	1.5	1.4
	H	28	J_1	kgcm ²	-	-	-	1.7	1.6	1.5	1.4	1.3
				10 ⁻³ in.lb.s ²	-	-	-	1.5	1.4	1.3	1.2	1.2
	I	32	J_1	kgcm ²	-	-	-	5.8	5.7	5.6	5.4	5.4
				10 ⁻³ in.lb.s ²	-	-	-	5.1	5	5	4.8	4.8
	K	38	J_1	kgcm ²	8.7	7.3	7.2	7	6.9	6.8	6.6	6.5
				10 ⁻³ in.lb.s ²	7.7	6.5	6.4	6.2	6.1	6	5.8	5.8

Please use our sizing software cymex[®] for a detailed sizing – www.wittenstein-cymex.com

^{a)} Valid for torque transmission only

^{b)} Valid for standard clamping hub diameter

^{c)} Refers to center of the output shaft or flange

^{d)} Please reduce input speed at higher ambient temperatures

^{e)} Valid for: Smooth shaft

1-stage

up to 38⁴⁾ (K)⁵⁾
clamping hub
diameter

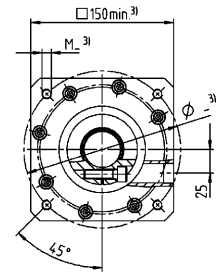
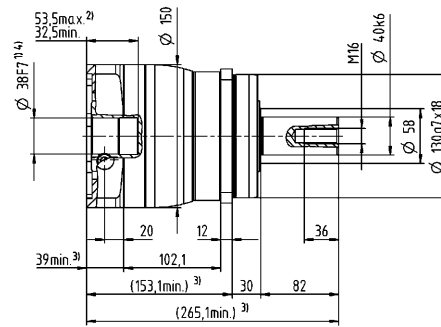
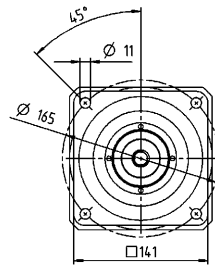

2-stage

up to 28⁴⁾ (H)⁵⁾
clamping hub
diameter

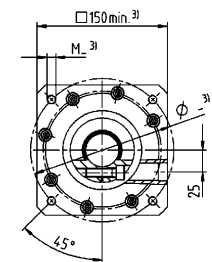
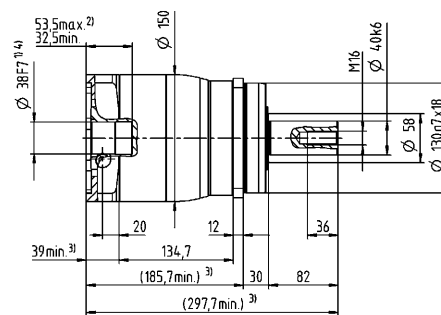
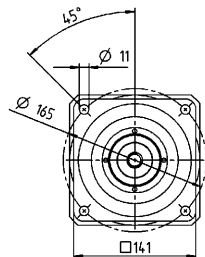
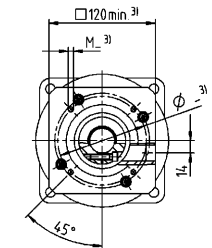
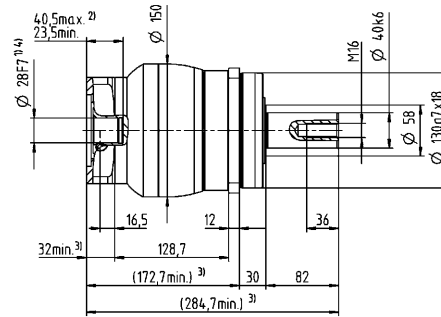
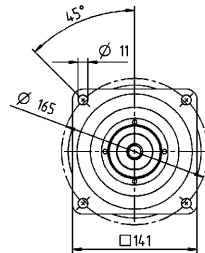

Motor shaft diameter [mm]

up to 38⁴⁾ (K)⁵⁾
clamping hub
diameter

Other output variants

Shaft with key

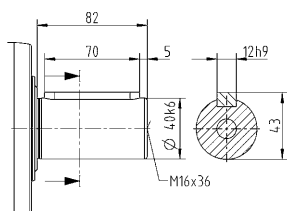

Splined shaft (DIN 5480)

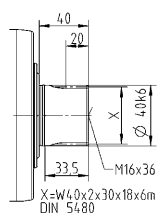

Non-tolerated dimensions are nominal dimensions

¹⁾ Check motor shaft fit

²⁾ Min. / Max. permissible motor shaft length

Longer motor shafts are possible, please contact alpha

³⁾ The dimensions depend on the motor

⁴⁾ Smaller motor shaft diameter is compensated

by a bushing with a minimum thickness of 1 mm

⁵⁾ Standard clamping hub diameter

NPS 015 MA 1-/2-stage

			1-stage		2-stage							
Ratio	i		3	4	12	15	16	20	28	30	40	
Max. torque ^{a) b) e)}	T_{2a}	Nm	80	67	62	67	67	67	67	62	67	
		in.lb	708	593	549	593	593	593	593	593	549	593
Max. acceleration torque ^{e)} (max. 1000 cycles per hour)	T_{2B}	Nm	55	42	39	42	42	42	42	42	39	42
		in.lb	487	372	345	372	372	372	372	372	345	372
Emergency stop torque ^{a) b) e)} (permitted 1000 times during the service life of the gearbox)	T_{2Not}	Nm	80	80	80	80	80	80	80	80	80	80
		in.lb	708	708	708	708	708	708	708	708	708	708
Permitted average input speed ^{d)} (at T_{2N} and 20 °C ambient temperature)	n_{1N}	rpm	2900	3100	3800	4000	3800	4000	4300	4600	4600	
Max. input speed	n_{1Max}	rpm	8000	8000	10000	10000	10000	10000	10000	10000	10000	
Mean no load running torque ^{b)} (at $n_1=3000$ rpm and 20 °C gearbox temperature)	T_{012}	Nm	0.92	0.74	0.34	0.29	0.29	0.25	0.21	0.21	0.19	
		in.lb	8.1	6.5	3	2.6	2.6	2.2	1.9	1.9	1.7	
Max. backlash	j_l	arcmin	≤ 8		≤ 10							
Torsional rigidity ^{b)}	C_{121}	Nm/arcmin	4	4	4	4	4	4	4	4	4	
		in.lb/arcmin	35	35	35	35	35	35	35	35	35	
Max. axial force ^{c)}	F_{2AMax}	N	2400		2400							
		lb _f	540		540							
Max. lateral force ^{c)}	F_{2QMMax}	N	2800		2800							
		lb _f	630		630							
Max. tilting moment	M_{2KMMax}	Nm	152		152							
		in.lb	1345		1345							
Efficiency at full load	η	%	97		95							
Service life	L_h	h	> 20000		> 20000							
Weight (incl. standard adapter plate)	m	kg	1.8		1.9							
		lb _m	4		4.2							
Operating noise (at reference ratio and reference speed – ratio-specific values available in cymex®)	L_{PA}	dB(A)	≤ 59		≤ 58							
Max. permitted housing temperature		°C	+90		+90							
		°F	+194		+194							
Ambient temperature		°C	-15 to +40		-15 to +40							
		°F	+5 to +104		+5 to +104							
Lubrication			Lubricated for life									
Direction of rotation			In- and output same direction									
Protection class			IP 65									
Elastomer coupling (recommended product type – validate sizing with cymex®)			ELC-0060BA016.000-X									
Bore diameter of coupling on the application side		mm	X = 012.000 - 032.000									
Mass moment of inertia (relates to the drive) Clamping hub diameter [mm]	Z	8	J_1	kgcm ²	-	-	0.04	0.04	0.03	0.03	0.03	0.03
				10 ⁻³ in.lb.s ²	-	-	0.04	0.04	0.03	0.03	0.03	0.03
	A	9	J_1	kgcm ²	0.25	0.19	0.04	0.04	0.03	0.03	0.03	0.03
				10 ⁻³ in.lb.s ²	0.22	0.17	0.04	0.04	0.03	0.03	0.03	0.03
	B	11	J_1	kgcm ²	0.26	0.21	0.06	0.06	0.05	0.05	0.05	0.05
				10 ⁻³ in.lb.s ²	0.23	0.19	0.05	0.05	0.04	0.04	0.04	0.04
	C	14	J_1	kgcm ²	0.34	0.28	0.14	0.14	0.14	0.13	0.13	0.14
				10 ⁻³ in.lb.s ²	0.3	0.25	0.12	0.12	0.12	0.12	0.12	0.12
	D	16	J_1	kgcm ²	0.47	0.41	-	-	-	-	-	-
				10 ⁻³ in.lb.s ²	0.42	0.36	-	-	-	-	-	-
	E	19	J_1	kgcm ²	0.55	0.49	-	-	-	-	-	-
				10 ⁻³ in.lb.s ²	0.49	0.43	-	-	-	-	-	-

Please use our sizing software cymex® for a detailed sizing – www.wittenstein-cymex.com

^{a)} Valid for torque transmission only

^{b)} Valid for standard clamping hub diameter

^{c)} Refers to center of the output shaft or flange

^{d)} Please reduce input speed at higher ambient temperatures

^{e)} Valid for: Smooth shaft

1-stage

up to 14⁴⁾ (C)⁵⁾
clamping hub diameter

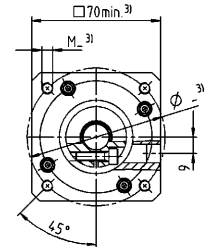
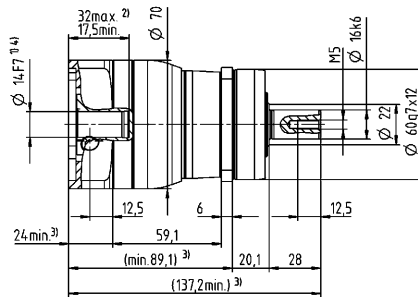
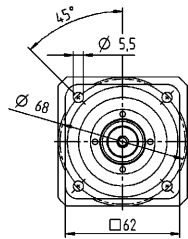

up to 19⁴⁾ (E)
clamping hub diameter

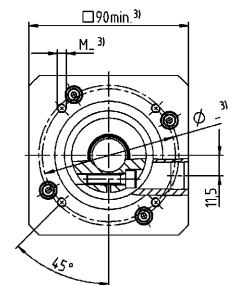
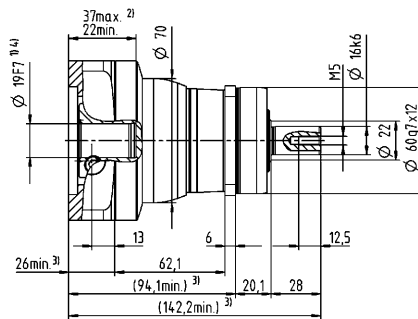
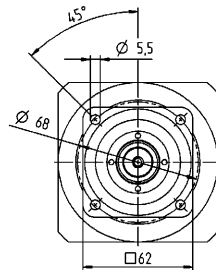

2-stage

up to 11⁴⁾ (B)⁵⁾
clamping hub diameter

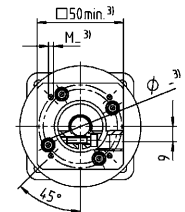
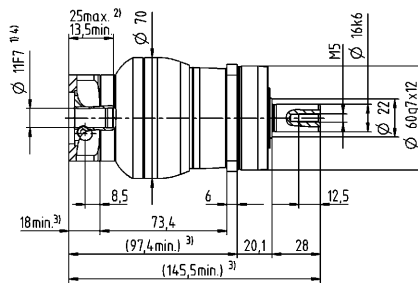
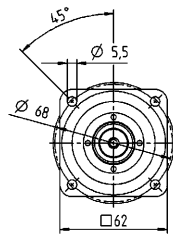

up to 14⁴⁾ (C)
clamping hub diameter

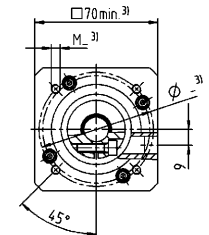
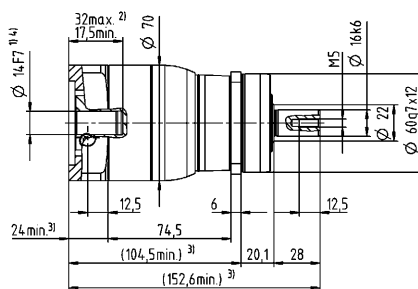
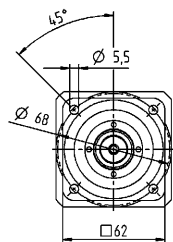

Motor shaft diameter [mm]

Other output variants

Shaft with key

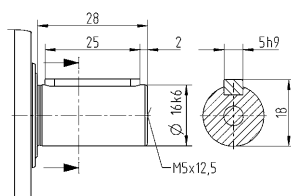

Splined shaft (DIN 5480)

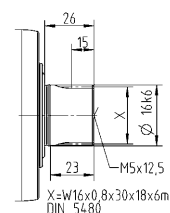

Non-tolerated dimensions are nominal dimensions

¹⁾ Check motor shaft fit

²⁾ Min. / Max. permissible motor shaft length

Longer motor shafts are possible, please contact alpha

³⁾ The dimensions depend on the motor

⁴⁾ Smaller motor shaft diameter is compensated

by a bushing with a minimum thickness of 1 mm

⁵⁾ Standard clamping hub diameter

NPS 025 MA 1-/2-stage

			1-stage		2-stage									
Ratio	i		3	4	9	12	15	16	20	28	30	40		
Max. torque ^{a) b) e)}	T_{2a}	Nm	185	185	185	185	185	185	185	185	168	185		
		in.lb	1637	1637	1637	1637	1637	1637	1637	1637	1637	1487	1637	
Max. acceleration torque ^{e)} (max. 1000 cycles per hour)	T_{2B}	Nm	125	115	125	125	120	115	115	115	105	115		
		in.lb	1106	1018	1106	1106	1062	1018	1018	1018	929	1018		
Emergency stop torque ^{a) b) e)} (permitted 1000 times during the service life of the gearbox)	T_{2Not}	Nm	190	190	190	190	190	190	190	190	190	190		
		in.lb	1682	1682	1682	1682	1682	1682	1682	1682	1682	1682		
Permitted average input speed ^{d)} (at T_{2N} and 20 °C ambient temperature)	n_{1N}	rpm	2700	2900	2900	3500	3700	3500	3700	4000	4300	4300		
Max. input speed	n_{1Max}	rpm	7000	7000	8000	8000	8000	8000	8000	8000	8000	8000		
Mean no load running torque ^{b)} (at $n_1=3000$ rpm and 20 °C gearbox temperature)	T_{012}	Nm	1.8	1.5	0.67	0.55	0.47	0.46	0.4	0.34	0.33	0.29		
		in.lb	16	13	5.9	4.9	4.2	4.1	3.5	3	2.9	2.6		
Max. backlash	j_l	arcmin	≤ 8		≤ 10									
Torsional rigidity ^{b)}	C_{i21}	Nm/arcmin	12	12	12	12	12	12	12	12	12	12		
		in.lb/arcmin	106	106	106	106	106	106	106	106	106	106		
Max. axial force ^{c)}	F_{2AMax}	N	3350		3350									
		lb _f	754		754									
Max. lateral force ^{c)}	F_{2QMMax}	N	4200		4200									
		lb _f	945		945									
Max. tilting moment	M_{2KMMax}	Nm	236		236									
		in.lb	2089		2089									
Efficiency at full load	η	%	97		95									
Service life	L_n	h	> 20000		> 20000									
Weight (incl. standard adapter plate)	m	kg	3.6		3.9									
		lb _m	8		8.6									
Operating noise (at reference ratio and reference speed – ratio-specific values available in cymex®)	L_{PA}	dB(A)	≤ 61		≤ 59									
Max. permitted housing temperature		°C	+90		+90									
		°F	+194		+194									
Ambient temperature		°C	-15 to +40		-15 to +40									
		°F	+5 to +104		+5 to +104									
Lubrication			Lubricated for life											
Direction of rotation			In- and output same direction											
Protection class			IP 65											
Elastomer coupling (recommended product type – validate sizing with cymex®)			ELC-0060BA022.000-X											
Bore diameter of coupling on the application side		mm	X = 012.000 - 032.000											
Mass moment of inertia (relates to the drive) Clamping hub diameter [mm]	A	9	J_1	kgcm ²	-	-	0.26	0.22	0.21	0.21	0.2	0.19	0.19	0.19
				10 ⁻³ in.lb.s ²	-	-	0.23	0.19	0.19	0.19	0.18	0.17	0.17	0.17
	B	11	J_1	kgcm ²	-	-	0.28	0.24	0.23	0.23	0.22	0.21	0.21	0.21
				10 ⁻³ in.lb.s ²	-	-	0.25	0.21	0.2	0.2	0.19	0.19	0.19	0.19
	C	14	J_1	kgcm ²	0.58	0.47	0.35	0.31	0.3	0.3	0.3	0.29	0.28	0.28
				10 ⁻³ in.lb.s ²	0.51	0.42	0.31	0.27	0.27	0.27	0.27	0.26	0.25	0.25
	D	16	J_1	kgcm ²	0.73	0.62	0.48	0.44	0.43	0.43	0.42	0.41	0.41	0.41
				10 ⁻³ in.lb.s ²	0.65	0.55	0.42	0.39	0.38	0.38	0.37	0.36	0.36	0.36
	E	19	J_1	kgcm ²	0.81	0.71	0.56	0.52	0.51	0.52	0.51	0.5	0.5	0.49
				10 ⁻³ in.lb.s ²	0.72	0.63	0.5	0.46	0.45	0.46	0.45	0.44	0.44	0.43
	G	24	J_1	kgcm ²	1.8	1.7	-	-	-	-	-	-	-	-
				10 ⁻³ in.lb.s ²	1.6	1.5	-	-	-	-	-	-	-	-
	H	28	J_1	kgcm ²	1.6	1.4	-	-	-	-	-	-	-	-
				10 ⁻³ in.lb.s ²	1.4	1.2	-	-	-	-	-	-	-	-

Please use our sizing software cymex® for a detailed sizing – www.wittenstein-cymex.com

^{a)} Valid for torque transmission only

^{b)} Valid for standard clamping hub diameter

^{c)} Refers to center of the output shaft or flange

^{d)} Please reduce input speed at higher ambient temperatures

^{e)} Valid for: Smooth shaft

1-stage

up to 19⁴⁾ (E)⁵⁾
clamping hub diameter

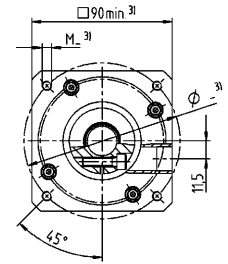
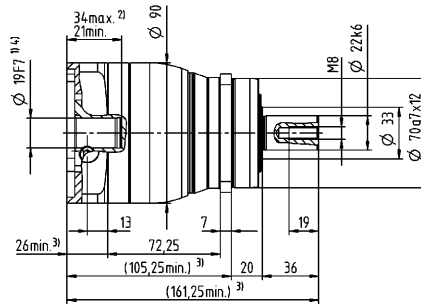
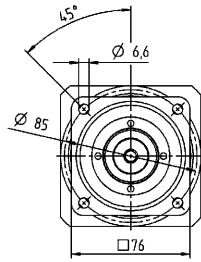

up to 28⁴⁾ (H)
clamping hub diameter

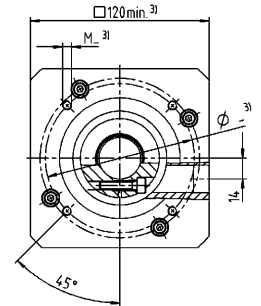
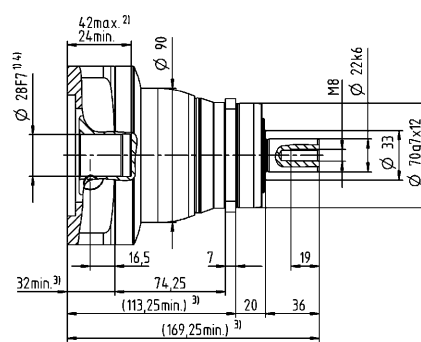
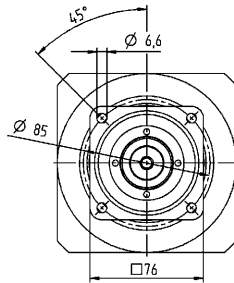

2-stage

up to 14⁴⁾ (C)⁵⁾
clamping hub diameter

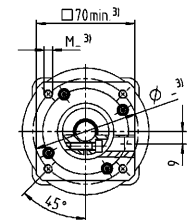
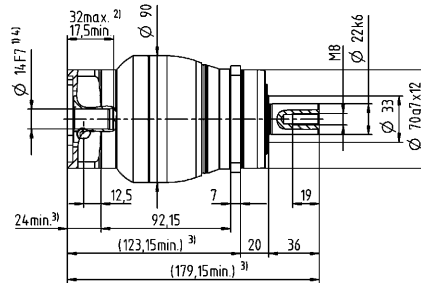
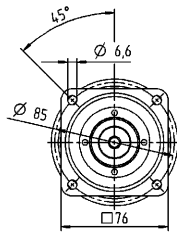

up to 19⁴⁾ (E)
clamping hub diameter

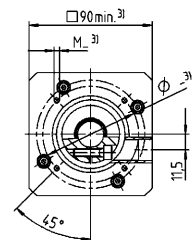
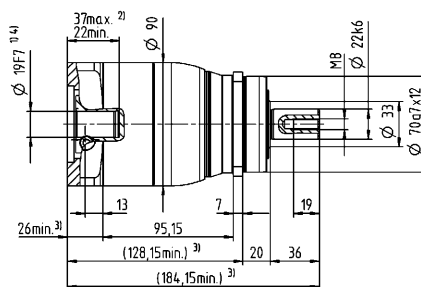
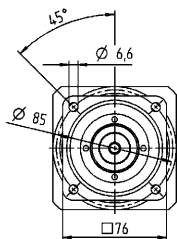

Motor shaft diameter [mm]

Other output variants

Shaft with key

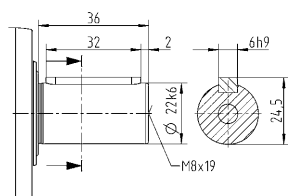

Splined shaft (DIN 5480)

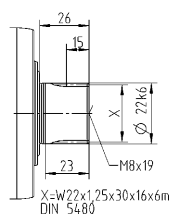

Non-tolerated dimensions are nominal dimensions

¹⁾ Check motor shaft fit

²⁾ Min. / Max. permissible motor shaft length

Longer motor shafts are possible, please contact alpha

³⁾ The dimensions depend on the motor

⁴⁾ Smaller motor shaft diameter is compensated

by a bushing with a minimum thickness of 1 mm

⁵⁾ Standard clamping hub diameter

NPS 035 MA 1-/2-stage

			1-stage		2-stage									
Ratio	i		3	4	9	12	15	16	20	28	30	40		
Max. torque ^{a) b) e)}	T_{2a}	Nm	480	480	480	480	480	480	480	480	432	480		
		in.lb	4248	4248	4248	4248	4248	4248	4248	4248	4248	3824	4248	
Max. acceleration torque ^{e)} (max. 1000 cycles per hour)	T_{2B}	Nm	305	305	305	305	300	305	305	305	270	305		
		in.lb	2699	2699	2699	2699	2655	2699	2699	2699	2390	2699		
Emergency stop torque ^{a) b) e)} (permitted 1000 times during the service life of the gearbox)	T_{2Not}	Nm	500	500	500	500	500	500	500	500	500	500		
		in.lb	4425	4425	4425	4425	4425	4425	4425	4425	4425	4425		
Permitted average input speed ^{d)} (at T_{2N} and 20 °C ambient temperature)	n_{1N}	rpm	2000	2200	2700	3300	3400	3300	3400	3600	3900	3900		
Max. input speed	n_{1Max}	rpm	6000	6000	7000	7000	7000	7000	7000	7000	7000	7000		
Mean no load running torque ^{b)} (at $n_1=3000$ rpm and 20 °C gearbox temperature)	T_{012}	Nm	3.3	2.7	1.7	1.4	1.2	1.2	1.1	0.93	0.88	0.81		
		in.lb	29	24	15	12	11	11	9.7	8.2	7.8	7.2		
Max. backlash	j_l	arcmin	≤ 8		≤ 10									
Torsional rigidity ^{b)}	C_{i21}	Nm/arcmin	30	30	30	30	30	30	30	30	30	30		
		in.lb/arcmin	266	266	266	266	266	266	266	266	266	266		
Max. axial force ^{c)}	F_{2AMax}	N	5650		5650									
		lb _f	1271		1271									
Max. lateral force ^{c)}	F_{2QMMax}	N	6600		6600									
		lb _f	1485		1485									
Max. tilting moment	M_{2KMMax}	Nm	487		487									
		in.lb	4310		4310									
Efficiency at full load	η	%	97		95									
Service life	L_n	h	> 20000		> 20000									
Weight (incl. standard adapter plate)	m	kg	8.4		8.8									
		lb _m	19		19									
Operating noise (at reference ratio and reference speed – ratio-specific values available in cymex®)	L_{PA}	dB(A)	≤ 65		≤ 61									
			+90		+90									
Max. permitted housing temperature		°C	+90		+90									
		°F	+194		+194									
Ambient temperature		°C	-15 to +40		-15 to +40									
		°F	+5 to +104		+5 to +104									
Lubrication			Lubricated for life											
Direction of rotation			In- and output same direction											
Protection class			IP 65											
Elastomer coupling (recommended product type – validate sizing with cymex®)			ELC-0150BA032.000-X											
Bore diameter of coupling on the application side		mm	X = 019.000 - 036.000											
Mass moment of inertia (relates to the drive) Clamping hub diameter [mm]	C	14	J_1	kgcm ²	-	-	0.6	0.59	0.6	0.43	0.42	0.37	0.52	0.36
				10 ⁻³ in.lb.s ²	-	-	0.53	0.52	0.53	0.38	0.37	0.33	0.46	0.32
	D	16	J_1	kgcm ²	-	-	0.75	0.74	0.74	0.58	0.57	0.5	0.67	0.51
				10 ⁻³ in.lb.s ²	-	-	0.66	0.65	0.65	0.51	0.5	0.44	0.59	0.45
	E	19	J_1	kgcm ²	2.5	1.7	0.84	0.83	0.83	0.66	0.65	0.6	0.75	0.6
				10 ⁻³ in.lb.s ²	2.2	1.5	0.74	0.73	0.73	0.58	0.58	0.53	0.66	0.53
	G	24	J_1	kgcm ²	3.3	2.4	1.9	1.9	1.9	1.7	1.7	1.6	1.8	1.6
				10 ⁻³ in.lb.s ²	2.9	2.1	1.7	1.6	1.7	1.5	1.5	1.5	1.6	1.4
	H	28	J_1	kgcm ²	3	2.2	1.6	1.6	1.6	1.4	1.4	1.3	1.5	1.3
				10 ⁻³ in.lb.s ²	2.7	1.9	1.4	1.4	1.4	1.2	1.2	1.2	1.3	1.2
	I	32	J_1	kgcm ²	7.1	6.2	-	-	-	-	-	-	-	-
				10 ⁻³ in.lb.s ²	6.3	5.5	-	-	-	-	-	-	-	-
K	38	J_1	kgcm ²	8.3	7.4	-	-	-	-	-	-	-	-	
			10 ⁻³ in.lb.s ²	7.3	6.5	-	-	-	-	-	-	-	-	

Please use our sizing software cymex® for a detailed sizing – www.wittenstein-cymex.com

^{a)} Valid for torque transmission only

^{b)} Valid for standard clamping hub diameter

^{c)} Refers to center of the output shaft or flange

^{d)} Please reduce input speed at higher ambient temperatures

^{e)} Valid for: Smooth shaft

1-stage

up to 24⁴⁾ (G⁵⁾/H)
clamping hub diameter

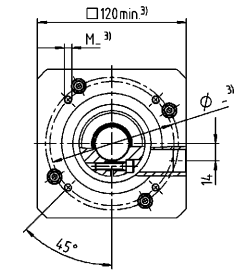
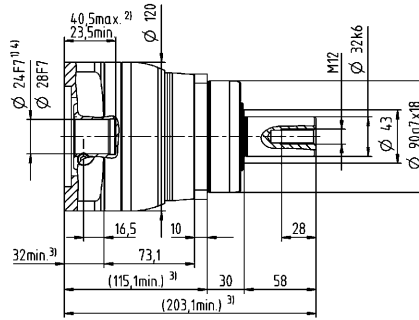
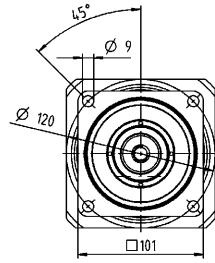

up to 38⁴⁾ (K)
clamping hub diameter

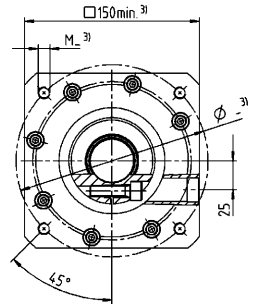
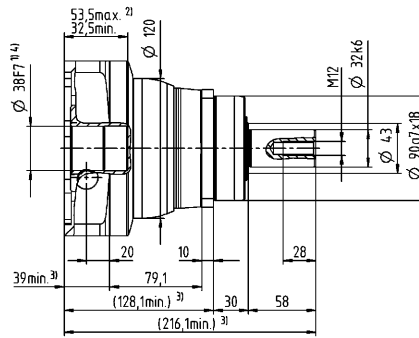
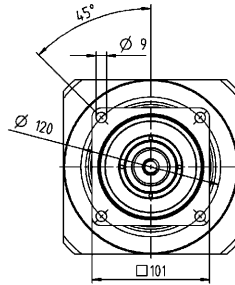

2-stage

up to 19⁴⁾ (E)⁵⁾
clamping hub diameter

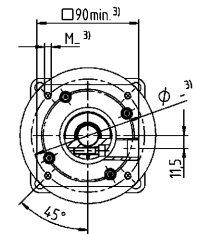
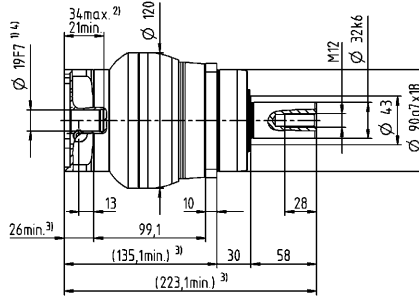
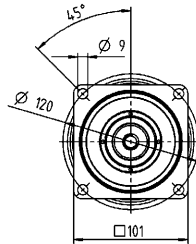

up to 28⁴⁾ (H)
clamping hub diameter

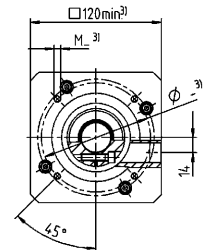
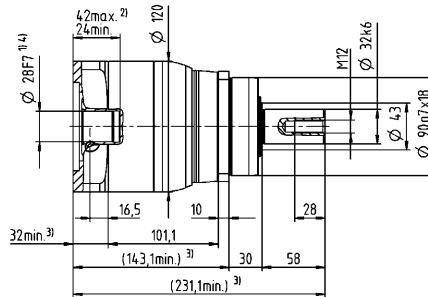
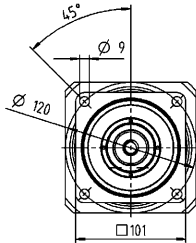

Motor shaft diameter [mm]

Other output variants

Shaft with key

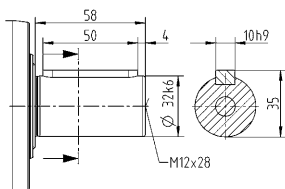

Splined shaft (DIN 5480)

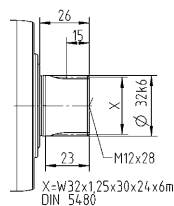

Non-tolerated dimensions are nominal dimensions

¹⁾ Check motor shaft fit

²⁾ Min. / Max. permissible motor shaft length

Longer motor shafts are possible, please contact alpha

³⁾ The dimensions depend on the motor

⁴⁾ Smaller motor shaft diameter is compensated

by a bushing with a minimum thickness of 1 mm

⁵⁾ Standard clamping hub diameter

NPT 005 MF 1-stage

			1-stage						
Ratio	i		4	5	7	8	10		
Max. torque ^{a) b)}	T_{2a}	Nm	18	22	22	21	21		
		in.lb	159	195	195	186	186		
Max. acceleration torque (max. 1000 cycles per hour)	T_{2B}	Nm	11	14	14	13	13		
		in.lb	97	124	124	115	115		
Emergency stop torque ^{a) b)} (permitted 1000 times during the service life of the gearbox)	T_{2Not}	Nm	26	26	26	26	26		
		in.lb	230	230	230	230	230		
Permitted average input speed ^{d)} (at T_{2N} and 20 °C ambient temperature)	n_{1N}	rpm	3800	4000	4300	4400	4600		
Max. input speed	n_{1Max}	rpm	10000	10000	10000	10000	10000		
Mean no load running torque ^{b)} (at $n_1=3000$ rpm and 20 °C gearbox temperature)	T_{012}	Nm	0.08	0.07	0.05	0.05	0.05		
		in.lb	0.71	0.62	0.44	0.44	0.44		
Max. backlash	j_t	arcmin	≤ 10						
Torsional rigidity ^{b)}	C_{t21}	Nm/arcmin	1.2	1.2	1.2	0.85	0.85		
		in.lb/arcmin	11	11	11	7.5	7.5		
Max. axial force ^{c)}	F_{2AMax}	N	600						
		lb _f	135						
Max. tilting moment	M_{2KMMax}	Nm	17						
		in.lb	150						
Efficiency at full load	η	%	97						
Service life	L_n	h	> 20000						
Weight (incl. standard adapter plate)	m	kg	0.9						
		lb _m	2						
Operating noise (at reference ratio and reference speed – ratio-specific values available in cymex [®])	L_{PA}	dB(A)	≤ 58						
Max. permitted housing temperature		°C	+90						
		°F	+194						
Ambient temperature		°C	-15 to +40						
		°F	+5 to +104						
Lubrication			Lubricated for life						
Direction of rotation			In- and output same direction						
Protection class			IP 64						
Mass moment of inertia (relates to the drive) Clamping hub diameter [mm]	Z	8	J_1	kgcm ²	0.04	0.03	0.03	0.03	0.02
				10 ⁻³ in.lb.s ²	0.04	0.03	0.03	0.03	0.02
	A	9	J_1	kgcm ²	0.04	0.03	0.03	0.03	0.02
				10 ⁻³ in.lb.s ²	0.04	0.03	0.03	0.03	0.02
	B	11	J_1	kgcm ²	0.06	0.05	0.05	0.04	0.04
				10 ⁻³ in.lb.s ²	0.05	0.04	0.04	0.04	0.04
	C	14	J_1	kgcm ²	0.14	0.14	0.13	0.13	0.13
				10 ⁻³ in.lb.s ²	0.12	0.12	0.12	0.12	0.12

Please use our sizing software cymex[®] for a detailed sizing – www.wittenstein-cymex.com

^{a)} Valid for torque transmission only

^{b)} Valid for standard clamping hub diameter

^{c)} Refers to center of the output shaft or flange

^{d)} Please reduce input speed at higher ambient temperatures

1-stage

up to 11⁴⁾ (B)⁵⁾
clamping hub
diameter

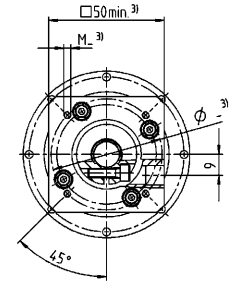
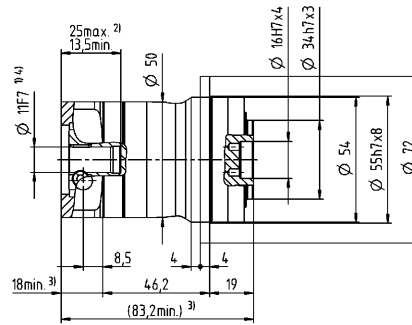
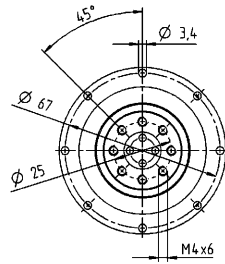

Motor shaft diameter [mm]

up to 14⁴⁾ (C)
clamping hub
diameter

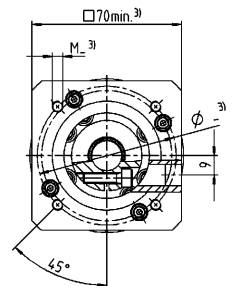
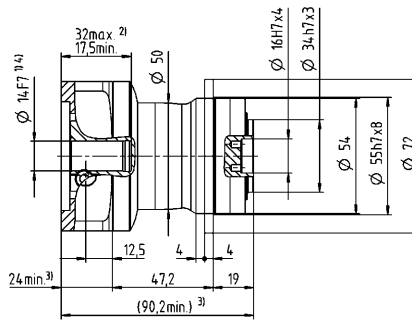
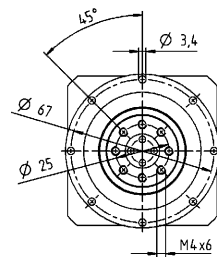

Non-tolerated dimensions are nominal dimensions

¹⁾ Check motor shaft fit

²⁾ Min. / Max. permissible motor shaft length

Longer motor shafts are possible, please contact alpha

³⁾ The dimensions depend on the motor

⁴⁾ Smaller motor shaft diameter is compensated by a bushing with a minimum thickness of 1 mm

⁵⁾ Standard clamping hub diameter

NPT 005 MF 2-stage

			2-stage										
Ratio	i		16	20	25	28	35	40	50	64	70	100	
Max. torque ^{a) b)}	T_{2a}	Nm	18	18	22	18	22	18	22	21	22	21	
		in.lb	159	159	195	159	195	159	195	186	195	186	
Max. acceleration torque (max. 1000 cycles per hour)	T_{2B}	Nm	11	11	14	11	14	11	14	13	14	13	
		in.lb	97	97	124	97	124	97	124	115	124	115	
Emergency stop torque ^{a) b)} (permitted 1000 times during the service life of the gearbox)	T_{2Not}	Nm	26	26	26	26	26	26	26	26	26	26	
		in.lb	230	230	230	230	230	230	230	230	230	230	
Permitted average input speed ^{d)} (at T_{2N} and 20 °C ambient temperature)	n_{1N}	rpm	4000	4000	4000	4300	4300	4600	4600	4400	4600	4600	
Max. input speed	n_{1Max}	rpm	10000	10000	10000	10000	10000	10000	10000	10000	10000	10000	
Mean no load running torque ^{b)} (at $n_1=3000$ rpm and 20 °C gearbox temperature)	T_{012}	Nm	0.04	0.04	0.03	0.03	0.03	0.03	0.03	0.03	0.03	0.03	
		in.lb	0.35	0.35	0.27	0.27	0.27	0.27	0.27	0.27	0.27	0.27	
Max. backlash	j_t	arcmin	≤ 13										
Torsional rigidity ^{b)}	C_{t21}	Nm/arcmin	1.2	1.2	1.2	1.2	1.2	1.2	1.2	0.85	1.2	0.85	
		in.lb/arcmin	11	11	11	11	11	11	11	7.5	11	7.5	
Max. axial force ^{c)}	F_{2AMax}	N	600										
		lb _f	135										
Max. tilting moment	M_{2KMMax}	Nm	17										
		in.lb	150										
Efficiency at full load	η	%	95										
Service life	L_n	h	> 20000										
Weight (incl. standard adapter plate)	m	kg	1.1										
		lb _m	2.4										
Operating noise (at reference ratio and reference speed – ratio-specific values available in cymex®)	L_{PA}	dB(A)	≤ 58										
Max. permitted housing temperature		°C	+90										
		°F	+194										
Ambient temperature		°C	-15 to +40										
		°F	+5 to +104										
Lubrication			Lubricated for life										
Direction of rotation			In- and output same direction										
Protection class			IP 64										
Mass moment of inertia (relates to the drive) Clamping hub diameter [mm]	Z	8	J_1	kgcm ²	0.03	0.03	0.03	0.03	0.03	0.02	0.02	0.02	0.03
				10 ⁻³ in.lb.s ²	0.03	0.03	0.03	0.03	0.03	0.02	0.02	0.02	0.02
	A	9	J_1	kgcm ²	0.03	0.03	0.03	0.03	0.03	0.02	0.02	0.02	0.03
				10 ⁻³ in.lb.s ²	0.03	0.03	0.03	0.03	0.03	0.02	0.02	0.02	0.02
	B	11	J_1	kgcm ²	0.05	0.05	0.04	0.05	0.04	0.04	0.04	0.04	0.05
				10 ⁻³ in.lb.s ²	0.04	0.04	0.04	0.04	0.04	0.04	0.04	0.04	0.04
	C	14	J_1	kgcm ²	0.13	0.13	0.13	0.13	0.13	0.13	0.13	0.13	0.13
				10 ⁻³ in.lb.s ²	0.12	0.12	0.12	0.12	0.12	0.12	0.12	0.12	0.12

Please use our sizing software cymex® for a detailed sizing – www.wittenstein-cymex.com

^{a)} Valid for torque transmission only

^{b)} Valid for standard clamping hub diameter

^{c)} Refers to center of the output shaft or flange

^{d)} Please reduce input speed at higher ambient temperatures

2-stage

Motor shaft diameter [mm]

up to 11⁴⁾ (B)⁵⁾
clamping hub diameter

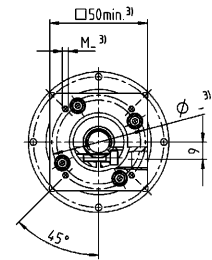
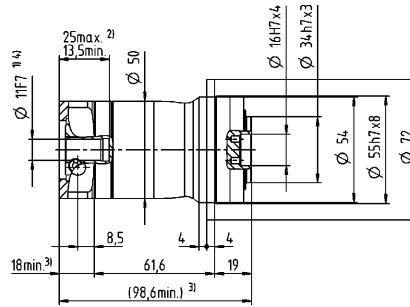
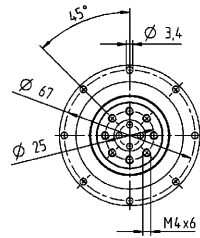

up to 14⁴⁾ (C)
clamping hub diameter

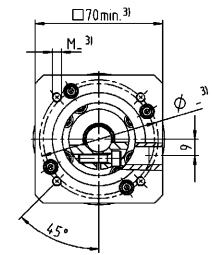
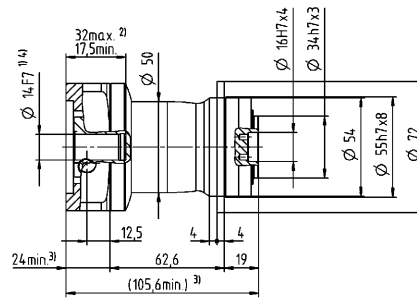
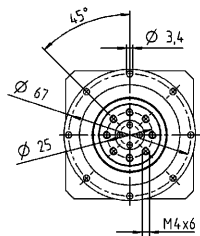

Non-tolerated dimensions are nominal dimensions

¹⁾ Check motor shaft fit

²⁾ Min. / Max. permissible motor shaft length

Longer motor shafts are possible, please contact alpha

³⁾ The dimensions depend on the motor

⁴⁾ Smaller motor shaft diameter is compensated by a bushing with a minimum thickness of 1 mm

⁵⁾ Standard clamping hub diameter

NPT 015 MF 1-stage

			1-stage							
Ratio	i		3	4	5	7	8	10		
Max. torque ^{a) b)}	T_{2a}	Nm	51	56	60	60	56	56		
		in.lb	451	496	531	531	496	496		
Max. acceleration torque (max. 1000 cycles per hour)	T_{2B}	Nm	32	35	40	40	35	35		
		in.lb	283	310	354	354	310	310		
Emergency stop torque ^{a) b)} (permitted 1000 times during the service life of the gearbox)	T_{2Not}	Nm	75	75	75	75	75	75		
		in.lb	664	664	664	664	664	664		
Permitted average input speed ^{d)} (at T_{2N} and 20 °C ambient temperature)	n_{1N}	rpm	3300	3500	3700	4000	4100	4300		
Max. input speed	n_{1Max}	rpm	8000	8000	8000	8000	8000	8000		
Mean no load running torque ^{b)} (at $n_i=3000$ rpm and 20 °C gearbox temperature)	T_{012}	Nm	0.25	0.2	0.17	0.14	0.13	0.11		
		in.lb	2.2	1.8	1.5	1.2	1.2	0.97		
Max. backlash	j_t	arcmin	≤ 8							
Torsional rigidity ^{b)}	C_{t21}	Nm/arcmin	3.3	3.3	3.3	3.3	2.8	2.8		
		in.lb/arcmin	29	29	29	29	25	25		
Max. axial force ^{c)}	F_{2AMax}	N	1380							
		lb _f	311							
Max. tilting moment	M_{2KMMax}	Nm	42							
		in.lb	372							
Efficiency at full load	η	%	97							
Service life	L_n	h	> 20000							
Weight (incl. standard adapter plate)	m	kg	2							
		lb _m	4.4							
Operating noise (at reference ratio and reference speed – ratio-specific values available in cymex®)	L_{PA}	dB(A)	≤ 59							
Max. permitted housing temperature		°C	+90							
		°F	+194							
Ambient temperature		°C	-15 to +40							
		°F	+5 to +104							
Lubrication			Lubricated for life							
Direction of rotation			In- and output same direction							
Protection class			IP 64							
Mass moment of inertia (relates to the drive) Clamping hub diameter [mm]	A	9	J_1	kgcm ²	0.31	0.23	0.19	0.16	0.15	0.14
				10 ⁻³ in.lb.s ²	0.27	0.2	0.17	0.14	0.13	0.12
	B	11	J_1	kgcm ²	0.33	0.24	0.21	0.17	0.17	0.16
				10 ⁻³ in.lb.s ²	0.29	0.21	0.19	0.15	0.15	0.14
	C	14	J_1	kgcm ²	0.41	0.32	0.28	0.25	0.24	0.23
				10 ⁻³ in.lb.s ²	0.36	0.28	0.25	0.22	0.21	0.2
	D	16	J_1	kgcm ²	0.53	0.45	0.41	0.38	0.37	0.36
				10 ⁻³ in.lb.s ²	0.47	0.4	0.36	0.34	0.33	0.32
	E	19	J_1	kgcm ²	0.62	0.53	0.49	0.46	0.45	0.44
				10 ⁻³ in.lb.s ²	0.55	0.47	0.43	0.41	0.4	0.39

Please use our sizing software cymex® for a detailed sizing – www.wittenstein-cymex.com

^{a)} Valid for torque transmission only

^{b)} Valid for standard clamping hub diameter

^{c)} Refers to center of the output shaft or flange

^{d)} Please reduce input speed at higher ambient temperatures

1-stage

Motor shaft diameter [mm]

up to 14⁴⁾ (C)⁵⁾
clamping hub diameter

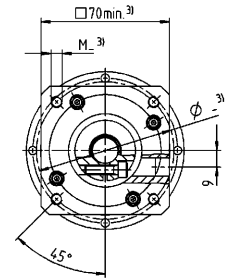
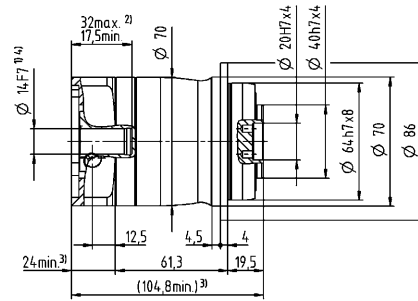
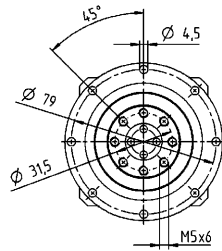

up to 19⁴⁾ (E)
clamping hub diameter

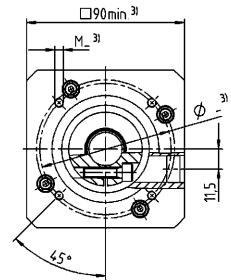
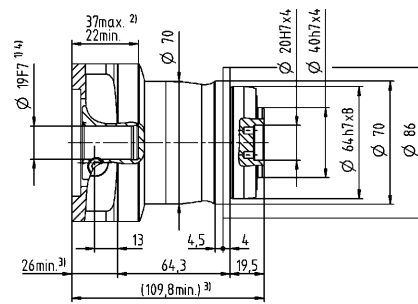
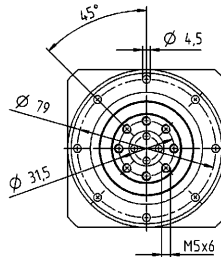

Non-tolerated dimensions are nominal dimensions

¹⁾ Check motor shaft fit

²⁾ Min. / Max. permissible motor shaft length

Longer motor shafts are possible, please contact alpha

³⁾ The dimensions depend on the motor

⁴⁾ Smaller motor shaft diameter is compensated by a bushing with a minimum thickness of 1 mm

⁵⁾ Standard clamping hub diameter

NPT 015 MF 2-stage

			2-stage														
Ratio	i		12	15	16	20	25	28	30	32	35	40	50	64	70	100	
Max. torque ^{a) b)}	T_{2a}	Nm	51	51	56	56	60	56	51	56	60	56	60	56	60	56	
		in.lb	451	451	496	496	531	496	451	496	531	496	531	496	531	496	531
Max. acceleration torque (max. 1000 cycles per hour)	T_{2B}	Nm	32	32	35	35	40	35	32	35	40	35	40	35	40	35	
		in.lb	283	283	310	310	354	310	283	310	354	310	354	310	354	310	
Emergency stop torque ^{a) b)} (permitted 1000 times during the service life of the gearbox)	T_{2Not}	Nm	75	75	75	75	75	75	75	75	75	75	75	75	75	75	
		in.lb	664	664	664	664	664	664	664	664	664	664	664	664	664	664	
Permitted average input speed ^{d)} (at T_{2N} and 20 °C ambient temperature)	n_{1N}	rpm	3800	4000	3800	4000	4000	4300	4600	4400	4300	4600	4600	4400	4600	4600	
Max. input speed	n_{1Max}	rpm	10000	10000	10000	10000	10000	10000	10000	10000	10000	10000	10000	10000	10000	10000	
Mean no load running torque ^{b)} (at $n_1=3000$ rpm and 20 °C gearbox temperature)	T_{012}	Nm	0.08	0.07	0.06	0.06	0.05	0.05	0.05	0.04	0.04	0.04	0.04	0.03	0.03	0.03	
		in.lb	0.71	0.62	0.53	0.53	0.44	0.44	0.44	0.35	0.35	0.35	0.35	0.35	0.27	0.27	
Max. backlash	j_t	arcmin	≤ 10														
Torsional rigidity ^{b)}	C_{t21}	Nm/arcmin	3.3	3.3	3.3	3.3	3.3	3.3	3.3	3.3	3.3	3.3	3.3	2.8	3.3	2.8	
		in.lb/arcmin	29	29	29	29	29	29	29	29	29	29	29	29	25	29	25
Max. axial force ^{c)}	F_{2AMax}	N	1380														
		lb _f	311														
Max. tilting moment	M_{2KMMax}	Nm	42														
		in.lb	372														
Efficiency at full load	η	%	95														
Service life	L_n	h	> 20000														
Weight (incl. standard adapter plate)	m	kg	2.1														
		lb _m	4.6														
Operating noise (at reference ratio and reference speed – ratio-specific values available in cymex®)	L_{PA}	dB(A)	≤ 58														
Max. permitted housing temperature		°C	+90														
		°F	+194														
Ambient temperature		°C	-15 to +40														
		°F	+5 to +104														
Lubrication			Lubricated for life														
Direction of rotation			In- and output same direction														
Protection class			IP 64														
Mass moment of inertia (relates to the drive) Clamping hub diameter [mm]	Z	8	J_1	kgcm ²	0.04	0.04	0.03	0.03	0.03	0.03	0.03	0.03	0.03	0.03	0.02	0.02	0.02
				10 ⁻³ in.lb.s ²	0.04	0.04	0.03	0.03	0.03	0.03	0.03	0.03	0.03	0.03	0.03	0.03	0.02
	A	9	J_1	kgcm ²	0.04	0.04	0.03	0.03	0.03	0.03	0.03	0.03	0.03	0.03	0.02	0.02	0.02
				10 ⁻³ in.lb.s ²	0.04	0.04	0.03	0.03	0.03	0.03	0.03	0.03	0.03	0.03	0.03	0.03	0.02
	B	11	J_1	kgcm ²	0.06	0.06	0.05	0.05	0.05	0.05	0.05	0.05	0.05	0.04	0.04	0.04	0.04
				10 ⁻³ in.lb.s ²	0.05	0.05	0.04	0.04	0.04	0.04	0.04	0.04	0.04	0.04	0.04	0.04	0.04
	C	14	J_1	kgcm ²	0.15	0.14	0.14	0.14	0.13	0.13	0.14	0.13	0.13	0.13	0.13	0.13	0.13
				10 ⁻³ in.lb.s ²	0.13	0.12	0.12	0.12	0.12	0.12	0.12	0.12	0.12	0.12	0.12	0.12	0.12

Please use our sizing software cymex® for a detailed sizing – www.wittenstein-cymex.com

^{a)} Valid for torque transmission only

^{b)} Valid for standard clamping hub diameter

^{c)} Refers to center of the output shaft or flange

^{d)} Please reduce input speed at higher ambient temperatures

2-stage

up to 11⁴⁾ (B)⁵⁾
clamping hub
diameter

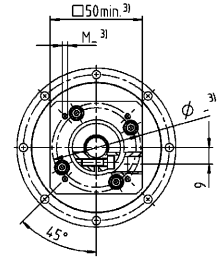
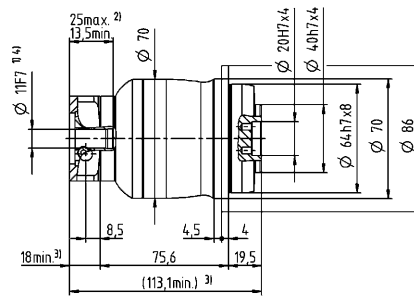
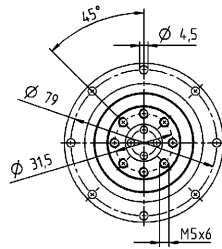

Motor shaft diameter [mm]

up to 14⁴⁾ (C)
clamping hub
diameter

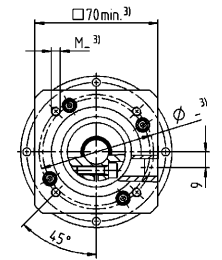
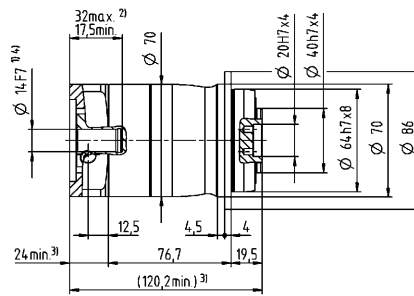
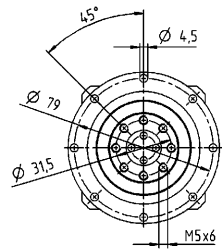

Non-tolerated dimensions are nominal dimensions

¹⁾ Check motor shaft fit

²⁾ Min. / Max. permissible motor shaft length

Longer motor shafts are possible, please contact alpha

³⁾ The dimensions depend on the motor

⁴⁾ Smaller motor shaft diameter is compensated by a bushing with a minimum thickness of 1 mm

⁵⁾ Standard clamping hub diameter

NPT 025 MF 1-stage

			1-stage							
Ratio	i		3	4	5	7	8	10		
Max. torque ^{a) b)}	T_{2a}	Nm	128	152	160	160	144	144		
		in.lb	1133	1345	1416	1416	1275	1275		
Max. acceleration torque (max. 1000 cycles per hour)	T_{2B}	Nm	80	95	100	100	90	90		
		in.lb	708	841	885	885	797	797		
Emergency stop torque ^{a) b)} (permitted 1000 times during the service life of the gearbox)	T_{2Not}	Nm	190	190	190	190	190	190		
		in.lb	1682	1682	1682	1682	1682	1682		
Permitted average input speed ^{d)} (at T_{2N} and 20 °C ambient temperature)	n_{1N}	rpm	3100	3300	3400	3600	3700	3900		
Max. input speed	n_{1Max}	rpm	7000	7000	7000	7000	7000	7000		
Mean no load running torque ^{b)} (at $n_1=3000$ rpm and 20 °C gearbox temperature)	T_{012}	Nm	0.43	0.35	0.3	0.24	0.23	0.2		
		in.lb	3.8	3.1	2.7	2.1	2	1.8		
Max. backlash	j_t	arcmin	≤ 8							
Torsional rigidity ^{b)}	C_{t21}	Nm/arcmin	9.5	9.5	9.5	9.5	8.5	8.5		
		in.lb/arcmin	84	84	84	84	75	75		
Max. axial force ^{c)}	F_{2AMax}	N	1900							
		lb _f	428							
Max. tilting moment	M_{2KMMax}	Nm	79							
		in.lb	699							
Efficiency at full load	η	%	97							
Service life	L_n	h	> 20000							
Weight (incl. standard adapter plate)	m	kg	4.4							
		lb _m	9.7							
Operating noise (at reference ratio and reference speed – ratio-specific values available in cymex [®])	L_{PA}	dB(A)	≤ 61							
Max. permitted housing temperature		°C	+90							
		°F	+194							
Ambient temperature		°C	-15 to +40							
		°F	+5 to +104							
Lubrication			Lubricated for life							
Direction of rotation			In- and output same direction							
Protection class			IP 64							
Mass moment of inertia (relates to the drive) Clamping hub diameter [mm]	C	14	J_1	kgcm ²	0.75	0.57	0.44	0.33	0.3	0.27
				10 ⁻³ in.lb.s ²	0.66	0.5	0.39	0.29	0.27	0.24
	D	16	J_1	kgcm ²	0.9	0.72	0.59	0.46	0.45	0.42
				10 ⁻³ in.lb.s ²	0.8	0.64	0.52	0.41	0.4	0.37
	E	19	J_1	kgcm ²	0.99	0.8	0.67	0.56	0.53	0.5
				10 ⁻³ in.lb.s ²	0.88	0.71	0.59	0.5	0.47	0.44
	G	24	J_1	kgcm ²	2	1.8	1.7	1.6	1.6	1.5
				10 ⁻³ in.lb.s ²	1.8	1.6	1.5	1.4	1.4	1.3
	H	28	J_1	kgcm ²	1.7	1.5	1.4	1.3	1.3	1.2
				10 ⁻³ in.lb.s ²	1.5	1.3	1.2	1.2	1.2	1.1

Please use our sizing software cymex[®] for a detailed sizing – www.wittenstein-cymex.com

^{a)} Valid for torque transmission only

^{b)} Valid for standard clamping hub diameter

^{c)} Refers to center of the output shaft or flange

^{d)} Please reduce input speed at higher ambient temperatures

1-stage

up to 19⁴⁾ (E)⁵⁾
clamping hub
diameter

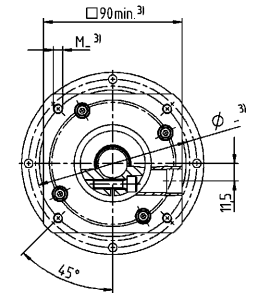
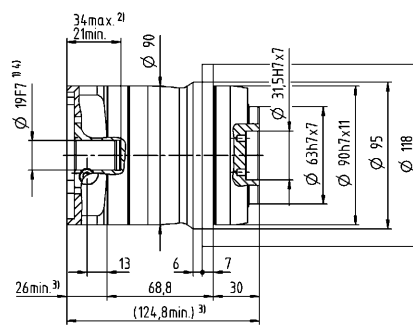
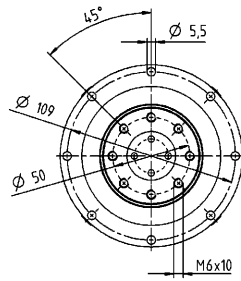

Motor shaft diameter [mm]

up to 28⁴⁾ (H)
clamping hub
diameter

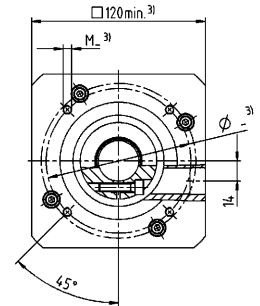
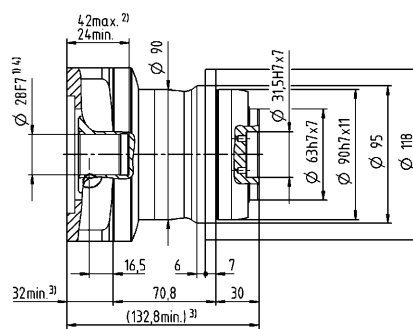
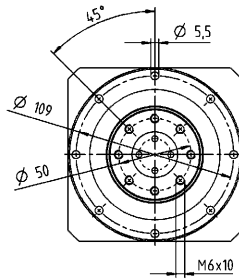

Non-tolerated dimensions are nominal dimensions

¹⁾ Check motor shaft fit

²⁾ Min. / Max. permissible motor shaft length

Longer motor shafts are possible, please contact alpha

³⁾ The dimensions depend on the motor

⁴⁾ Smaller motor shaft diameter is compensated

by a bushing with a minimum thickness of 1 mm

⁵⁾ Standard clamping hub diameter

NPT 025 MF 2-stage

			2-stage															
Ratio	i		9	12	15	16	20	25	28	30	32	35	40	50	64	70	100	
Max. torque ^{a) b)}	T_{2a}	Nm	128	128	128	152	152	160	152	128	152	160	152	160	144	160	144	
		in.lb	1133	1133	1133	1345	1345	1416	1345	1133	1345	1416	1345	1416	1275	1416	1275	
Max. acceleration torque (max. 1000 cycles per hour)	T_{2B}	Nm	80	80	80	95	95	100	95	80	95	100	95	100	90	100	90	
		in.lb	708	708	708	841	841	885	841	708	841	885	841	885	797	885	797	
Emergency stop torque ^{a) b)} (permitted 1000 times during the service life of the gearbox)	T_{2Not}	Nm	190	190	190	190	190	190	190	190	190	190	190	190	190	190	190	
		in.lb	1682	1682	1682	1682	1682	1682	1682	1682	1682	1682	1682	1682	1682	1682	1682	
Permitted average input speed ^{d)} (at T_{2N} and 20 °C ambient temperature)	n_{1N}	rpm	3300	3500	3700	3500	3700	3700	4000	4300	4100	4000	4300	4300	4100	4300	4300	
Max. input speed	n_{1Max}	rpm	8000	8000	8000	8000	8000	8000	8000	8000	8000	8000	8000	8000	8000	8000	8000	
Mean no load running torque ^{b)} (at $n_1=3000$ rpm and 20 °C gearbox temperature)	T_{012}	Nm	0.16	0.13	0.12	0.11	0.1	0.09	0.09	0.08	0.08	0.08	0.08	0.07	0.07	0.06	0.06	
		in.lb	1.4	1.2	1.1	0.97	0.89	0.8	0.8	0.71	0.71	0.71	0.71	0.62	0.62	0.53	0.53	
Max. backlash	j_t	arcmin	≤ 10															
Torsional rigidity ^{b)}	C_{t21}	Nm/arcmin	10	10	10	10	10	9.5	10	10	10	9.5	10	9.5	8.5	9.5	8.5	
		in.lb/arcmin	89	89	89	89	89	84	89	89	89	84	89	84	75	84	75	
Max. axial force ^{c)}	F_{2AMax}	N	1900															
		lb _f	428															
Max. tilting moment	M_{2KMMax}	Nm	79															
		in.lb	699															
Efficiency at full load	η	%	95															
Service life	L_n	h	> 20000															
Weight (incl. standard adapter plate)	m	kg	4.7															
		lb _m	10															
Operating noise (at reference ratio and reference speed – ratio-specific values available in cymex®)	L_{PA}	dB(A)	≤ 59															
Max. permitted housing temperature		°C	+90															
		°F	+194															
Ambient temperature		°C	-15 to +40															
		°F	+5 to +104															
Lubrication			Lubricated for life															
Direction of rotation			In- and output same direction															
Protection class			IP 64															
Mass moment of inertia (relates to the drive) Clamping hub diameter [mm]	A	9	J_1	kgcm ²	0.28	0.23	0.22	0.22	0.21	0.2	0.2	0.19	0.19	0.19	0.19	0.19	0.19	0.19
				10 ⁻³ in.lb.s ²	0.25	0.2	0.19	0.19	0.19	0.18	0.18	0.17	0.17	0.17	0.17	0.17	0.17	0.17
	B	11	J_1	kgcm ²	0.3	0.25	0.23	0.24	0.23	0.22	0.21	0.21	0.21	0.21	0.21	0.21	0.21	0.21
				10 ⁻³ in.lb.s ²	0.27	0.22	0.2	0.21	0.2	0.19	0.19	0.19	0.19	0.19	0.19	0.19	0.19	0.19
	C	14	J_1	kgcm ²	0.37	0.32	0.31	0.31	0.3	0.29	0.29	0.29	0.29	0.29	0.28	0.28	0.28	0.28
				10 ⁻³ in.lb.s ²	0.33	0.28	0.27	0.27	0.27	0.26	0.26	0.26	0.26	0.26	0.25	0.25	0.25	0.25
	D	16	J_1	kgcm ²	0.5	0.45	0.44	0.44	0.43	0.42	0.42	0.41	0.41	0.41	0.41	0.41	0.41	0.41
				10 ⁻³ in.lb.s ²	0.44	0.4	0.39	0.39	0.38	0.37	0.37	0.36	0.36	0.36	0.36	0.36	0.36	0.36
	E	19	J_1	kgcm ²	0.58	0.53	0.52	0.52	0.51	0.51	0.5	0.5	0.5	0.5	0.49	0.49	0.49	0.49
				10 ⁻³ in.lb.s ²	0.51	0.47	0.46	0.46	0.45	0.45	0.44	0.44	0.44	0.44	0.43	0.43	0.43	0.43

Please use our sizing software cymex® for a detailed sizing – www.wittenstein-cymex.com

^{a)} Valid for torque transmission only

^{b)} Valid for standard clamping hub diameter

^{c)} Refers to center of the output shaft or flange

^{d)} Please reduce input speed at higher ambient temperatures

2-stage

up to 14⁴⁾ (C)⁵⁾
clamping hub
diameter

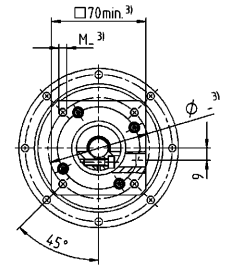
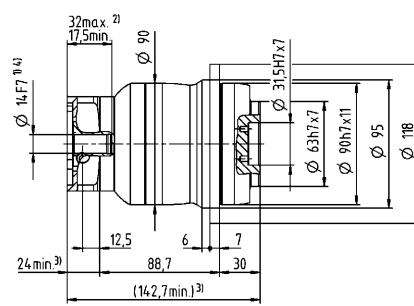
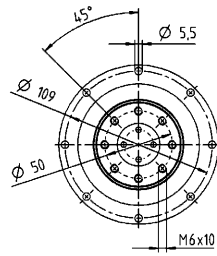

Motor shaft diameter [mm]

up to 19⁴⁾ (E)
clamping hub
diameter

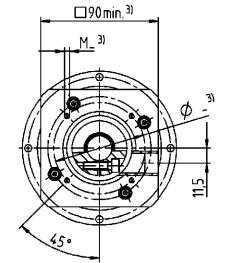
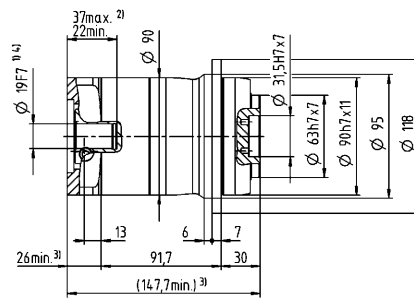
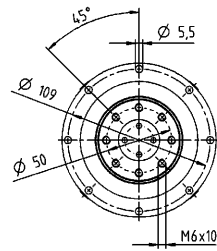

Non-tolerated dimensions are nominal dimensions

¹⁾ Check motor shaft fit

²⁾ Min. / Max. permissible motor shaft length

Longer motor shafts are possible, please contact alpha

³⁾ The dimensions depend on the motor

⁴⁾ Smaller motor shaft diameter is compensated by a bushing with a minimum thickness of 1 mm

⁵⁾ Standard clamping hub diameter

NPT 035 MF 1-stage

			1-stage							
Ratio	i		3	4	5	7	8	10		
Max. torque ^{a) b)}	T_{2a}	Nm	320	365	365	365	352	352		
		in.lb	2832	3231	3231	3231	3115	3115		
Max. acceleration torque (max. 1000 cycles per hour)	T_{2B}	Nm	200	255	250	250	220	220		
		in.lb	1770	2257	2213	2213	1947	1947		
Emergency stop torque ^{a) b)} (permitted 1000 times during the service life of the gearbox)	T_{2Not}	Nm	480	480	480	480	480	480		
		in.lb	4248	4248	4248	4248	4248	4248		
Permitted average input speed ^{d)} (at T_{2N} and 20 °C ambient temperature)	n_{1N}	rpm	2300	2500	2600	2800	2900	3000		
Max. input speed	n_{1Max}	rpm	6000	6000	6000	6000	6000	6000		
Mean no load running torque ^{b)} (at $n_1=3000$ rpm and 20 °C gearbox temperature)	T_{012}	Nm	1.7	1.3	1.1	0.79	0.71	0.6		
		in.lb	15	12	9.7	7	6.3	5.3		
Max. backlash	j_t	arcmin	≤ 8							
Torsional rigidity ^{b)}	C_{t21}	Nm/arcmin	25	25	25	25	22	22		
		in.lb/arcmin	221	221	221	221	195	195		
Max. axial force ^{c)}	F_{2AMax}	N	3500							
		lb _f	788							
Max. tilting moment	M_{2KMMax}	Nm	134							
		in.lb	1186							
Efficiency at full load	η	%	97							
Service life	L_n	h	> 20000							
Weight (incl. standard adapter plate)	m	kg	9.4							
		lb _m	21							
Operating noise (at reference ratio and reference speed – ratio-specific values available in cymex [®])	L_{PA}	dB(A)	≤ 65							
Max. permitted housing temperature		°C	+90							
		°F	+194							
Ambient temperature		°C	-15 to +40							
		°F	+5 to +104							
Lubrication			Lubricated for life							
Direction of rotation			In- and output same direction							
Protection class			IP 64							
Mass moment of inertia (relates to the drive) Clamping hub diameter [mm]	E	19	J_1	kgcm ²	3.2	2	1.6	1.2	1	0.93
				10 ⁻³ in.lb.s ²	2.8	1.8	1.4	1.1	0.89	0.82
	G	24	J_1	kgcm ²	4	2.8	2.4	1.9	1.8	1.7
				10 ⁻³ in.lb.s ²	3.5	2.5	2.1	1.7	1.6	1.5
	H	28	J_1	kgcm ²	3.7	2.5	2.1	1.6	1.5	1.4
				10 ⁻³ in.lb.s ²	3.3	2.2	1.9	1.4	1.3	1.2
	I	32	J_1	kgcm ²	7.7	6.6	6.1	5.7	5.6	5.5
				10 ⁻³ in.lb.s ²	6.8	5.8	5.4	5	5	4.9
	K	38	J_1	kgcm ²	8.9	7.8	7.3	6.9	6.7	6.6
				10 ⁻³ in.lb.s ²	7.9	6.9	6.5	6.1	5.9	5.8

Please use our sizing software cymex[®] for a detailed sizing – www.wittenstein-cymex.com

^{a)} Valid for torque transmission only

^{b)} Valid for standard clamping hub diameter

^{c)} Refers to center of the output shaft or flange

^{d)} Please reduce input speed at higher ambient temperatures

1-stage

up to 24/28⁴⁾
(G⁵⁾/H)
clamping hub
diameter

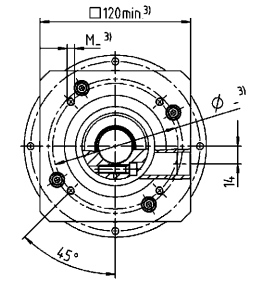
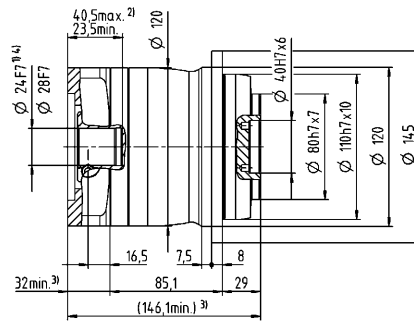
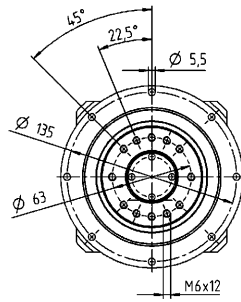

Motor shaft diameter [mm]

up to 38⁴⁾ (K)
clamping hub
diameter

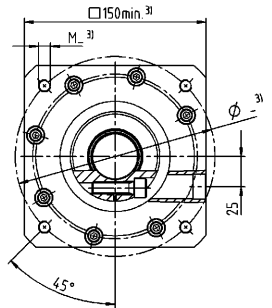
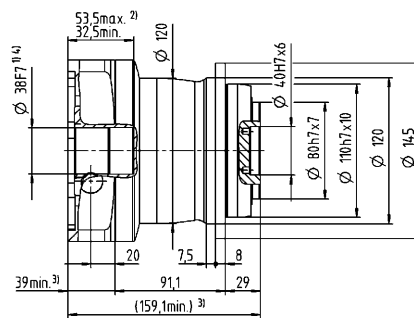
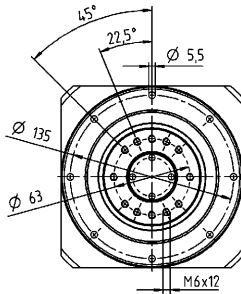

Non-tolerated dimensions are nominal dimensions

¹⁾ Check motor shaft fit

²⁾ Min. / Max. permissible motor shaft length

Longer motor shafts are possible, please contact alpha

³⁾ The dimensions depend on the motor

⁴⁾ Smaller motor shaft diameter is compensated

by a bushing with a minimum thickness of 1 mm

⁵⁾ Standard clamping hub diameter

NPT 035 MF 2-stage

			2-stage																
Ratio	i		9	12	15	16	20	25	28	30	32	35	40	50	64	70	100		
Max. torque ^{a) b)}	T_{2a}	Nm	320	320	320	365	365	365	365	320	365	365	365	365	352	365	352		
		in.lb	2832	2832	2832	3231	3231	3231	3231	2832	3231	3231	3231	3231	3115	3231	3115		
Max. acceleration torque (max. 1000 cycles per hour)	T_{2B}	Nm	200	200	200	255	255	250	255	200	255	250	255	250	220	250	220		
		in.lb	1770	1770	1770	2257	2257	2213	2257	1770	2257	2213	2257	2213	1947	2213	1947		
Emergency stop torque ^{a) b)} (permitted 1000 times during the service life of the gearbox)	T_{2Not}	Nm	480	480	480	480	480	480	480	480	480	480	480	480	480	480	480		
		in.lb	4248	4248	4248	4248	4248	4248	4248	4248	4248	4248	4248	4248	4248	4248	4248		
Permitted average input speed ^{d)} (at T_{2N} and 20 °C ambient temperature)	n_{1N}	rpm	3100	3300	3400	3300	3400	3400	3600	3900	3700	3600	3900	3900	3700	3900	3900		
Max. input speed	n_{1Max}	rpm	7000	7000	7000	7000	7000	7000	7000	7000	7000	7000	7000	7000	7000	7000	7000		
Mean no load running torque ^{b)} (at $n_1=3000$ rpm and 20 °C gearbox temperature)	T_{012}	Nm	0.6	0.48	0.4	0.38	0.33	0.28	0.26	0.25	0.24	0.23	0.21	0.19	0.17	0.16	0.15		
		in.lb	5.3	4.2	3.5	3.4	2.9	2.5	2.3	2.2	2.1	2	1.9	1.7	1.5	1.4	1.3		
Max. backlash	j_t	arcmin	≤ 10																
Torsional rigidity ^{b)}	C_{t21}	Nm/arcmin	25	25	25	25	25	25	25	25	25	25	25	25	22	25	22		
		in.lb/arcmin	221	221	221	221	221	221	221	221	221	221	221	221	195	221	195		
Max. axial force ^{c)}	F_{2AMax}	N	3500																
		lb _f	788																
Max. tilting moment	M_{2KMMax}	Nm	134																
		in.lb	1186																
Efficiency at full load	η	%	95																
Service life	L_n	h	> 20000																
Weight (incl. standard adapter plate)	m	kg	9.8																
		lb _m	22																
Operating noise (at reference ratio and reference speed – ratio-specific values available in cymex®)	L_{PA}	dB(A)	≤ 61																
Max. permitted housing temperature		°C	+90																
		°F	+194																
Ambient temperature		°C	-15 to +40																
		°F	+5 to +104																
Lubrication			Lubricated for life																
Direction of rotation			In- and output same direction																
Protection class			IP 64																
Mass moment of inertia (relates to the drive) Clamping hub diameter [mm]	C	14	J_1	kgcm ²	0.68	0.63	0.62	0.45	0.44	0.37	0.38	0.52	0.38	0.32	0.37	0.31	0.26	0.27	0.24
				10 ⁻³ in.lb.s ²	0.6	0.56	0.55	0.4	0.39	0.33	0.34	0.46	0.34	0.28	0.33	0.27	0.23	0.24	0.21
	D	16	J_1	kgcm ²	0.82	0.78	0.77	0.6	0.58	0.51	0.51	0.67	0.53	0.45	0.52	0.46	0.4	0.41	0.39
				10 ⁻³ in.lb.s ²	0.73	0.69	0.68	0.53	0.51	0.45	0.45	0.59	0.47	0.4	0.46	0.41	0.35	0.36	0.35
	E	19	J_1	kgcm ²	0.91	0.87	0.86	0.69	0.67	0.6	0.61	0.76	0.61	0.55	0.6	0.55	0.49	0.5	0.48
				10 ⁻³ in.lb.s ²	0.81	0.77	0.76	0.61	0.59	0.53	0.54	0.67	0.54	0.49	0.53	0.49	0.43	0.44	0.42
	G	24	J_1	kgcm ²	1.9	1.9	1.9	1.7	1.7	1.6	1.6	1.8	1.7	1.6	1.6	1.6	1.5	1.5	1.5
				10 ⁻³ in.lb.s ²	1.7	1.7	1.7	1.5	1.5	1.4	1.4	1.6	1.5	1.4	1.4	1.4	1.3	1.3	1.3
	H	28	J_1	kgcm ²	1.7	1.6	1.6	1.4	1.4	1.3	1.4	1.5	1.4	1.3	1.3	1.3	1.2	1.2	1.2
				10 ⁻³ in.lb.s ²	1.5	1.4	1.4	1.2	1.2	1.2	1.2	1.3	1.2	1.2	1.2	1.2	1.1	1.1	1.1

Please use our sizing software cymex® for a detailed sizing – www.wittenstein-cymex.com

^{a)} Valid for torque transmission only

^{b)} Valid for standard clamping hub diameter

^{c)} Refers to center of the output shaft or flange

^{d)} Please reduce input speed at higher ambient temperatures

2-stage

up to 19⁴⁾ (E)⁵⁾
clamping hub
diameter

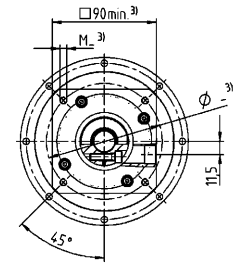
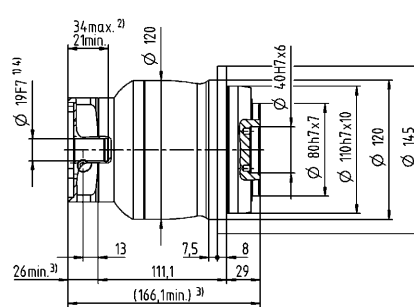
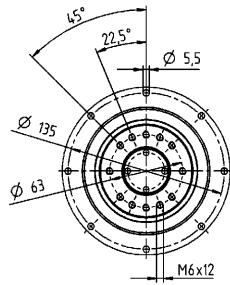

Motor shaft diameter [mm]

up to 28⁴⁾ (H)
clamping hub
diameter

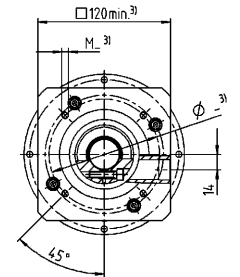
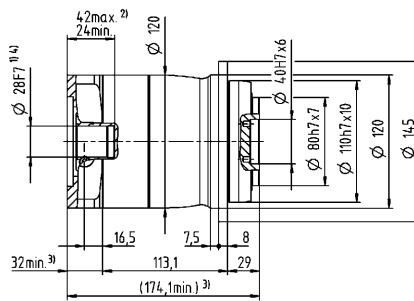
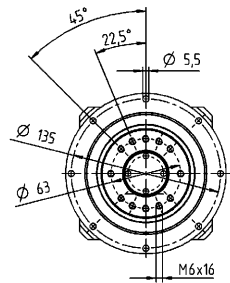

Non-tolerated dimensions are nominal dimensions

¹⁾ Check motor shaft fit

²⁾ Min. / Max. permissible motor shaft length

Longer motor shafts are possible, please contact alpha

³⁾ The dimensions depend on the motor

⁴⁾ Smaller motor shaft diameter is compensated

by a bushing with a minimum thickness of 1 mm

⁵⁾ Standard clamping hub diameter

NPT 045 MF 1-/2-stage

			1-stage			2-stage						
Ratio	i		5	8	10	25	32	50	64	100		
Max. torque ^{a) b)}	T_{2a}	Nm	700	640	640	700	640	700	640	640		
		in.lb	6196	5665	5665	6196	5665	6196	5665	5665		
Max. acceleration torque (max. 1000 cycles per hour)	T_{2B}	Nm	500	400	400	500	400	500	400	400		
		in.lb	4425	3540	3540	4425	3540	4425	3540	3540		
Emergency stop torque ^{a) b)} (permitted 1000 times during the service life of the gearbox)	T_{2Not}	Nm	1000	1000	1000	1000	1000	1000	1000	1000		
		in.lb	8851	8851	8851	8851	8851	8851	8851	8851		
Permitted average input speed ^{d)} (at T_{2N} and 20 °C ambient temperature)	n_{1N}	rpm	2000	2200	2300	2600	2500	3000	2900	3000		
Max. input speed	n_{1Max}	rpm	4000	4000	4000	6000	6000	6000	6000	6000		
Mean no load running torque ^{b)} (at $n_i=3000$ rpm and 20 °C gearbox temperature)	T_{012}	Nm	1.5	1.1	0.9	0.39	0.34	0.27	0.24	0.21		
		in.lb	13	9.7	8	3.5	3	2.4	2.1	1.9		
Max. backlash	j_t	arcmin	≤ 8			≤ 10						
Torsional rigidity ^{b)}	C_{t21}	Nm/arcmin	55	44	44	55	44	55	44	44		
		in.lb/arcmin	487	389	389	487	389	487	389	389		
Max. axial force ^{c)}	F_{2AMax}	N	3800			3800						
		lb _f	855			855						
Max. tilting moment	M_{2KMax}	Nm	256			256						
		in.lb	2266			2266						
Efficiency at full load	η	%	97			95						
Service life	L_n	h	> 20000			> 20000						
Weight (incl. standard adapter plate)	m	kg	19			20						
		lb _m	42			44						
Operating noise (at reference ratio and reference speed – ratio-specific values available in cymex [®])	L_{PA}	dB(A)	≤ 68			≤ 65						
Max. permitted housing temperature		°C	+90			+90						
		°F	+194			+194						
Ambient temperature		°C	-15 to +40			-15 to +40						
		°F	+5 to +104			+5 to +104						
Lubrication			Lubricated for life									
Direction of rotation			In- and output same direction									
Protection class			IP 64									
Mass moment of inertia (relates to the drive) Clamping hub diameter [mm]	E	19	J_1	kgcm ²	-	-	-	1.3	1.1	1.1	0.88	0.83
				10 ⁻³ in.lb.s ²	-	-	-	1.2	0.97	0.97	0.78	0.73
	G	24	J_1	kgcm ²	-	-	-	2	1.9	1.8	1.7	1.6
				10 ⁻³ in.lb.s ²	-	-	-	1.8	1.7	1.6	1.5	1.4
	H	28	J_1	kgcm ²	-	-	-	1.8	1.6	1.6	1.4	1.3
				10 ⁻³ in.lb.s ²	-	-	-	1.6	1.4	1.4	1.2	1.2
	I	32	J_1	kgcm ²	-	-	-	5.8	5.7	5.6	5.4	5.4
				10 ⁻³ in.lb.s ²	-	-	-	5.1	5	5	4.8	4.8
	K	38	J_1	kgcm ²	9.8	7.8	7.4	7	6.9	6.8	6.6	6.5
				10 ⁻³ in.lb.s ²	8.7	6.9	6.5	6.2	6.1	6	5.8	5.8

Please use our sizing software cymex[®] for a detailed sizing – www.wittenstein-cymex.com

^{a)} Valid for torque transmission only

^{b)} Valid for standard clamping hub diameter

^{c)} Refers to center of the output shaft or flange

^{d)} Please reduce input speed at higher ambient temperatures

1-stage

up to 38⁴⁾ (K)⁵⁾
clamping hub diameter

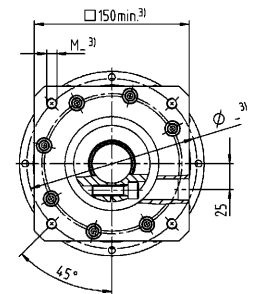
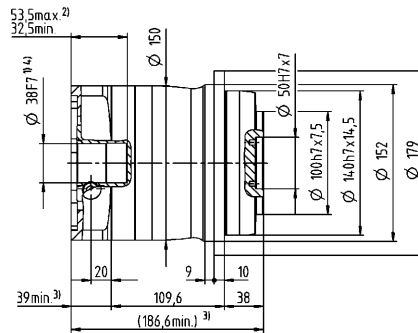
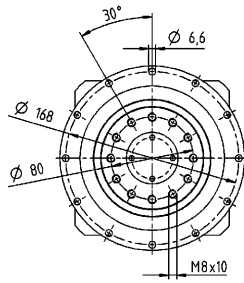

2-stage

up to 28⁴⁾ (H)⁵⁾
clamping hub diameter

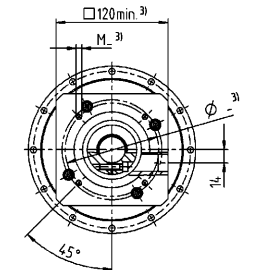
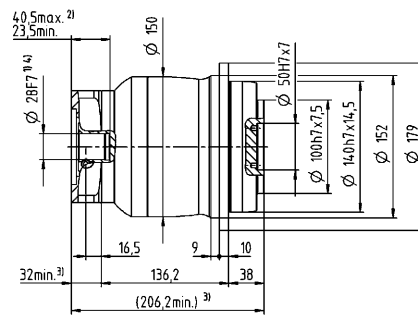
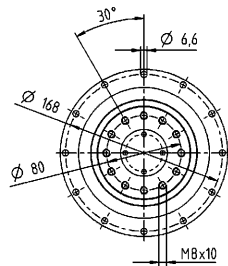

Motor shaft diameter [mm]

up to 38⁴⁾ (K)
clamping hub diameter

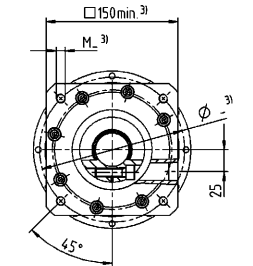
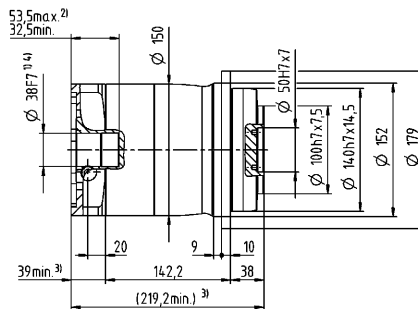
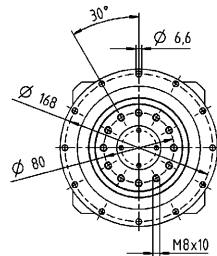

Non-tolerated dimensions are nominal dimensions

¹⁾ Check motor shaft fit

²⁾ Min. / Max. permissible motor shaft length

Longer motor shafts are possible, please contact alpha

³⁾ The dimensions depend on the motor

⁴⁾ Smaller motor shaft diameter is compensated by a bushing with a minimum thickness of 1 mm

⁵⁾ Standard clamping hub diameter

NPT 015 MA 1-/2-stage

			1-stage		2-stage							
Ratio	i		3	4	12	15	16	20	28	30	40	
Max. torque ^{a) b)}	T_{2a}	Nm	62	62	62	62	62	62	62	62	62	
		in.lb	549	549	549	549	549	549	549	549	549	
Max. acceleration torque (max. 1000 cycles per hour)	T_{2B}	Nm	55	42	39	42	42	42	42	39	42	
		in.lb	487	372	345	372	372	372	372	345	372	
Emergency stop torque ^{a) b)} (permitted 1000 times during the service life of the gearbox)	T_{2Not}	Nm	75	75	75	75	75	75	75	75	75	
		in.lb	664	664	664	664	664	664	664	664	664	
Permitted average input speed ^{d)} (at T_{2N} and 20 °C ambient temperature)	n_{1N}	rpm	3300	3500	3800	4000	3800	4000	4300	4600	4600	
Max. input speed	n_{1Max}	rpm	8000	8000	10000	10000	10000	10000	10000	10000	10000	
Mean no load running torque ^{b)} (at $n_1=3000$ rpm and 20 °C gearbox temperature)	T_{012}	Nm	0.25	0.2	0.08	0.07	0.06	0.06	0.05	0.05	0.04	
		in.lb	2.2	1.8	0.71	0.62	0.53	0.53	0.44	0.44	0.35	
Max. backlash	j_t	arcmin	≤ 8		≤ 10							
Torsional rigidity ^{b)}	C_{t21}	Nm/arcmin	4	4	4	4	4	4	4	4	4	
		in.lb/arcmin	35	35	35	35	35	35	35	35	35	
Max. axial force ^{c)}	F_{2AMax}	N	1380		1380							
		lb _f	311		311							
Max. tilting moment	M_{2KMMax}	Nm	42		42							
		in.lb	372		372							
Efficiency at full load	η	%	97		95							
Service life	L_n	h	> 20000		> 20000							
Weight (incl. standard adapter plate)	m	kg	2		2.1							
		lb _m	4.4		4.6							
Operating noise (at reference ratio and reference speed – ratio-specific values available in cymex®)	L_{PA}	dB(A)	≤ 59		≤ 58							
Max. permitted housing temperature		°C	+90		+90							
		°F	+194		+194							
Ambient temperature		°C	-15 to +40		-15 to +40							
		°F	+5 to +104		+5 to +104							
Lubrication			Lubricated for life									
Direction of rotation			In- and output same direction									
Protection class			IP 64									
Mass moment of inertia (relates to the drive) Clamping hub diameter [mm]	Z	8	J_1	kgcm ²	-	-	0.04	0.04	0.03	0.03	0.03	0.03
				10 ⁻³ in.lb.s ²	-	-	0.04	0.04	0.03	0.03	0.03	0.03
	A	9	J_1	kgcm ²	0.31	0.23	0.04	0.04	0.03	0.03	0.03	0.03
				10 ⁻³ in.lb.s ²	0.27	0.2	0.04	0.04	0.03	0.03	0.03	0.03
	B	11	J_1	kgcm ²	0.33	0.24	0.06	0.06	0.05	0.05	0.05	0.05
				10 ⁻³ in.lb.s ²	0.29	0.21	0.05	0.05	0.04	0.04	0.04	0.04
	C	14	J_1	kgcm ²	0.41	0.32	0.15	0.14	0.14	0.14	0.13	0.14
				10 ⁻³ in.lb.s ²	0.36	0.28	0.13	0.12	0.12	0.12	0.12	0.12
	D	16	J_1	kgcm ²	0.53	0.45	-	-	-	-	-	-
				10 ⁻³ in.lb.s ²	0.47	0.4	-	-	-	-	-	-
	E	19	J_1	kgcm ²	0.62	0.53	-	-	-	-	-	-
				10 ⁻³ in.lb.s ²	0.55	0.47	-	-	-	-	-	-

Please use our sizing software cymex® for a detailed sizing – www.wittenstein-cymex.com

^{a)} Valid for torque transmission only

^{b)} Valid for standard clamping hub diameter

^{c)} Refers to center of the output shaft or flange

^{d)} Please reduce input speed at higher ambient temperatures

1-stage

up to 14⁴⁾ (C)⁵⁾
clamping hub diameter

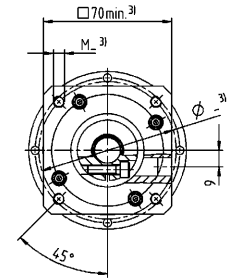
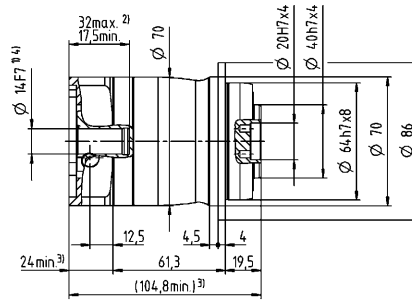
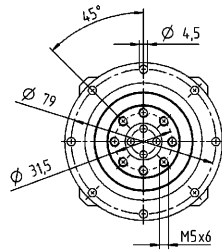

up to 19⁴⁾ (E)
clamping hub diameter

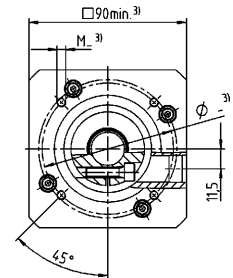
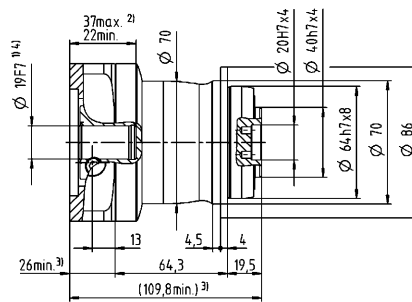
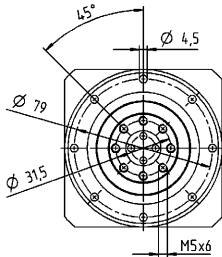

2-stage

up to 11⁴⁾ (B)⁵⁾
clamping hub diameter

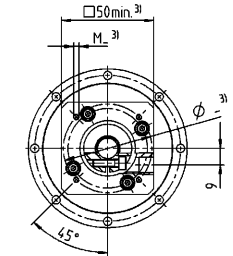
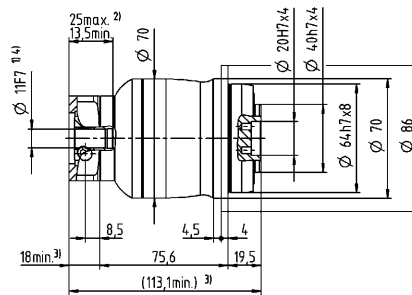
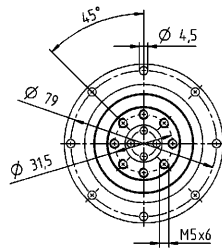

up to 14⁴⁾ (C)
clamping hub diameter

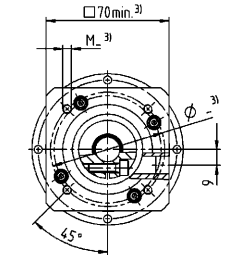
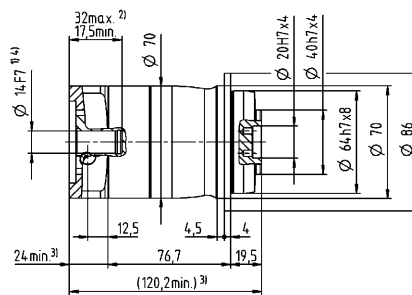
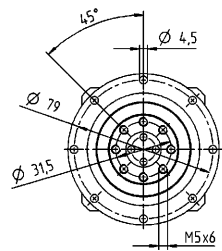

Motor shaft diameter [mm]

Non-tolerated dimensions are nominal dimensions

¹⁾ Check motor shaft fit

²⁾ Min. / Max. permissible motor shaft length

Longer motor shafts are possible, please contact alpha

³⁾ The dimensions depend on the motor

⁴⁾ Smaller motor shaft diameter is compensated

by a bushing with a minimum thickness of 1 mm

⁵⁾ Standard clamping hub diameter

NPT 025 MA 1-/2-stage

			1-stage		2-stage									
Ratio	i		3	4	9	12	15	16	20	28	30	40		
Max. torque ^{a) b)}	T_{2a}	Nm	185	185	185	185	185	185	185	185	168	185		
		in.lb	1637	1637	1637	1637	1637	1637	1637	1637	1637	1487	1637	
Max. acceleration torque (max. 1000 cycles per hour)	T_{2B}	Nm	125	115	125	125	120	115	115	115	105	115		
		in.lb	1106	1018	1106	1106	1062	1018	1018	1018	929	1018		
Emergency stop torque ^{a) b)} (permitted 1000 times during the service life of the gearbox)	T_{2Not}	Nm	190	190	190	190	190	190	190	190	190	190		
		in.lb	1682	1682	1682	1682	1682	1682	1682	1682	1682	1682		
Permitted average input speed ^{d)} (at T_{2N} and 20 °C ambient temperature)	n_{1N}	rpm	3100	3300	3300	3500	3700	3500	3700	4000	4300	4300		
Max. input speed	n_{1Max}	rpm	7000	7000	8000	8000	8000	8000	8000	8000	8000	8000		
Mean no load running torque ^{b)} (at $n_1=3000$ rpm and 20 °C gearbox temperature)	T_{012}	Nm	0.43	0.35	0.16	0.13	0.12	0.11	0.1	0.09	0.08	0.08		
		in.lb	3.8	3.1	1.4	1.2	1.1	0.97	0.89	0.8	0.71	0.71		
Max. backlash	j_t	arcmin	≤ 8		≤ 10									
Torsional rigidity ^{b)}	C_{t21}	Nm/arcmin	12	12	12	12	12	12	12	12	12	12		
		in.lb/arcmin	106	106	106	106	106	106	106	106	106	106		
Max. axial force ^{c)}	F_{2AMax}	N	1900				1900							
		lb _f	428				428							
Max. tilting moment	M_{2KMax}	Nm	79				79							
		in.lb	699				699							
Efficiency at full load	η	%	97				95							
Service life	L_n	h	> 20000				> 20000							
Weight (incl. standard adapter plate)	m	kg	4.4				4.7							
		lb _m	9.7				10							
Operating noise (at reference ratio and reference speed – ratio-specific values available in cymex®)	L_{PA}	dB(A)	≤ 61				≤ 59							
Max. permitted housing temperature		°C	+90				+90							
		°F	+194				+194							
Ambient temperature		°C	-15 to +40				-15 to +40							
		°F	+5 to +104				+5 to +104							
Lubrication			Lubricated for life											
Direction of rotation			In- and output same direction											
Protection class			IP 64											
Mass moment of inertia (relates to the drive) Clamping hub diameter [mm]	A	9	J_1	kgcm ²	-	-	0.28	0.23	0.22	0.22	0.21	0.20	0.19	0.19
				10 ⁻³ in.lb.s ²	-	-	0.25	0.2	0.19	0.19	0.19	0.18	0.17	0.17
	B	11	J_1	kgcm ²	-	-	0.3	0.25	0.23	0.24	0.23	0.21	0.21	0.21
				10 ⁻³ in.lb.s ²	-	-	0.27	0.22	0.2	0.21	0.2	0.19	0.19	0.19
	C	14	J_1	kgcm ²	0.75	0.57	0.37	0.32	0.31	0.31	0.3	0.29	0.29	0.28
				10 ⁻³ in.lb.s ²	0.66	0.5	0.33	0.28	0.27	0.27	0.27	0.26	0.26	0.25
	D	16	J_1	kgcm ²	0.9	0.72	0.5	0.45	0.44	0.44	0.43	0.42	0.41	0.41
				10 ⁻³ in.lb.s ²	0.8	0.64	0.44	0.4	0.39	0.39	0.38	0.37	0.36	0.36
	E	19	J_1	kgcm ²	0.99	0.8	0.58	0.53	0.52	0.52	0.51	0.5	0.5	0.49
				10 ⁻³ in.lb.s ²	0.88	0.71	0.51	0.47	0.46	0.46	0.45	0.44	0.44	0.43
	G	24	J_1	kgcm ²	2	1.8	-	-	-	-	-	-	-	-
				10 ⁻³ in.lb.s ²	1.8	1.6	-	-	-	-	-	-	-	-
	H	28	J_1	kgcm ²	1.7	1.5	-	-	-	-	-	-	-	-
				10 ⁻³ in.lb.s ²	1.5	1.3	-	-	-	-	-	-	-	-

Please use our sizing software cymex® for a detailed sizing – www.wittenstein-cymex.com

^{a)} Valid for torque transmission only

^{b)} Valid for standard clamping hub diameter

^{c)} Refers to center of the output shaft or flange

^{d)} Please reduce input speed at higher ambient temperatures

1-stage

up to 19⁴⁾ (E)⁵⁾
clamping hub
diameter

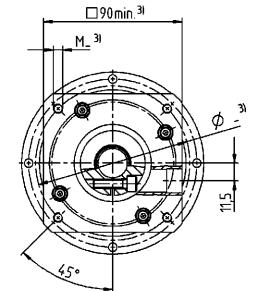
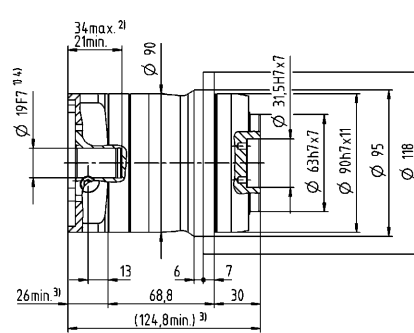
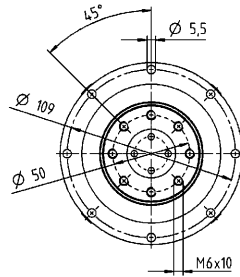

up to 28⁴⁾ (H)
clamping hub
diameter

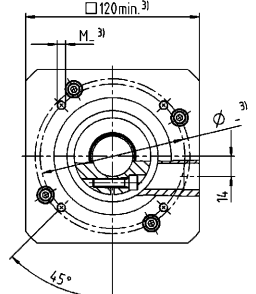
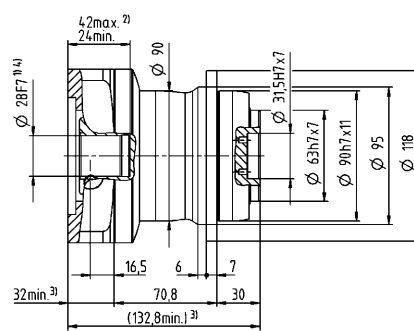
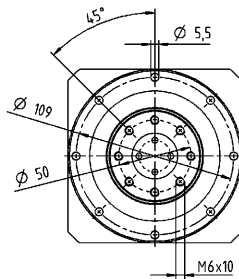

2-stage

up to 14⁴⁾ (C)⁵⁾
clamping hub
diameter

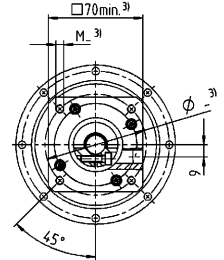
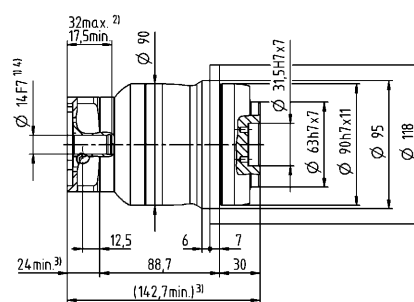
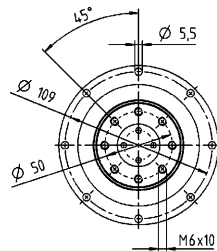

up to 19⁴⁾ (E)
clamping hub
diameter

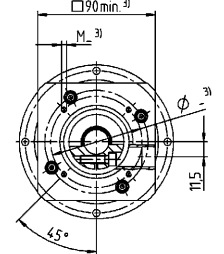
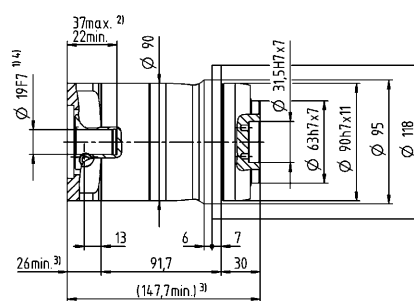
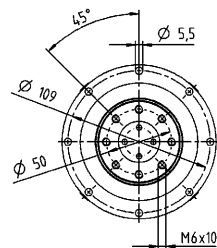

Motor shaft diameter [mm]

Non-tolerated dimensions are nominal dimensions

¹⁾ Check motor shaft fit

²⁾ Min. / Max. permissible motor shaft length

Longer motor shafts are possible, please contact alpha

³⁾ The dimensions depend on the motor

⁴⁾ Smaller motor shaft diameter is compensated

by a bushing with a minimum thickness of 1 mm

⁵⁾ Standard clamping hub diameter

NPT 035 MA 1-/2-stage

			1-stage		2-stage									
Ratio	i		3	4	9	12	15	16	20	28	30	40		
Max. torque ^{a) b)}	T_{2a}	Nm	380	380	380	380	380	380	380	380	370	380		
		in.lb	3363	3363	3363	3363	3363	3363	3363	3363	3363	3275	3363	
Max. acceleration torque (max. 1000 cycles per hour)	T_{2B}	Nm	305	305	305	305	300	305	305	305	270	305		
		in.lb	2699	2699	2699	2699	2655	2699	2699	2699	2390	2699		
Emergency stop torque ^{a) b)} (permitted 1000 times during the service life of the gearbox)	T_{2Not}	Nm	480	480	480	480	480	480	480	480	480	480		
		in.lb	4248	4248	4248	4248	4248	4248	4248	4248	4248	4248		
Permitted average input speed ^{d)} (at T_{2N} and 20 °C ambient temperature)	n_{1N}	rpm	2300	2500	3100	3300	3400	3300	3400	3600	3900	3900		
Max. input speed	n_{1Max}	rpm	6000	6000	7000	7000	7000	7000	7000	7000	7000	7000		
Mean no load running torque ^{b)} (at $n_1=3000$ rpm and 20 °C gearbox temperature)	T_{012}	Nm	1.7	1.3	0.6	0.48	0.4	0.38	0.33	0.26	0.25	0.21		
		in.lb	15	12	5.3	4.2	3.5	3.4	2.9	2.3	2.2	1.9		
Max. backlash	j_t	arcmin	≤ 8		≤ 10									
Torsional rigidity ^{b)}	C_{t21}	Nm/arcmin	30	30	30	30	30	30	30	30	30	30		
		in.lb/arcmin	266	266	266	266	266	266	266	266	266	266		
Max. axial force ^{c)}	F_{2AMax}	N	3500				3500							
		lb _f	788				788							
Max. tilting moment	M_{2KMax}	Nm	134				134							
		in.lb	1186				1186							
Efficiency at full load	η	%	97				95							
Service life	L_n	h	> 20000				> 20000							
Weight (incl. standard adapter plate)	m	kg	9.4				9.8							
		lb _m	21				22							
Operating noise (at reference ratio and reference speed – ratio-specific values available in cymex®)	L_{PA}	dB(A)	≤ 65				≤ 61							
Max. permitted housing temperature		°C	+90				+90							
		°F	+194				+194							
Ambient temperature		°C	-15 to +40				-15 to +40							
		°F	+5 to +104				+5 to +104							
Lubrication			Lubricated for life											
Direction of rotation			In- and output same direction											
Protection class			IP 64											
Mass moment of inertia (relates to the drive) Clamping hub diameter [mm]	C	14	J_1	kgcm ²	-	-	0.68	0.63	0.62	0.45	0.44	0.38	0.52	0.37
				10 ⁻³ in.lb.s ²	-	-	0.6	0.56	0.55	0.4	0.39	0.34	0.46	0.33
	D	16	J_1	kgcm ²	-	-	0.82	0.78	0.77	0.6	0.58	0.51	0.67	0.52
				10 ⁻³ in.lb.s ²	-	-	0.73	0.69	0.68	0.53	0.51	0.45	0.59	0.46
	E	19	J_1	kgcm ²	3.2	2	0.91	0.87	0.86	0.69	0.67	0.61	0.76	0.6
				10 ⁻³ in.lb.s ²	2.8	1.8	0.81	0.77	0.76	0.61	0.59	0.54	0.67	0.53
	G	24	J_1	kgcm ²	4	2.8	1.9	1.9	1.9	1.7	1.7	1.6	1.8	1.6
				10 ⁻³ in.lb.s ²	3.5	2.5	1.7	1.7	1.7	1.5	1.5	1.4	1.6	1.4
	H	28	J_1	kgcm ²	3.7	2.5	1.7	1.6	1.6	1.4	1.4	1.4	1.5	1.3
				10 ⁻³ in.lb.s ²	3.3	2.2	1.5	1.4	1.4	1.2	1.2	1.2	1.3	1.2
	I	32	J_1	kgcm ²	7.7	6.6	-	-	-	-	-	-	-	-
				10 ⁻³ in.lb.s ²	6.8	5.8	-	-	-	-	-	-	-	-
	K	38	J_1	kgcm ²	8.9	7.8	-	-	-	-	-	-	-	-
				10 ⁻³ in.lb.s ²	7.9	6.9	-	-	-	-	-	-	-	-

Please use our sizing software cymex® for a detailed sizing – www.wittenstein-cymex.com

^{a)} Valid for torque transmission only

^{b)} Valid for standard clamping hub diameter

^{c)} Refers to center of the output shaft or flange

^{d)} Please reduce input speed at higher ambient temperatures

1-stage

up to 24/28⁴⁾
(G⁵⁾/H)
clamping hub
diameter

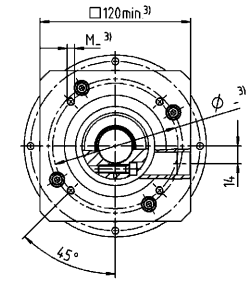
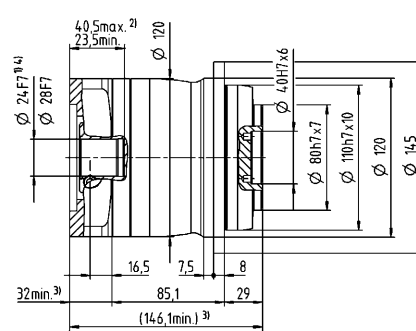
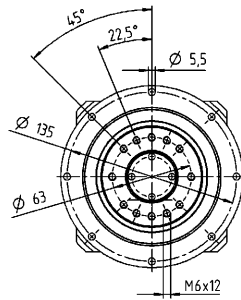

up to 38⁴⁾ (K)
clamping hub
diameter

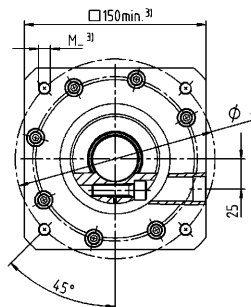
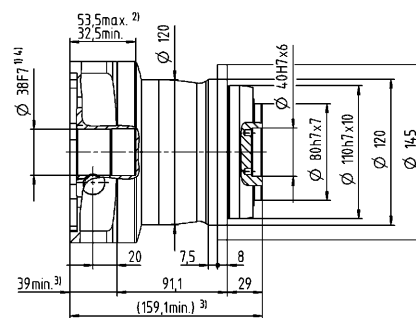
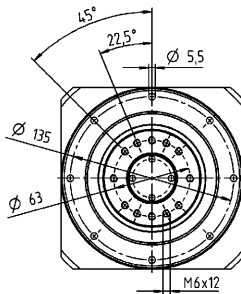

2-stage

up to 19⁴⁾ (E)⁵⁾
clamping hub
diameter

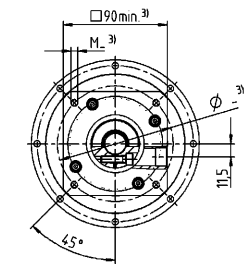
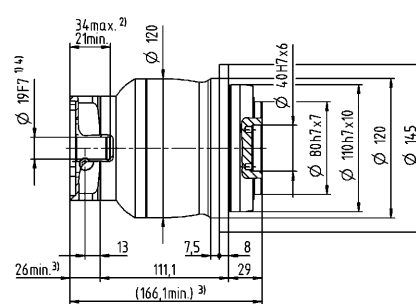
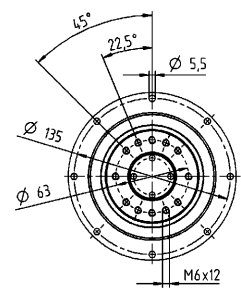

up to 28⁴⁾ (H)
clamping hub
diameter

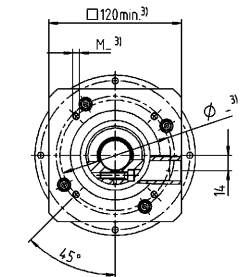
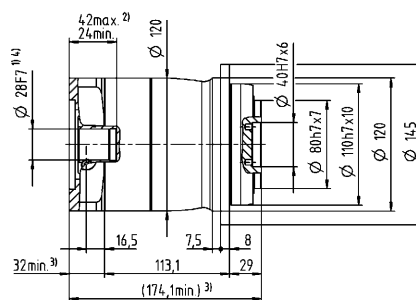
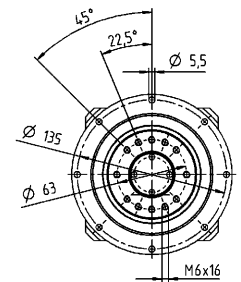

Motor shaft diameter [mm]

Non-tolerated dimensions are nominal dimensions

¹⁾ Check motor shaft fit

²⁾ Min. / Max. permissible motor shaft length

Longer motor shafts are possible, please contact alpha

³⁾ The dimensions depend on the motor

⁴⁾ Smaller motor shaft diameter is compensated

by a bushing with a minimum thickness of 1 mm

⁵⁾ Standard clamping hub diameter

NPR 015 MF 1-stage

			1-stage							
Ratio	i		3	4	5	7	8	10		
Max. torque ^{a) b) e)}	T_{2a}	Nm	51	56	64	64	56	56		
		in.lb	451	496	566	566	496	496		
Max. acceleration torque ^{e)} (max. 1000 cycles per hour)	T_{2B}	Nm	32	35	40	40	35	35		
		in.lb	283	310	354	354	310	310		
Emergency stop torque ^{a) b) e)} (permitted 1000 times during the service life of the gearbox)	T_{2Not}	Nm	80	80	80	80	80	80		
		in.lb	708	708	708	708	708	708		
Permitted average input speed ^{d)} (at T_{2N} and 20 °C ambient temperature)	n_{1N}	rpm	2600	2800	2900	3400	3400	3600		
Max. input speed	n_{1Max}	rpm	8000	8000	8000	8000	8000	8000		
Mean no load running torque ^{b)} (at $n_1=3000$ rpm and 20 °C gearbox temperature)	T_{012}	Nm	0.98	0.78	0.66	0.52	0.48	0.42		
		in.lb	8.7	6.9	5.8	4.6	4.2	3.7		
Max. backlash	j_l	arcmin	≤ 8							
Torsional rigidity ^{b)}	C_{121}	Nm/arcmin	3.3	3.3	3.3	3.3	2.8	2.8		
		in.lb/arcmin	29	29	29	29	25	25		
Max. axial force ^{c)}	F_{2AMax}	N	2400							
		lb _f	540							
Max. lateral force ^{c)}	F_{2QMMax}	N	2800							
		lb _f	630							
Max. tilting moment	M_{2KMMax}	Nm	152							
		in.lb	1345							
Efficiency at full load	η	%	97							
Service life	L_n	h	> 20000							
Weight (incl. standard adapter plate)	m	kg	1.9							
		lb _m	4.2							
Operating noise (at reference ratio and reference speed – ratio-specific values available in cymex [®])	L_{PA}	dB(A)	≤ 59							
Max. permitted housing temperature		°C	+90							
		°F	+194							
Ambient temperature		°C	-15 to +40							
		°F	+5 to +104							
Lubrication			Lubricated for life							
Direction of rotation			In- and output same direction							
Protection class			IP 65							
Elastomer coupling (recommended product type – validate sizing with cymex [®])			ELC-0060BA016.000-X							
Bore diameter of coupling on the application side		mm	X = 012.000 - 032.000							
Mass moment of inertia (relates to the drive) Clamping hub diameter [mm]	A	9	J_1	kgcm ²	0.25	0.19	0.17	0.14	0.14	0.13
				10 ⁻³ in.lb.s ²	0.22	0.17	0.15	0.12	0.12	0.12
	B	11	J_1	kgcm ²	0.26	0.21	0.18	0.16	0.16	0.15
				10 ⁻³ in.lb.s ²	0.23	0.19	0.16	0.14	0.14	0.13
	C	14	J_1	kgcm ²	0.34	0.28	0.26	0.24	0.23	0.23
				10 ⁻³ in.lb.s ²	0.3	0.25	0.23	0.21	0.2	0.2
	D	16	J_1	kgcm ²	0.47	0.41	0.39	0.36	0.36	0.35
				10 ⁻³ in.lb.s ²	0.42	0.36	0.35	0.32	0.32	0.31
	E	19	J_1	kgcm ²	0.55	0.49	0.47	0.45	0.44	0.44
				10 ⁻³ in.lb.s ²	0.49	0.43	0.42	0.4	0.39	0.39

Please use our sizing software cymex[®] for a detailed sizing – www.wittenstein-cymex.com

^{a)} Valid for torque transmission only

^{b)} Valid for standard clamping hub diameter

^{c)} Refers to center of the output shaft or flange

^{d)} Please reduce input speed at higher ambient temperatures

^{e)} Valid for: Smooth shaft

1-stage

Motor shaft diameter [mm]

up to 14⁴⁾ (C)⁵⁾
clamping hub diameter

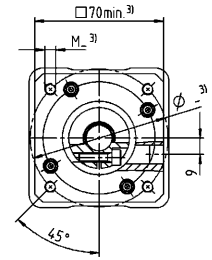
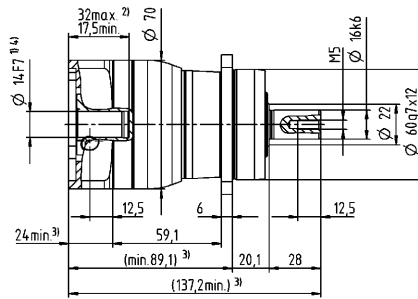
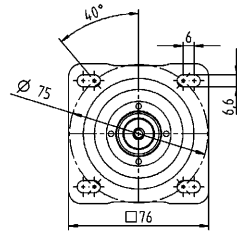

up to 19⁴⁾ (E)
clamping hub diameter

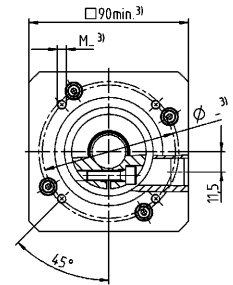
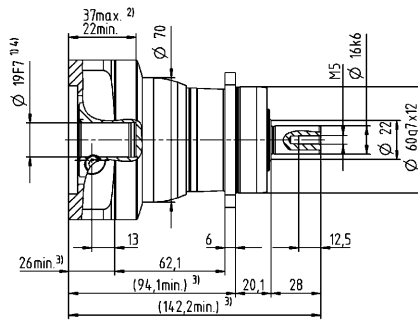
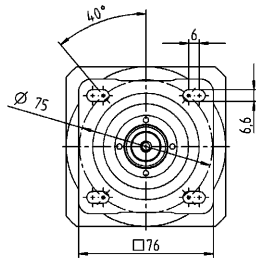

Other output variants

Shaft with key

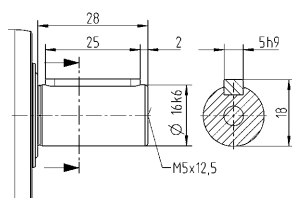

Splined shaft (DIN 5480)

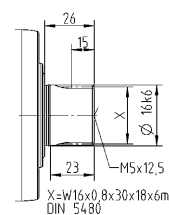

Non-tolerated dimensions are nominal dimensions

¹⁾ Check motor shaft fit

²⁾ Min. / Max. permissible motor shaft length

Longer motor shafts are possible, please contact alpha

³⁾ The dimensions depend on the motor

⁴⁾ Smaller motor shaft diameter is compensated

by a bushing with a minimum thickness of 1 mm

⁵⁾ Standard clamping hub diameter

NPR 015 MF 2-stage

			2-stage														
Ratio	i		12	15	16	20	25	28	30	32	35	40	50	64	70	100	
Max. torque ^{a) b) e)}	T_{2a}	Nm	51	51	56	56	64	56	51	56	64	56	64	56	64	56	
		in.lb	451	451	496	496	566	496	451	496	566	496	566	496	566	496	566
Max. acceleration torque ^{e)} (max. 1000 cycles per hour)	T_{2B}	Nm	32	32	35	35	40	35	32	35	40	35	40	35	40	35	
		in.lb	283	283	310	310	354	310	283	310	354	310	354	310	354	310	354
Emergency stop torque ^{a) b) e)} (permitted 1000 times during the service life of the gearbox)	T_{2Not}	Nm	80	80	80	80	80	80	80	80	80	80	80	80	80	80	
		in.lb	708	708	708	708	708	708	708	708	708	708	708	708	708	708	708
Permitted average input speed ^{d)} (at T_{2a} and 20 °C ambient temperature)	n_{1N}	rpm	3800	4000	3800	4000	4000	4300	4600	4400	4300	4600	4600	4400	4600	4600	
Max. input speed	n_{1Max}	rpm	10000	10000	10000	10000	10000	10000	10000	10000	10000	10000	10000	10000	10000	10000	
Mean no load running torque ^{b)} (at $n_1=3000$ rpm and 20 °C gearbox temperature)	T_{012}	Nm	0.34	0.29	0.29	0.25	0.23	0.21	0.21	0.2	0.2	0.19	0.17	0.17	0.16	0.15	
		in.lb	3	2.6	2.6	2.2	2	1.9	1.9	1.8	1.8	1.7	1.5	1.5	1.4	1.3	
Max. backlash	j_l	arcmin	≤ 10														
Torsional rigidity ^{b)}	C_{121}	Nm/arcmin	3.3	3.3	3.3	3.3	3.3	3.3	3.3	3.3	3.3	3.3	3.3	2.8	3.3	2.8	
		in.lb/arcmin	29	29	29	29	29	29	29	29	29	29	29	25	29	25	
Max. axial force ^{c)}	F_{2AMax}	N	2400														
		lb _f	540														
Max. lateral force ^{c)}	F_{2QMMax}	N	2800														
		lb _f	630														
Max. tilting moment	M_{2KMMax}	Nm	152														
		in.lb	1345														
Efficiency at full load	η	%	95														
Service life	L_n	h	> 20000														
Weight (incl. standard adapter plate)	m	kg	2														
		lb _m	4.4														
Operating noise (at reference ratio and reference speed – ratio-specific values available in cymex [®])	L_{PA}	dB(A)	≤ 58														
Max. permitted housing temperature		°C	+90														
		°F	+194														
Ambient temperature		°C	-15 to +40														
		°F	+5 to +104														
Lubrication			Lubricated for life														
Direction of rotation			In- and output same direction														
Protection class			IP 65														
Elastomer coupling (recommended product type – validate sizing with cymex [®])			ELC-0060BA016.000-X														
Bore diameter of coupling on the application side		mm	X = 012.000 - 032.000														
Mass moment of inertia (relates to the drive) Clamping hub diameter [mm]	Z	8	J_1	kgcm ²	0.04	0.04	0.03	0.03	0.03	0.03	0.03	0.03	0.03	0.02	0.02	0.02	0.02
				10 ⁻³ in.lb.s ²	0.04	0.04	0.03	0.03	0.03	0.03	0.03	0.03	0.03	0.03	0.02	0.02	0.02
	A	9	J_1	kgcm ²	0.04	0.04	0.03	0.03	0.03	0.03	0.03	0.03	0.03	0.02	0.02	0.02	0.02
				10 ⁻³ in.lb.s ²	0.04	0.04	0.03	0.03	0.03	0.03	0.03	0.03	0.03	0.02	0.02	0.02	0.02
	B	11	J_1	kgcm ²	0.06	0.06	0.05	0.05	0.05	0.05	0.05	0.04	0.05	0.04	0.04	0.04	
				10 ⁻³ in.lb.s ²	0.05	0.05	0.04	0.04	0.04	0.04	0.04	0.04	0.04	0.04	0.04	0.04	0.04
	C	14	J_1	kgcm ²	0.14	0.14	0.14	0.13	0.13	0.13	0.14	0.13	0.13	0.13	0.13	0.13	
				10 ⁻³ in.lb.s ²	0.12	0.12	0.12	0.12	0.12	0.12	0.12	0.12	0.12	0.12	0.12	0.12	0.12

Please use our sizing software cymex[®] for a detailed sizing – www.wittenstein-cymex.com

^{a)} Valid for torque transmission only

^{b)} Valid for standard clamping hub diameter

^{c)} Refers to center of the output shaft or flange

^{d)} Please reduce input speed at higher ambient temperatures

^{e)} Valid for: Smooth shaft

2-stage

Motor shaft diameter [mm]

up to 11⁴⁾ (B)⁵⁾
clamping hub diameter

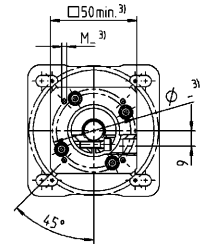
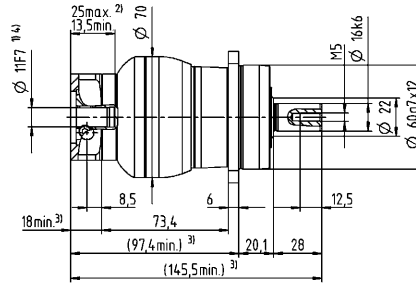
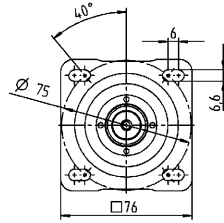

up to 14⁴⁾ (C)
clamping hub diameter

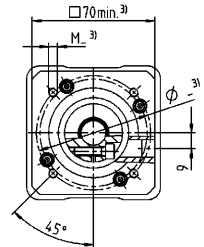
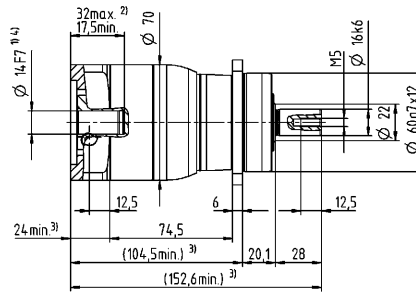
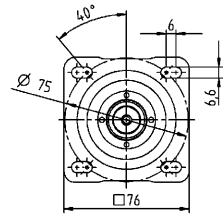

Other output variants

Shaft with key

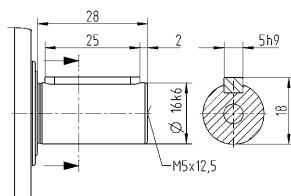

Splined shaft (DIN 5480)

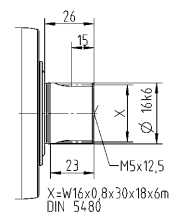

Non-tolerated dimensions are nominal dimensions

¹⁾ Check motor shaft fit

²⁾ Min. / Max. permissible motor shaft length

Longer motor shafts are possible, please contact alpha

³⁾ The dimensions depend on the motor

⁴⁾ Smaller motor shaft diameter is compensated

by a bushing with a minimum thickness of 1 mm

⁵⁾ Standard clamping hub diameter

NPR 025 MF 1-stage

			1-stage							
Ratio	i		3	4	5	7	8	10		
Max. torque ^{a) b) e)}	T_{2a}	Nm	128	152	160	160	144	144		
		in.lb	1133	1345	1416	1416	1275	1275		
Max. acceleration torque ^{e)} (max. 1000 cycles per hour)	T_{2B}	Nm	80	95	100	100	90	90		
		in.lb	708	841	885	885	797	797		
Emergency stop torque ^{a) b) e)} (permitted 1000 times during the service life of the gearbox)	T_{2Not}	Nm	190	190	190	190	190	190		
		in.lb	1682	1682	1682	1682	1682	1682		
Permitted average input speed ^{d)} (at T_{2N} and 20 °C ambient temperature)	n_{1N}	rpm	2400	2600	2700	3000	3100	3300		
Max. input speed	n_{1Max}	rpm	7000	7000	7000	7000	7000	7000		
Mean no load running torque ^{b)} (at $n_1=3000$ rpm and 20 °C gearbox temperature)	T_{012}	Nm	1.9	1.6	1.4	1.1	1.1	0.96		
		in.lb	17	14	12	9.7	9.7	8.5		
Max. backlash	j_l	arcmin	≤ 8							
Torsional rigidity ^{b)}	C_{121}	Nm/arcmin	9.5	9.5	9.5	9.5	8.5	8.5		
		in.lb/arcmin	84	84	84	84	75	75		
Max. axial force ^{c)}	F_{2AMax}	N	3350							
		lb _f	754							
Max. lateral force ^{c)}	F_{2QMMax}	N	4200							
		lb _f	945							
Max. tilting moment	M_{2KMMax}	Nm	236							
		in.lb	2089							
Efficiency at full load	η	%	97							
Service life	L_n	h	> 20000							
Weight (incl. standard adapter plate)	m	kg	3.7							
		lb _m	8.2							
Operating noise (at reference ratio and reference speed – ratio-specific values available in cymex [®])	L_{PA}	dB(A)	≤ 61							
Max. permitted housing temperature		°C	+90							
		°F	+194							
Ambient temperature		°C	-15 to +40							
		°F	+5 to +104							
Lubrication			Lubricated for life							
Direction of rotation			In- and output same direction							
Protection class			IP 65							
Elastomer coupling (recommended product type – validate sizing with cymex [®])			ELC-0060BA022.000-X							
Bore diameter of coupling on the application side		mm	X = 012.000 - 032.000							
Mass moment of inertia (relates to the drive) Clamping hub diameter [mm]	C	14	J_1	kgcm ²	0.58	0.47	0.38	0.3	0.28	0.26
				10 ⁻³ in.lb.s ²	0.51	0.42	0.34	0.27	0.25	0.23
	D	16	J_1	kgcm ²	0.73	0.62	0.53	0.43	0.42	0.4
				10 ⁻³ in.lb.s ²	0.65	0.55	0.47	0.38	0.37	0.35
	E	19	J_1	kgcm ²	0.81	0.71	0.61	0.53	0.51	0.49
				10 ⁻³ in.lb.s ²	0.72	0.63	0.54	0.47	0.45	0.43
	G	24	J_1	kgcm ²	1.8	1.7	1.6	1.6	1.5	1.5
				10 ⁻³ in.lb.s ²	1.6	1.5	1.4	1.4	1.3	1.3
	H	28	J_1	kgcm ²	1.6	1.4	1.4	1.3	1.3	1.2
				10 ⁻³ in.lb.s ²	1.4	1.2	1.2	1.2	1.2	1.1

Please use our sizing software cymex[®] for a detailed sizing – www.wittenstein-cymex.com

^{a)} Valid for torque transmission only

^{b)} Valid for standard clamping hub diameter

^{c)} Refers to center of the output shaft or flange

^{d)} Please reduce input speed at higher ambient temperatures

^{e)} Valid for: Smooth shaft

1-stage

up to 19⁴⁾ (E)⁵⁾
clamping hub
diameter

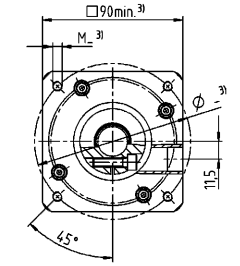
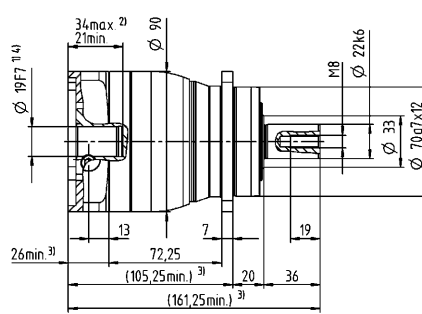
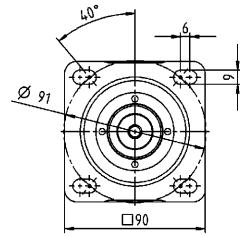

Motor shaft diameter [mm]

up to 28⁴⁾ (H)
clamping hub
diameter

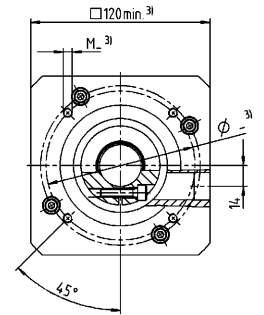
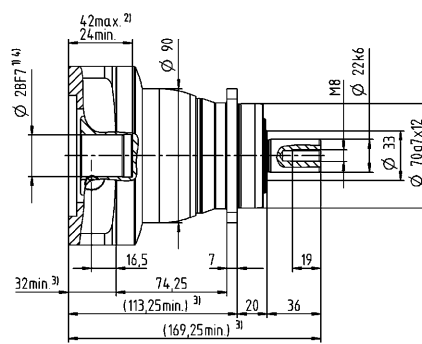
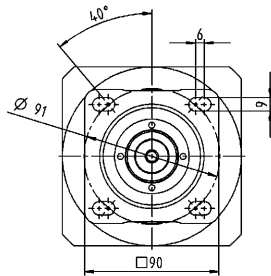

Planetary Gearboxes
Value Line

Other output variants

Shaft with key

Splined shaft (DIN 5480)

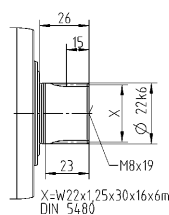
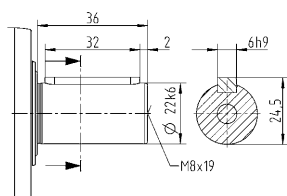

Non-tolerated dimensions are nominal dimensions

¹⁾ Check motor shaft fit

²⁾ Min. / Max. permissible motor shaft length

Longer motor shafts are possible, please contact alpha

³⁾ The dimensions depend on the motor

⁴⁾ Smaller motor shaft diameter is compensated

by a bushing with a minimum thickness of 1 mm

⁵⁾ Standard clamping hub diameter

NPR 025 MF 2-stage

			2-stage															
Ratio	i		9	12	15	16	20	25	28	30	32	35	40	50	64	70	100	
Max. torque ^{a) b) e)}	T_{2a}	Nm	128	128	128	152	152	160	152	128	144	160	152	160	144	160	144	
		in.lb	1133	1133	1133	1345	1345	1416	1345	1133	1275	1416	1345	1416	1275	1416	1275	
Max. acceleration torque ^{e)} (max. 1000 cycles per hour)	T_{2B}	Nm	80	80	80	95	95	100	95	80	90	100	95	100	90	100	90	
		in.lb	708	708	708	841	841	885	841	708	797	885	841	885	797	885	797	
Emergency stop torque ^{a) b) e)} (permitted 1000 times during the service life of the gearbox)	T_{2Not}	Nm	190	190	190	190	190	190	190	190	190	190	190	190	190	190	190	
		in.lb	1682	1682	1682	1682	1682	1682	1682	1682	1682	1682	1682	1682	1682	1682	1682	
Permitted average input speed ^{d)} (at T_{2N} and 20 °C ambient temperature)	n_{1N}	rpm	2800	3500	3700	3500	3700	3700	4000	4300	4100	4000	4300	4300	4100	4300	4300	
Max. input speed	n_{1Max}	rpm	8000	8000	8000	8000	8000	8000	8000	8000	8000	8000	8000	8000	8000	8000	8000	
Mean no load running torque ^{b)} (at $n_1=3000$ rpm and 20 °C gearbox temperature)	T_{012}	Nm	0.67	0.55	0.47	0.46	0.4	0.36	0.34	0.33	0.32	0.31	0.29	0.27	0.25	0.25	0.23	
		in.lb	5.9	4.9	4.2	4.1	3.5	3.2	3	2.9	2.8	2.7	2.6	2.4	2.2	2.2	2	
Max. backlash	j_l	arcmin	≤ 10															
Torsional rigidity ^{b)}	C_{121}	Nm/arcmin	10	10	10	10	10	9.5	10	10	10	9.5	10	9.5	8.5	9.5	8.5	
		in.lb/arcmin	89	89	89	89	89	84	89	89	89	84	89	84	75	84	75	
Max. axial force ^{c)}	F_{2AMax}	N	3350															
		lb _f	754															
Max. lateral force ^{c)}	F_{2QMMax}	N	4200															
		lb _f	945															
Max. tilting moment	M_{2KMMax}	Nm	236															
		in.lb	2089															
Efficiency at full load	η	%	95															
Service life	L_n	h	> 20000															
Weight (incl. standard adapter plate)	m	kg	4															
		lb _m	8.8															
Operating noise (at reference ratio and reference speed – ratio-specific values available in cymex [®])	L_{PA}	dB(A)	≤ 59															
Max. permitted housing temperature		°C	+90															
		°F	+194															
Ambient temperature		°C	-15 to +40															
		°F	+5 to +104															
Lubrication			Lubricated for life															
Direction of rotation			In- and output same direction															
Protection class			IP 65															
Elastomer coupling (recommended product type – validate sizing with cymex [®])			ELC-0060BA022.000-X															
Bore diameter of coupling on the application side		mm	X = 012.000 - 032.000															
Mass moment of inertia (relates to the drive) Clamping hub diameter [mm]	A	9	J_1	kgcm ²	0.26	0.22	0.21	0.21	0.2	0.2	0.19	0.19	0.19	0.19	0.19	0.19	0.19	0.19
				10 ⁻³ in.lb.s ²	0.23	0.19	0.19	0.19	0.18	0.18	0.17	0.17	0.17	0.17	0.17	0.17	0.17	0.17
	B	11	J_1	kgcm ²	0.28	0.24	0.23	0.23	0.22	0.22	0.21	0.21	0.21	0.21	0.21	0.21	0.21	0.21
				10 ⁻³ in.lb.s ²	0.25	0.21	0.2	0.2	0.19	0.19	0.19	0.19	0.19	0.19	0.19	0.19	0.19	0.19
	C	14	J_1	kgcm ²	0.35	0.31	0.3	0.3	0.3	0.29	0.29	0.28	0.28	0.28	0.28	0.28	0.28	0.28
				10 ⁻³ in.lb.s ²	0.31	0.27	0.27	0.27	0.27	0.26	0.26	0.25	0.25	0.25	0.25	0.25	0.25	0.25
	D	16	J_1	kgcm ²	0.48	0.44	0.43	0.43	0.42	0.42	0.41	0.41	0.41	0.41	0.41	0.41	0.41	0.41
				10 ⁻³ in.lb.s ²	0.42	0.39	0.38	0.38	0.37	0.37	0.36	0.36	0.36	0.36	0.36	0.36	0.36	0.36
	E	19	J_1	kgcm ²	0.56	0.52	0.51	0.52	0.51	0.5	0.5	0.5	0.5	0.5	0.49	0.49	0.49	0.49
				10 ⁻³ in.lb.s ²	0.5	0.46	0.45	0.46	0.45	0.44	0.44	0.44	0.44	0.44	0.43	0.43	0.43	0.43

Please use our sizing software cymex[®] for a detailed sizing – www.wittenstein-cymex.com

^{a)} Valid for torque transmission only

^{b)} Valid for standard clamping hub diameter

^{c)} Refers to center of the output shaft or flange

^{d)} Please reduce input speed at higher ambient temperatures

^{e)} Valid for: Smooth shaft

2-stage

Motor shaft diameter [mm]

up to 14⁴⁾ (C)⁵⁾
clamping hub diameter

up to 19⁴⁾ (E)
clamping hub diameter

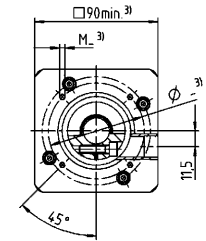
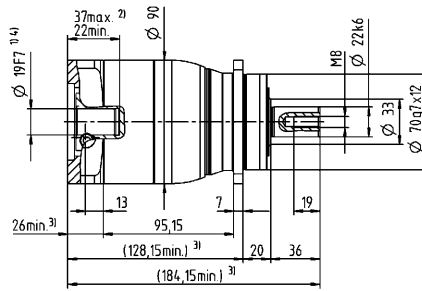
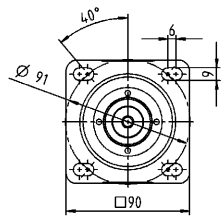
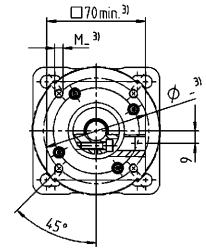
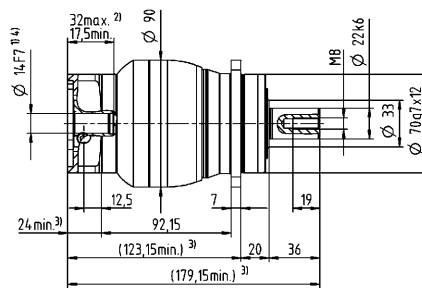
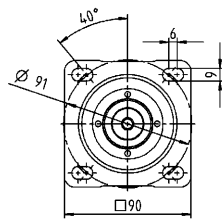

Planetary Gearboxes
Value Line

Other output variants

Shaft with key

Splined shaft (DIN 5480)

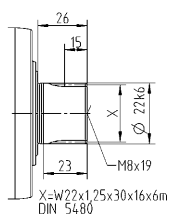
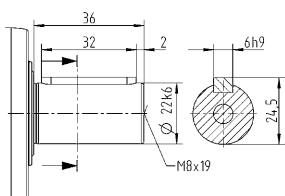

X=W22x1,25x30x16x6mm
DIN 5480

Non-tolerated dimensions are nominal dimensions

¹⁾ Check motor shaft fit

²⁾ Min. / Max. permissible motor shaft length

Longer motor shafts are possible, please contact alpha

³⁾ The dimensions depend on the motor

⁴⁾ Smaller motor shaft diameter is compensated

by a bushing with a minimum thickness of 1 mm

⁵⁾ Standard clamping hub diameter

NPR 035 MF 1-stage

			1-stage							
Ratio	i		3	4	5	7	8	10		
Max. torque ^{a) b) e)}	T_{2a}	Nm	320	408	400	400	352	352		
		in.lb	2832	3611	3540	3540	3115	3115		
Max. acceleration torque ^{e)} (max. 1000 cycles per hour)	T_{2B}	Nm	200	255	250	250	220	220		
		in.lb	1770	2257	2213	2213	1947	1947		
Emergency stop torque ^{a) b) e)} (permitted 1000 times during the service life of the gearbox)	T_{2Not}	Nm	500	500	500	500	500	500		
		in.lb	4425	4425	4425	4425	4425	4425		
Permitted average input speed ^{d)} (at T_{2a} and 20 °C ambient temperature)	n_{1N}	rpm	1800	2000	2000	2300	2400	2500		
Max. input speed	n_{1Max}	rpm	6000	6000	6000	6000	6000	6000		
Mean no load running torque ^{b)} (at $n_1=3000$ rpm and 20 °C gearbox temperature)	T_{012}	Nm	3.5	2.8	2.4	1.9	1.8	1.6		
		in.lb	31	25	21	17	16	14		
Max. backlash	j_l	arcmin	≤ 8							
Torsional rigidity ^{b)}	C_{t21}	Nm/arcmin	25	25	25	25	22	22		
		in.lb/arcmin	221	221	221	221	195	195		
Max. axial force ^{c)}	F_{2AMax}	N	5650							
		lb _f	1271							
Max. lateral force ^{c)}	F_{2QMMax}	N	6600							
		lb _f	1485							
Max. tilting moment	M_{2KMMax}	Nm	487							
		in.lb	4310							
Efficiency at full load	η	%	97							
Service life	L_n	h	> 20000							
Weight (incl. standard adapter plate)	m	kg	8.6							
		lb _m	19							
Operating noise (at reference ratio and reference speed – ratio-specific values available in cymex [®])	L_{PA}	dB(A)	≤ 65							
Max. permitted housing temperature		°C	+90							
		°F	+194							
Ambient temperature		°C	-15 to +40							
		°F	+5 to +104							
Lubrication			Lubricated for life							
Direction of rotation			In- and output same direction							
Protection class			IP 65							
Elastomer coupling (recommended product type – validate sizing with cymex [®])			ELC-0150BA032.000-X							
Bore diameter of coupling on the application side		mm	X = 019.000 - 036.000							
Mass moment of inertia (relates to the drive) Clamping hub diameter [mm]	E	19	J_1	kgcm ²	2.5	1.7	1.3	1	0.94	0.87
				10 ⁻³ in.lb.s ²	2.2	1.5	1.2	0.89	0.83	0.77
	G	24	J_1	kgcm ²	3.3	2.4	2.1	1.8	1.7	1.6
				10 ⁻³ in.lb.s ²	2.9	2.1	1.9	1.6	1.5	1.4
	H	28	J_1	kgcm ²	3	2.2	1.8	1.5	1.4	1.4
				10 ⁻³ in.lb.s ²	2.7	1.9	1.6	1.3	1.2	1.2
	I	32	J_1	kgcm ²	7.1	6.2	5.9	5.6	5.5	5.4
				10 ⁻³ in.lb.s ²	6.3	5.5	5.2	5	4.9	4.8
	K	38	J_1	kgcm ²	8.3	7.4	7.1	6.7	6.6	6.6
				10 ⁻³ in.lb.s ²	7.3	6.5	6.3	5.9	5.8	5.8

Please use our sizing software cymex[®] for a detailed sizing – www.wittenstein-cymex.com

^{a)} Valid for torque transmission only

^{b)} Valid for standard clamping hub diameter

^{c)} Refers to center of the output shaft or flange

^{d)} Please reduce input speed at higher ambient temperatures

^{e)} Valid for: Smooth shaft

1-stage

Motor shaft diameter [mm]

up to 24/28⁴⁾
(G⁵⁾/H)
clamping hub diameter

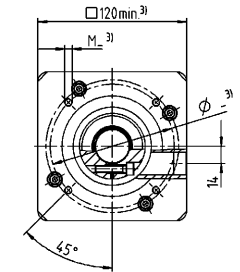
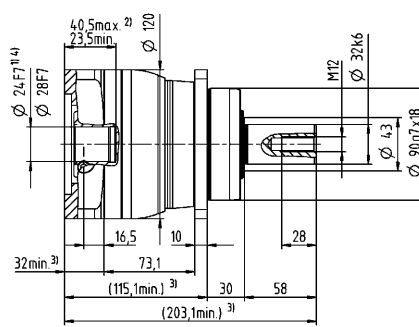
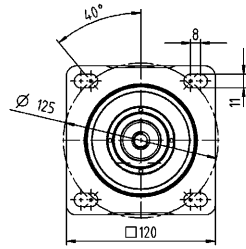

up to 38⁴⁾ (K)
clamping hub diameter

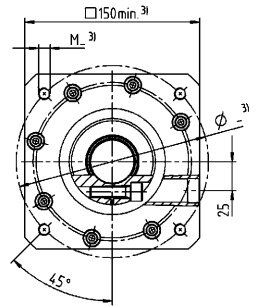
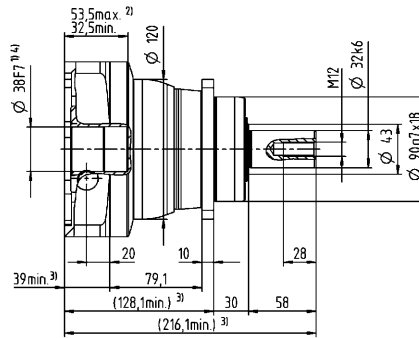
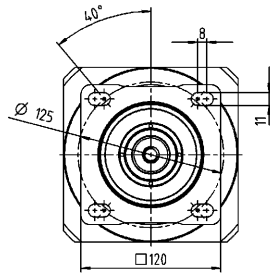

Other output variants

Shaft with key

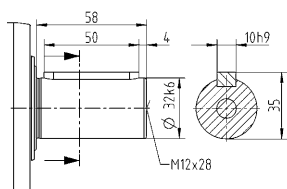

Splined shaft (DIN 5480)

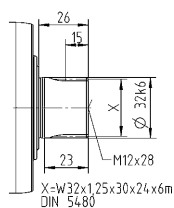

Non-tolerated dimensions are nominal dimensions

¹⁾ Check motor shaft fit

²⁾ Min. / Max. permissible motor shaft length

Longer motor shafts are possible, please contact alpha

³⁾ The dimensions depend on the motor

⁴⁾ Smaller motor shaft diameter is compensated

by a bushing with a minimum thickness of 1 mm

⁵⁾ Standard clamping hub diameter

NPR 035 MF 2-stage

			2-stage																
Ratio	i		9	12	15	16	20	25	28	30	32	35	40	50	64	70	100		
Max. torque ^{a) b) e)}	T_{2a}	Nm	320	320	320	408	408	400	408	320	408	400	408	400	352	400	352		
		in.lb	2832	2832	2832	3611	3611	3540	3611	2832	3611	3540	3611	3540	3115	3540	3115		
Max. acceleration torque ^{e)} (max. 1000 cycles per hour)	T_{2B}	Nm	200	200	200	255	255	250	255	200	255	250	255	250	220	250	220		
		in.lb	1770	1770	1770	2257	2257	2213	2257	1770	2257	2213	2257	2213	1947	2213	1947		
Emergency stop torque ^{a) b) e)} (permitted 1000 times during the service life of the gearbox)	T_{2Not}	Nm	500	500	500	500	500	500	500	500	500	500	500	500	500	500	500		
		in.lb	4425	4425	4425	4425	4425	4425	4425	4425	4425	4425	4425	4425	4425	4425	4425		
Permitted average input speed ^{d)} (at T_{2a} and 20 °C ambient temperature)	n_{1N}	rpm	2600	3300	3400	3300	3400	3400	3600	3900	3700	3600	3900	3900	3700	3900	3900		
Max. input speed	n_{1Max}	rpm	7000	7000	7000	7000	7000	7000	7000	7000	7000	7000	7000	7000	7000	7000	7000		
Mean no load running torque ^{b)} (at $n_1=3000$ rpm and 20 °C gearbox temperature)	T_{012}	Nm	1.7	1.4	1.2	1.2	1.1	1	0.93	0.88	0.88	0.87	0.81	0.77	0.75	0.72	0.68		
		in.lb	15	12	11	11	9.7	8.9	8.2	7.8	7.8	7.7	7.2	6.8	6.6	6.4	6		
Max. backlash	j_l	arcmin	≤ 10																
Torsional rigidity ^{b)}	C_{i21}	Nm/arcmin	25	25	25	25	25	25	25	25	25	25	25	25	22	25	22		
		in.lb/arcmin	221	221	221	221	221	221	221	221	221	221	221	221	195	221	195		
Max. axial force ^{c)}	F_{2AMax}	N	5650																
		lb _f	1271																
Max. lateral force ^{c)}	F_{2QMMax}	N	6600																
		lb _f	1485																
Max. tilting moment	M_{2KMMax}	Nm	487																
		in.lb	4310																
Efficiency at full load	η	%	95																
Service life	L_n	h	> 20000																
Weight (incl. standard adapter plate)	m	kg	9																
		lb _m	20																
Operating noise (at reference ratio and reference speed – ratio-specific values available in cymex [®])	L_{PA}	dB(A)	≤ 61																
Max. permitted housing temperature		°C	+90																
		°F	+194																
Ambient temperature		°C	-15 to +40																
		°F	+5 to +104																
Lubrication			Lubricated for life																
Direction of rotation			In- and output same direction																
Protection class			IP 65																
Elastomer coupling (recommended product type – validate sizing with cymex [®])			ELC-0150BA032.000-X																
Bore diameter of coupling on the application side		mm	X = 019.000 - 036.000																
Mass moment of inertia (relates to the drive) Clamping hub diameter [mm]	C	14	J_1	kgcm ²	0.6	0.59	0.6	0.43	0.42	0.36	0.37	0.52	0.38	0.32	0.36	0.31	0.26	0.27	0.24
				10 ⁻³ in.lb.s ²	0.53	0.52	0.53	0.38	0.37	0.32	0.33	0.46	0.34	0.28	0.32	0.27	0.23	0.24	0.21
	D	16	J_1	kgcm ²	0.75	0.74	0.74	0.58	0.57	0.5	0.5	0.67	0.52	0.45	0.51	0.46	0.4	0.41	0.39
				10 ⁻³ in.lb.s ²	0.66	0.65	0.65	0.51	0.5	0.44	0.44	0.59	0.46	0.4	0.45	0.41	0.35	0.36	0.35
	E	19	J_1	kgcm ²	0.84	0.83	0.83	0.66	0.65	0.59	0.6	0.75	0.61	0.55	0.6	0.54	0.49	0.5	0.48
				10 ⁻³ in.lb.s ²	0.74	0.73	0.73	0.58	0.58	0.52	0.53	0.66	0.54	0.49	0.53	0.48	0.43	0.44	0.42
	G	24	J_1	kgcm ²	1.9	1.9	1.9	1.7	1.7	1.6	1.6	1.8	1.6	1.6	1.6	1.6	1.5	1.5	1.5
				10 ⁻³ in.lb.s ²	1.7	1.6	1.7	1.5	1.5	1.4	1.5	1.6	1.5	1.4	1.4	1.4	1.4	1.3	1.4
	H	28	J_1	kgcm ²	1.6	1.6	1.6	1.4	1.4	1.3	1.3	1.5	1.4	1.3	1.3	1.3	1.2	1.2	1.2
				10 ⁻³ in.lb.s ²	1.4	1.4	1.4	1.2	1.2	1.2	1.2	1.3	1.2	1.1	1.2	1.1	1.1	1.1	1.1

Please use our sizing software cymex[®] for a detailed sizing – www.wittenstein-cymex.com

^{a)} Valid for torque transmission only

^{b)} Valid for standard clamping hub diameter

^{c)} Refers to center of the output shaft or flange

^{d)} Please reduce input speed at higher ambient temperatures

^{e)} Valid for: Smooth shaft

2-stage

Motor shaft diameter [mm]

up to 19⁴⁾ (E)⁵⁾
clamping hub diameter

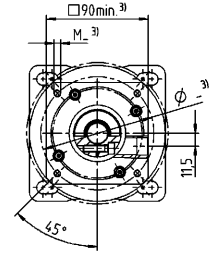
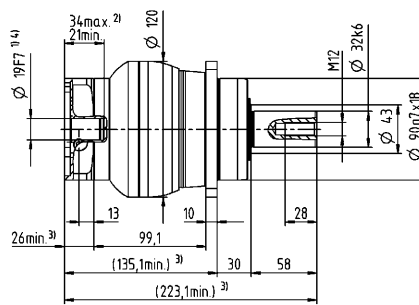
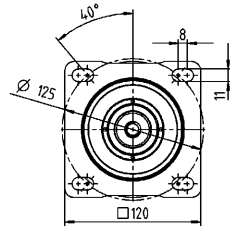

up to 28⁴⁾ (H)
clamping hub diameter

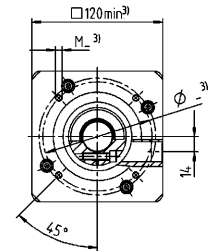
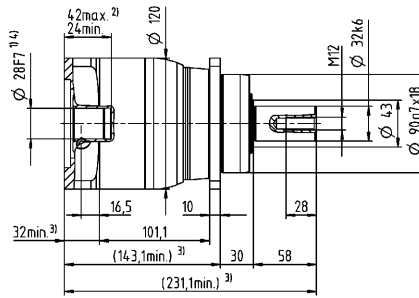
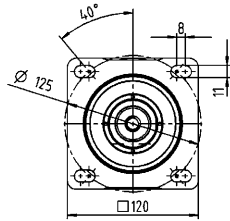

Planetary Gearboxes
Value Line

Other output variants

Shaft with key

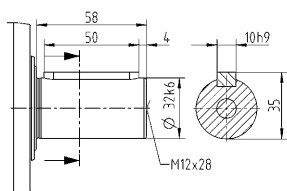

Splined shaft (DIN 5480)

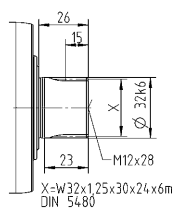

Non-tolerated dimensions are nominal dimensions

¹⁾ Check motor shaft fit

²⁾ Min. / Max. permissible motor shaft length

Longer motor shafts are possible, please contact alpha

³⁾ The dimensions depend on the motor

⁴⁾ Smaller motor shaft diameter is compensated

by a bushing with a minimum thickness of 1 mm

⁵⁾ Standard clamping hub diameter

NPR 045 MF 1-/2-stage

			1-stage			2-stage						
Ratio	i		5	8	10	25	32	50	64	100		
Max. torque ^{a) b) e)}	T_{2a}	Nm	800	640	640	700	640	700	640	640		
		in.lb	7081	5665	5665	6196	5665	6196	5665	5665		
Max. acceleration torque ^{e)} (max. 1000 cycles per hour)	T_{2B}	Nm	500	400	400	500	400	500	400	400		
		in.lb	4425	3540	3540	4425	3540	4425	3540	3540		
Emergency stop torque ^{a) b) e)} (permitted 1000 times during the service life of the gearbox)	T_{2Not}	Nm	1000	1000	1000	1000	1000	1000	1000	1000		
		in.lb	8851	8851	8851	8851	8851	8851	8851	8851		
Permitted average input speed ^{d)} (at T_{2a} and 20 °C ambient temperature)	n_{1N}	rpm	1600	1800	1900	2600	2500	3000	2900	3000		
Max. input speed	n_{1Max}	rpm	4000	4000	4000	6000	6000	6000	6000	6000		
Mean no load running torque ^{b)} (at $n_1=3000$ rpm and 20 °C gearbox temperature)	T_{012}	Nm	4.6	3.1	2.6	1.6	1.5	1.2	1.1	0.97		
		in.lb	41	27	23	14	13	11	9.7	8.6		
Max. backlash	j_l	arcmin	≤ 8			≤ 10						
Torsional rigidity ^{b)}	C_{i21}	Nm/arcmin	55	44	44	55	44	55	44	44		
		in.lb/arcmin	487	389	389	487	389	487	389	389		
Max. axial force ^{c)}	F_{2AMax}	N	9870			9870						
		lb _f	2221			2221						
Max. lateral force ^{c)}	F_{2QMax}	N	9900			9900						
		lb _f	2228			2228						
Max. tilting moment	M_{2KMMax}	Nm	952			952						
		in.lb	8426			8426						
Efficiency at full load	η	%	97			95						
Service life	L_n	h	> 20000			> 20000						
Weight (incl. standard adapter plate)	m	kg	19			20						
		lb _m	42			44						
Operating noise (at reference ratio and reference speed – ratio-specific values available in cymex [®])	L_{PA}	dB(A)	≤ 68			≤ 65						
Max. permitted housing temperature		°C	+90			+90						
		°F	+194			+194						
Ambient temperature		°C	-15 to +40			-15 to +40						
		°F	+5 to +104			+5 to +104						
Lubrication			Lubricated for life									
Direction of rotation			In- and output same direction									
Protection class			IP 65									
Elastomer coupling (recommended product type – validate sizing with cymex [®])			ELC-0300BA040.000-X									
Bore diameter of coupling on the application side		mm	X = 020.000 - 045.000									
Mass moment of inertia (relates to the drive) Clamping hub diameter [mm]	E	19	J_1	kgcm ²	-	-	-	1.2	1.1	1	0.88	0.82
				10 ⁻³ in.lb.s ²	-	-	-	1.1	0.97	0.89	0.78	0.73
	G	24	J_1	kgcm ²	-	-	-	2	1.9	1.8	1.7	1.6
				10 ⁻³ in.lb.s ²	-	-	-	1.8	1.7	1.6	1.5	1.4
	H	28	J_1	kgcm ²	-	-	-	1.7	1.6	1.5	1.4	1.3
				10 ⁻³ in.lb.s ²	-	-	-	1.5	1.4	1.3	1.2	1.2
	I	32	J_1	kgcm ²	-	-	-	5.8	5.7	5.6	5.4	5.4
				10 ⁻³ in.lb.s ²	-	-	-	5.1	5	5	4.8	4.8
	K	38	J_1	kgcm ²	8.7	7.3	7.2	7	6.9	6.8	6.6	6.5
				10 ⁻³ in.lb.s ²	7.7	6.5	6.4	6.2	6.1	6	5.8	5.8

Please use our sizing software cymex[®] for a detailed sizing – www.wittenstein-cymex.com

^{a)} Valid for torque transmission only

^{b)} Valid for standard clamping hub diameter

^{c)} Refers to center of the output shaft or flange

^{d)} Please reduce input speed at higher ambient temperatures

^{e)} Valid for: Smooth shaft

1-stage

up to 38⁴⁾ (K)⁵⁾
clamping hub
diameter

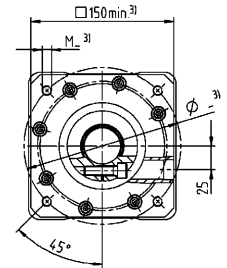
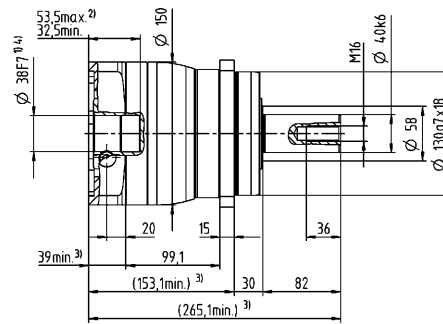
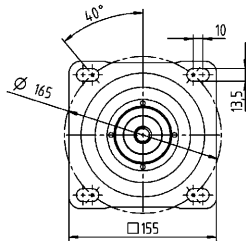

2-stage

up to 28⁴⁾ (H)⁵⁾
clamping hub
diameter

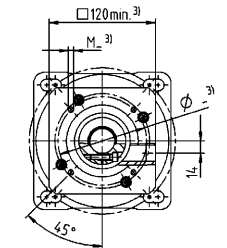
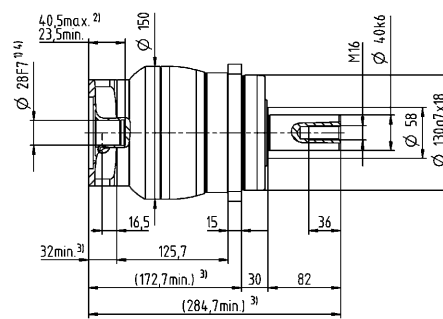
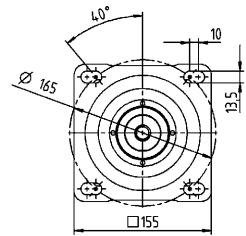

Motor shaft diameter [mm]

up to 38⁴⁾ (K)
clamping hub
diameter

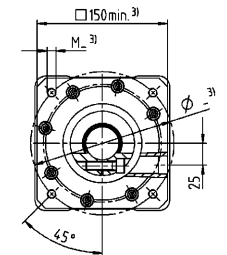
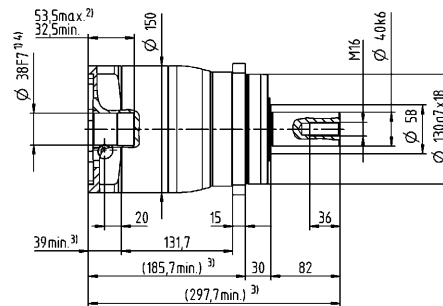
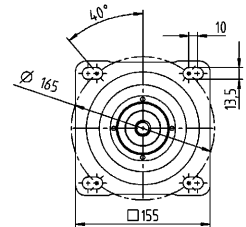

Planetary Gearboxes
Value Line

Other output variants

Shaft with key

Splined shaft (DIN 5480)

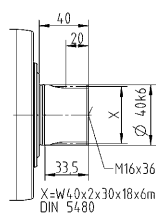
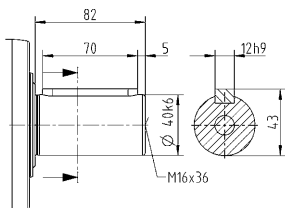

Non-tolerated dimensions are nominal dimensions

¹⁾ Check motor shaft fit

²⁾ Min. / Max. permissible motor shaft length

Longer motor shafts are possible, please contact alpha

³⁾ The dimensions depend on the motor

⁴⁾ Smaller motor shaft diameter is compensated

by a bushing with a minimum thickness of 1 mm

⁵⁾ Standard clamping hub diameter

NPR 015 MA 1-/2-stage

			1-stage		2-stage							
Ratio	i		3	4	12	15	16	20	28	30	40	
Max. torque ^{a) b) e)}	T_{2a}	Nm	80	67	62	67	67	67	67	62	67	
		in.lb	708	593	549	593	593	593	593	593	549	593
Max. acceleration torque ^{e)} (max. 1000 cycles per hour)	T_{2B}	Nm	55	42	39	42	42	42	42	42	39	42
		in.lb	487	372	345	372	372	372	372	372	345	372
Emergency stop torque ^{a) b) e)} (permitted 1000 times during the service life of the gearbox)	T_{2Not}	Nm	80	80	80	80	80	80	80	80	80	80
		in.lb	708	708	708	708	708	708	708	708	708	708
Permitted average input speed ^{d)} (at T_{2N} and 20 °C ambient temperature)	n_{1N}	rpm	2600	2800	3800	4000	3800	4000	4300	4600	4600	
Max. input speed	n_{1Max}	rpm	8000	8000	10000	10000	10000	10000	10000	10000	10000	
Mean no load running torque ^{b)} (at $n_1=3000$ rpm and 20 °C gearbox temperature)	T_{012}	Nm	0.98	0.78	0.34	0.29	0.29	0.25	0.21	0.21	0.19	
		in.lb	8.7	6.9	3	2.6	2.6	2.2	1.9	1.9	1.7	
Max. backlash	j_l	arcmin	≤ 8		≤ 10							
Torsional rigidity ^{b)}	C_{121}	Nm/arcmin	4	4	4	4	4	4	4	4	4	
		in.lb/arcmin	35	35	35	35	35	35	35	35	35	
Max. axial force ^{c)}	F_{2AMax}	N	2400		2400							
		lb _f	540		540							
Max. lateral force ^{c)}	F_{2QMMax}	N	2800		2800							
		lb _f	630		630							
Max. tilting moment	M_{2KMMax}	Nm	152		152							
		in.lb	1345		1345							
Efficiency at full load	η	%	97		95							
Service life	L_n	h	> 20000		> 20000							
Weight (incl. standard adapter plate)	m	kg	1.9		2							
		lb _m	4.2		4.4							
Operating noise (at reference ratio and reference speed – ratio-specific values available in cymex®)	L_{PA}	dB(A)	≤ 59		≤ 58							
Max. permitted housing temperature		°C	+90		+90							
		°F	+194		+194							
Ambient temperature		°C	-15 to +40		-15 to +40							
		°F	+5 to +104		+5 to +104							
Lubrication			Lubricated for life									
Direction of rotation			In- and output same direction									
Protection class			IP 65									
Elastomer coupling (recommended product type – validate sizing with cymex®)			ELC-0060BA016.000-X									
Bore diameter of coupling on the application side		mm	X = 012.000 - 032.000									
Mass moment of inertia (relates to the drive) Clamping hub diameter [mm]	Z	8	J_1	kgcm ²	-	-	0.04	0.04	0.03	0.03	0.03	0.03
				10 ⁻³ in.lb.s ²	-	-	0.04	0.04	0.03	0.03	0.03	0.03
	A	9	J_1	kgcm ²	0.25	0.19	0.04	0.04	0.03	0.03	0.03	0.03
				10 ⁻³ in.lb.s ²	0.22	0.17	0.04	0.04	0.03	0.03	0.03	0.03
	B	11	J_1	kgcm ²	0.26	0.21	0.06	0.06	0.05	0.05	0.05	0.05
				10 ⁻³ in.lb.s ²	0.23	0.19	0.05	0.05	0.04	0.04	0.04	0.04
	C	14	J_1	kgcm ²	0.34	0.28	0.14	0.14	0.14	0.13	0.13	0.14
				10 ⁻³ in.lb.s ²	0.3	0.25	0.12	0.12	0.12	0.12	0.12	0.12
	D	16	J_1	kgcm ²	0.47	0.41	-	-	-	-	-	-
				10 ⁻³ in.lb.s ²	0.42	0.36	-	-	-	-	-	-
	E	19	J_1	kgcm ²	0.55	0.49	-	-	-	-	-	-
				10 ⁻³ in.lb.s ²	0.49	0.43	-	-	-	-	-	-

Please use our sizing software cymex® for a detailed sizing – www.wittenstein-cymex.com

^{a)} Valid for torque transmission only

^{b)} Valid for standard clamping hub diameter

^{c)} Refers to center of the output shaft or flange

^{d)} Please reduce input speed at higher ambient temperatures

^{e)} Valid for: Smooth shaft

1-stage

up to 14⁴⁾ (C)⁵⁾
clamping hub diameter

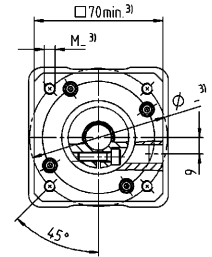
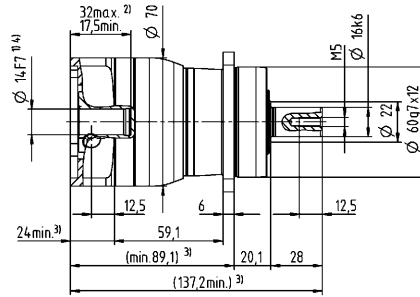
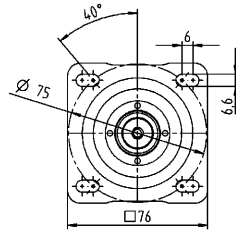

up to 19⁴⁾ (E)
clamping hub diameter

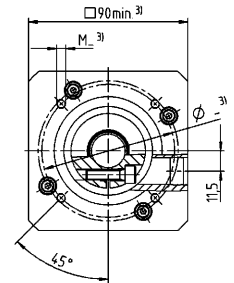
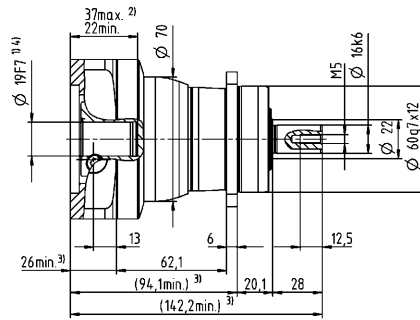
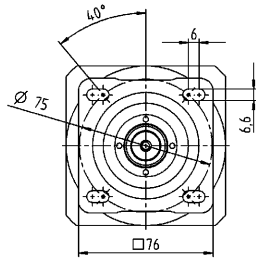

2-stage

up to 11⁴⁾ (B)⁵⁾
clamping hub diameter

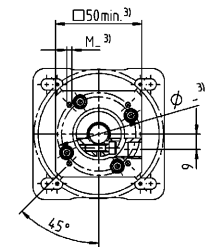
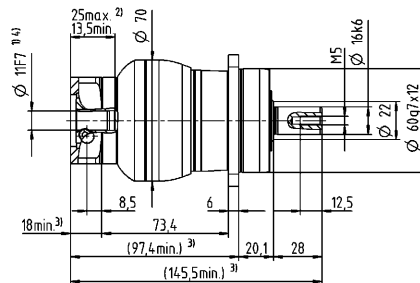
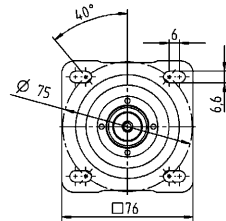

up to 14⁴⁾ (C)
clamping hub diameter

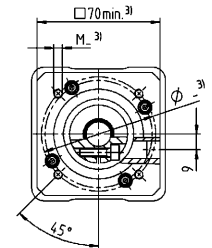
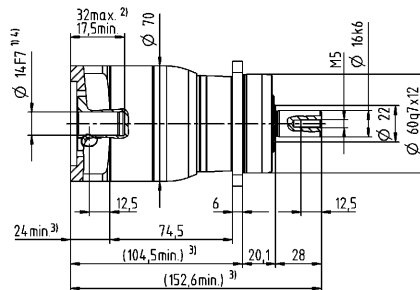
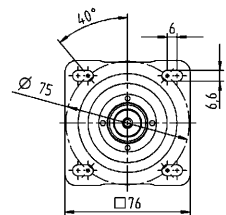

Motor shaft diameter [mm]

Other output variants

Shaft with key

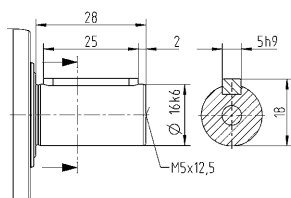

Splined shaft (DIN 5480)

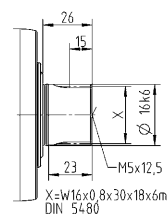

Non-tolerated dimensions are nominal dimensions

¹⁾ Check motor shaft fit

²⁾ Min. / Max. permissible motor shaft length

Longer motor shafts are possible, please contact alpha

³⁾ The dimensions depend on the motor

⁴⁾ Smaller motor shaft diameter is compensated

by a bushing with a minimum thickness of 1 mm

⁵⁾ Standard clamping hub diameter

NPR 025 MA 1-/2-stage

			1-stage		2-stage								
Ratio	i		3	4	9	12	15	16	20	28	30	40	
Max. torque ^{a) b) e)}	T_{2a}	Nm	185	185	185	185	185	185	185	185	168	185	
		in.lb	1637	1637	1637	1637	1637	1637	1637	1637	1637	1487	1637
Max. acceleration torque ^{e)} (max. 1000 cycles per hour)	T_{2B}	Nm	125	115	125	125	120	115	115	115	105	115	
		in.lb	1106	1018	1106	1106	1062	1018	1018	1018	929	1018	
Emergency stop torque ^{a) b) e)} (permitted 1000 times during the service life of the gearbox)	T_{2Not}	Nm	190	190	190	190	190	190	190	190	190	190	
		in.lb	1682	1682	1682	1682	1682	1682	1682	1682	1682	1682	
Permitted average input speed ^{d)} (at T_{2N} and 20 °C ambient temperature)	n_{1N}	rpm	2400	2600	2800	3500	3700	3500	3700	4000	4300	4300	
Max. input speed	n_{1Max}	rpm	7000	7000	8000	8000	8000	8000	8000	8000	8000	8000	
Mean no load running torque ^{b)} (at $n_1=3000$ rpm and 20 °C gearbox temperature)	T_{012}	Nm	1.8	1.5	0.67	0.55	0.47	0.46	0.4	0.34	0.33	0.29	
		in.lb	16	13	5.9	4.9	4.2	4.1	3.5	3	2.9	2.6	
Max. backlash	j_l	arcmin	≤ 8		≤ 10								
Torsional rigidity ^{b)}	C_{i21}	Nm/arcmin	12	12	12	12	12	12	12	12	12	12	
		in.lb/arcmin	106	106	106	106	106	106	106	106	106	106	
Max. axial force ^{c)}	F_{2AMax}	N	3350		3350								
		lb _f	754		754								
Max. lateral force ^{c)}	F_{2QMMax}	N	4200		4200								
		lb _f	945		945								
Max. tilting moment	M_{2KMMax}	Nm	236		236								
		in.lb	2089		2089								
Efficiency at full load	η	%	97		95								
Service life	L_n	h	> 20000		> 20000								
Weight (incl. standard adapter plate)	m	kg	3.7		4								
		lb _m	8.2		8.8								
Operating noise (at reference ratio and reference speed – ratio-specific values available in cymex®)	L_{PA}	dB(A)	≤ 61		≤ 59								
		°C	+90		+90								
Max. permitted housing temperature		°F	+194		+194								
		°C	-15 to +40		-15 to +40								
Ambient temperature		°F	+5 to +104		+5 to +104								
			Lubricated for life										
Direction of rotation			In- and output same direction										
Protection class			IP 65										
Elastomer coupling (recommended product type – validate sizing with cymex®)			ELC-0060BA022.000-X										
Bore diameter of coupling on the application side		mm	X = 012.000 - 032.000										
Mass moment of inertia (relates to the drive) Clamping hub diameter [mm]	A	9	J_1	kgcm ²	-	-	0.26	0.22	0.21	0.21	0.2	0.19	0.19
				10 ⁻³ in.lb.s ²	-	-	0.23	0.19	0.19	0.19	0.18	0.17	0.17
	B	11	J_1	kgcm ²	-	-	0.28	0.24	0.23	0.23	0.22	0.21	0.21
				10 ⁻³ in.lb.s ²	-	-	0.25	0.21	0.2	0.2	0.19	0.19	0.19
	C	14	J_1	kgcm ²	0.58	0.47	0.35	0.31	0.3	0.3	0.3	0.29	0.28
				10 ⁻³ in.lb.s ²	0.51	0.42	0.31	0.27	0.27	0.27	0.27	0.26	0.25
	D	16	J_1	kgcm ²	0.73	0.62	0.48	0.44	0.43	0.43	0.42	0.41	0.41
				10 ⁻³ in.lb.s ²	0.65	0.55	0.42	0.39	0.38	0.38	0.37	0.36	0.36
	E	19	J_1	kgcm ²	0.81	0.71	0.56	0.52	0.51	0.52	0.51	0.5	0.5
				10 ⁻³ in.lb.s ²	0.72	0.63	0.5	0.46	0.45	0.46	0.45	0.44	0.44
	G	24	J_1	kgcm ²	1.8	1.7	-	-	-	-	-	-	-
				10 ⁻³ in.lb.s ²	1.6	1.5	-	-	-	-	-	-	-
	H	28	J_1	kgcm ²	1.6	1.4	-	-	-	-	-	-	-
				10 ⁻³ in.lb.s ²	1.4	1.2	-	-	-	-	-	-	-

Please use our sizing software cymex® for a detailed sizing – www.wittenstein-cymex.com

^{a)} Valid for torque transmission only

^{b)} Valid for standard clamping hub diameter

^{c)} Refers to center of the output shaft or flange

^{d)} Please reduce input speed at higher ambient temperatures

^{e)} Valid for: Smooth shaft

1-stage

up to 19⁴⁾ (E)⁵⁾
clamping hub diameter

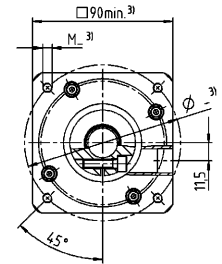
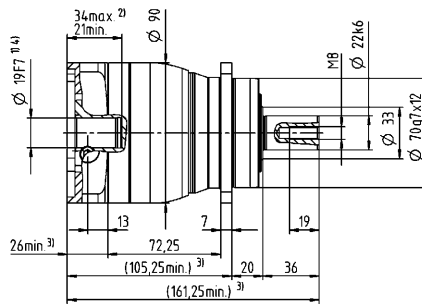
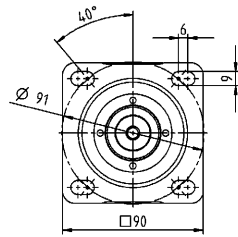

up to 28⁴⁾ (H)
clamping hub diameter

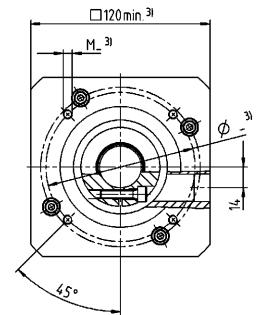
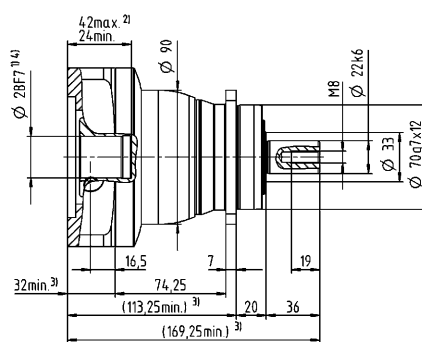
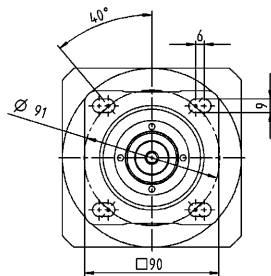

2-stage

up to 14⁴⁾ (C)⁵⁾
clamping hub diameter

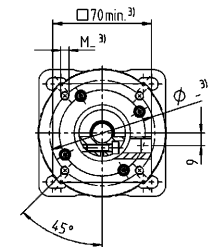
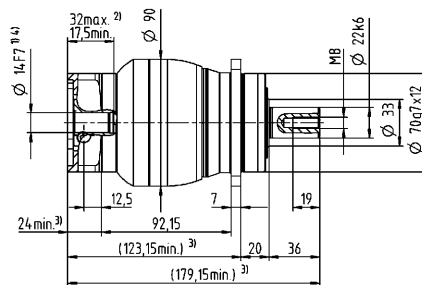
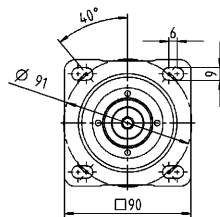

up to 19⁴⁾ (E)
clamping hub diameter

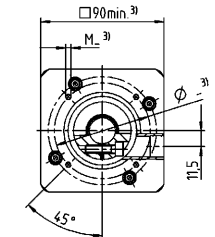
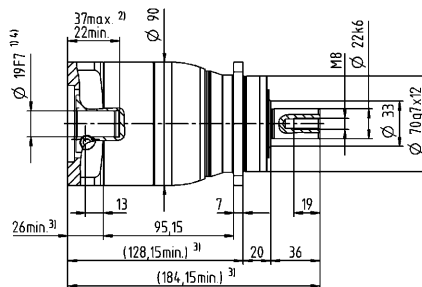
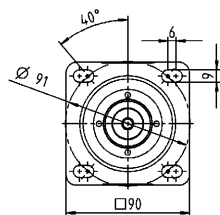

Motor shaft diameter [mm]

Other output variants

Shaft with key

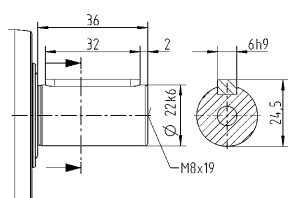

Splined shaft (DIN 5480)

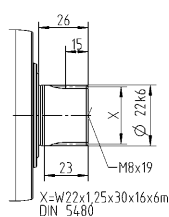

Non-tolerated dimensions are nominal dimensions

¹⁾ Check motor shaft fit

²⁾ Min. / Max. permissible motor shaft length

Longer motor shafts are possible, please contact alpha

³⁾ The dimensions depend on the motor

⁴⁾ Smaller motor shaft diameter is compensated

by a bushing with a minimum thickness of 1 mm

⁵⁾ Standard clamping hub diameter

NPR 035 MA 1-/2-stage

			1-stage		2-stage									
Ratio	i		3	4	9	12	15	16	20	28	30	40		
Max. torque ^{a) b) e)}	T_{2a}	Nm	480	480	480	480	480	480	480	480	432	480		
		in.lb	4248	4248	4248	4248	4248	4248	4248	4248	4248	3824	4248	
Max. acceleration torque ^{e)} (max. 1000 cycles per hour)	T_{2B}	Nm	305	305	305	305	300	305	305	305	270	305		
		in.lb	2699	2699	2699	2699	2655	2699	2699	2699	2390	2699		
Emergency stop torque ^{a) b) e)} (permitted 1000 times during the service life of the gearbox)	T_{2Not}	Nm	500	500	500	500	500	500	500	500	500	500		
		in.lb	4425	4425	4425	4425	4425	4425	4425	4425	4425	4425		
Permitted average input speed ^{d)} (at T_{2N} and 20 °C ambient temperature)	n_{1N}	rpm	1800	2000	2600	3300	3400	3300	3400	3600	3900	3900		
Max. input speed	n_{1Max}	rpm	6000	6000	7000	7000	7000	7000	7000	7000	7000	7000		
Mean no load running torque ^{b)} (at $n_1=3000$ rpm and 20 °C gearbox temperature)	T_{012}	Nm	3.5	2.8	1.7	1.4	1.2	1.2	1.1	0.93	0.88	0.81		
		in.lb	31	25	15	12	11	11	9.7	8.2	7.8	7.2		
Max. backlash	j_l	arcmin	≤ 8		≤ 10									
Torsional rigidity ^{b)}	C_{i21}	Nm/arcmin	30	30	30	30	30	30	30	30	30	30		
		in.lb/arcmin	266	266	266	266	266	266	266	266	266	266		
Max. axial force ^{c)}	F_{2AMax}	N	5650		5650									
		lb _f	1271		1271									
Max. lateral force ^{c)}	F_{2QMMax}	N	6600		6600									
		lb _f	1485		1485									
Max. tilting moment	M_{2KMMax}	Nm	487		487									
		in.lb	4310		4310									
Efficiency at full load	η	%	97		95									
Service life	L_n	h	> 20000		> 20000									
Weight (incl. standard adapter plate)	m	kg	8.6		9									
		lb _m	19		20									
Operating noise (at reference ratio and reference speed – ratio-specific values available in cymex®)	L_{PA}	dB(A)	≤ 65		≤ 61									
		°C	+90		+90									
Max. permitted housing temperature		°F	+194		+194									
		°C	-15 to +40		-15 to +40									
Ambient temperature		°F	+5 to +104		+5 to +104									
			Lubricated for life											
Direction of rotation			In- and output same direction											
Protection class			IP 65											
Elastomer coupling (recommended product type – validate sizing with cymex®)			ELC-0150BA032.000-X											
Bore diameter of coupling on the application side		mm	X = 019.000 - 036.000											
Mass moment of inertia (relates to the drive) Clamping hub diameter [mm]	C	14	J_1	kgcm ²	-	-	0.6	0.59	0.6	0.43	0.42	0.37	0.52	0.36
				10 ⁻³ in.lb.s ²	-	-	0.53	0.52	0.53	0.38	0.37	0.33	0.46	0.32
	D	16	J_1	kgcm ²	-	-	0.75	0.74	0.74	0.58	0.57	0.5	0.67	0.51
				10 ⁻³ in.lb.s ²	-	-	0.66	0.65	0.65	0.51	0.5	0.44	0.59	0.45
	E	19	J_1	kgcm ²	2.5	1.7	0.84	0.83	0.83	0.66	0.65	0.6	0.75	0.6
				10 ⁻³ in.lb.s ²	2.2	1.5	0.74	0.73	0.73	0.58	0.58	0.53	0.66	0.53
	G	24	J_1	kgcm ²	3.3	2.4	1.9	1.9	1.9	1.7	1.7	1.6	1.8	1.6
				10 ⁻³ in.lb.s ²	2.9	2.1	1.7	1.6	1.7	1.5	1.5	1.5	1.6	1.4
	H	28	J_1	kgcm ²	3	2.2	1.6	1.6	1.6	1.4	1.4	1.3	1.5	1.3
				10 ⁻³ in.lb.s ²	2.7	1.9	1.4	1.4	1.4	1.2	1.2	1.2	1.3	1.2
	I	32	J_1	kgcm ²	7.1	6.2	-	-	-	-	-	-	-	-
				10 ⁻³ in.lb.s ²	6.3	5.5	-	-	-	-	-	-	-	-
K	38	J_1	kgcm ²	8.3	7.4	-	-	-	-	-	-	-	-	
			10 ⁻³ in.lb.s ²	7.3	6.5	-	-	-	-	-	-	-	-	

Please use our sizing software cymex® for a detailed sizing – www.wittenstein-cymex.com

^{a)} Valid for torque transmission only

^{b)} Valid for standard clamping hub diameter

^{c)} Refers to center of the output shaft or flange

^{d)} Please reduce input speed at higher ambient temperatures

^{e)} Valid for: Smooth shaft

1-stage

up to 24/28⁴⁾
(G⁵⁾/H)
clamping hub
diameter

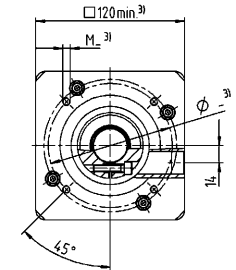
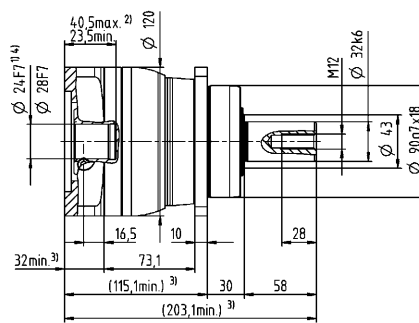
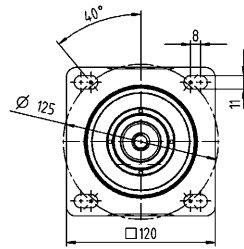

up to 38⁴⁾ (K)
clamping hub
diameter

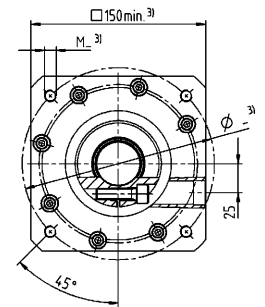
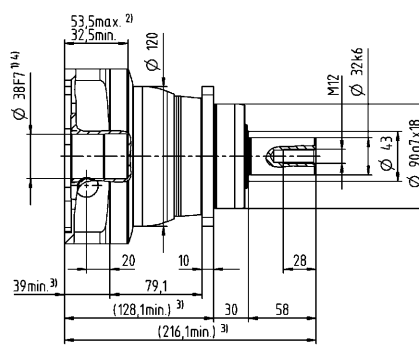
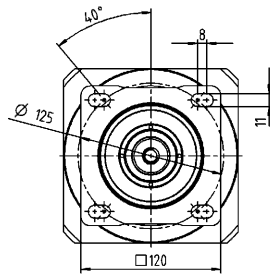

2-stage

up to 19⁴⁾ (E)⁵⁾
clamping hub
diameter

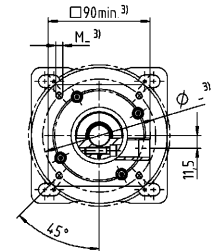
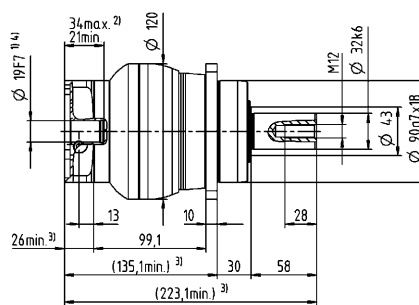
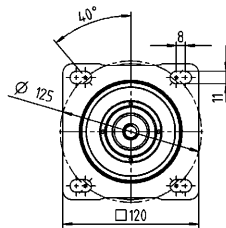

up to 28⁴⁾ (H)
clamping hub
diameter

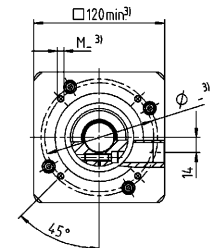
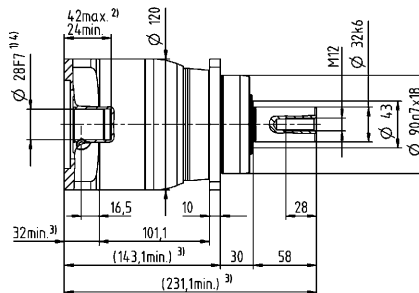
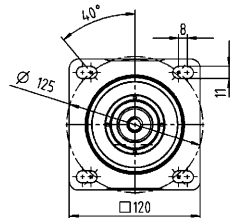

Motor shaft diameter [mm]

Other output variants

Shaft with key

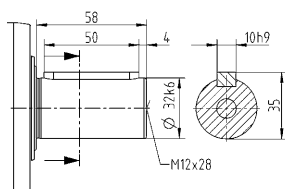

Splined shaft (DIN 5480)

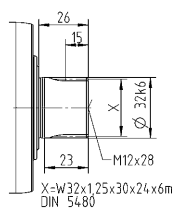

Non-tolerated dimensions are nominal dimensions

¹⁾ Check motor shaft fit

²⁾ Min. / Max. permissible motor shaft length

Longer motor shafts are possible, please contact alpha

³⁾ The dimensions depend on the motor

⁴⁾ Smaller motor shaft diameter is compensated

by a bushing with a minimum thickness of 1 mm

⁵⁾ Standard clamping hub diameter