

## 2 Product Description

### 2.1 General information

#### Ambient temperature

Gear units and gearmotors from SEW-EURODRIVE can be operated in a wide ambient temperature range. The following standard temperature ranges are permitted for filling the gear units according to the lubricant table:

Gear unit	Filled with	Permitted standard temperature range
R, F, and K	CLP(CC) VG220	-15°C ... +40°C
S	CLP(CC) VG680	0°C ... +40°C
W	CLP(SEW-PG) VG460	-20°C ... +40°C

The rated data of the gear units and gearmotors specified in SEW-EURODRIVE catalogs refer to an ambient temperature of +25°C (77°F).

With proper project planning, gear units and gearmotors from SEW-EURODRIVE can operate from -40°C to +60°C (-40°F to +140°F). Project planning must consider special operating conditions and use appropriate lubricants and seals. It is especially important for the following gear units:

- R, K, F gear units > size 87 with small ratios
- All S gear units (helical-worm) with small ratios

SEW-EURODRIVE will gladly perform this project planning for you. Or, you may visit [www.ptpilot.com](http://www.ptpilot.com) for complete specifications and quotations. PT Pilot® automatically calculates your oil sump temperature based upon your mounting position and ambient temperature. Where applicable, PT Pilot® adds synthetic oil and FKM seals for proper protection against heat.

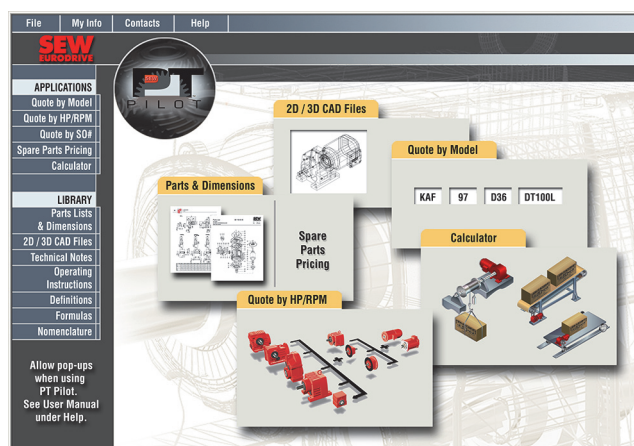

If the drive is to be operated by a frequency inverter, you must also consider the thermal effects of inverter operation during your project planning.

- Altitude** Due to the low air density at high altitudes, heat dissipation on the surface of motors and gear units decreases. The rated data listed in the catalog applies to an installation altitude of maximum 3280 feet above sea level. Project planning must consider Installation altitudes of more than 3280 feet to ensure proper cooling.
- Power and torque** The power and torque ratings listed in the catalogs refer to mounting position M1 and similar mounting positions in which the input stage is not completely submerged in oil. In addition, the gear units are assumed to be standard versions with standard lubrication and normal ambient conditions.
- Noise** The noise levels of all SEW-EURODRIVE gear units, motors and gearmotors are well within the maximum permitted noise levels set forth in the VDI guideline 2159 for gear units and IEC/EN 60034 for motors.
- Paint** Gear units from SEW-EURODRIVE are painted with "RAL 5001 blue" as standard. Alternate paints include RAL 7031 blue/gray, metallic gray, black, and white. Special paints are available upon request.
- Ambient air flow** Gear units and gearmotors must be mounted on the driven machine in such a way that both axially and radially there is enough space left for unimpeded air flow.
- Compound gear units** Particularly low output speeds are possible by using a compound (multi-stage) gear unit. These units contain an additional helical gear unit (RF style) on the input in order to achieve much higher ratios than those in a single gear unit.  
It may be necessary to limit the motor power or to provide torque overload protection to ensure that the maximum permissible output torque of the gear unit is not exceeded.
- Reduced backlash** Helical (R-series), the Snuggler® helical (F-series) and helical-bevel (K-series) gear units with reduced backlash are available in gear unit sizes 37 and larger. The circumferential backlash of these gear units is considerably less than that of the standard version; therefore, positioning tasks can be performed with great precision. The circumferential backlash is specified in angular minutes [ ' ] in the technical data. The circumferential backlash for the output shaft is specified without load (max. 1% of the rated output torque) with the gear unit input end blocked. For further information, refer to chapter "Reduced backlash gear units" on page 125.
- RM gear units** RM gear units are a special type of helical gear unit with an extended output bearing hub. They are designed especially for agitation applications and allow for high overhung loads, axial loads, and bending moments. Excluding overhung load ratings, all other ratings are the same as for standard helical gear units. See special project planning notes for RM gearmotors in the "Project Planning/RM gear units" chapter on page 64.

### **SPIROPLAN® gear units**

SPIROPLAN® right-angle gear units (W-series) are robust right-angle gear units with either single or two stage gearing. Unlike the helical-worm gear units (S-series) that use both bronze and metal gears with sliding friction, the SPIROPLAN® units use only steel gears with a special meshing pattern that incorporates both sliding and rolling friction for greater efficiency.

The shorter design along with the aluminum housing of the SPIROPLAN® produce a very compact and lightweight drive solution.

The wear-free gearing and the life-long lubrication allow for long periods of maintenance-free operation. For maximum versatility, the hole spacing on the feet is the same on all three sides. In addition, the shaft height remains the same regardless of which side the unit is mounted.

Two different flange diameters are available. And upon request, SPIROPLAN® gearmotors can be equipped with a torque arm.

### **K..19 - K..49 hypoid gear units**

The latest edition to the SEW-EURODRIVE family of gearmotors is the K..19 - K..49 units. These right-angle units contain 2-stage hypoid gearing for even greater efficiency than the SPIROPLAN®. Total efficiency ranges from 90% to 96%, depending on the ratio.

### **Weights**

Please note that all weights shown in the catalogs exclude the weight of the oil. The oil weight varies according to gear unit type and gear unit size. The amount of lubricant varies, depending upon the mounting position. Please refer to "Lubricants" in the "Design and Operating Notes" chapter for recommended oil fill quantities. For a more precise weight, refer to the order confirmation.

### **Shaft diameters**

All gear units are available with either metric or inch shafts on the input and the output. In addition, several diameters are available for each gear unit at no extra charge. See the dimension pages beginning on pages 272 (R-series), 407 (F-series), 571 (K-series), 680 (S-series), and 706 (W-series).

## 2.2 Environmental protection

### OS Surface protection

SEW-EURODRIVE offers surface protection for gear units operating under various environmental conditions. Instead of the standard surface protection, motors and gear units are available with surface protection OS2 and OS4 as an option.

Surface Protection	Procedure	Application
OSG	Dip Primer Primer	<b>Primer only</b>
		Additional coating to be applied by customer
Standard	Dip Primer Acrylic Top Coat	<b>Normal ambient conditions</b>
		Indoors for climate controlled buildings with clean atmospheres (ex: shops, airports)
OS2	Dip Primer Acrylic Primer Acrylic Top Coat + UV	<b>Medium environmental impact - with UV protection</b>
		Indoors with high humidity or splashing water (ex: depots, sports halls) Outdoors subject to direct weathering and low pollution (ex: amusement parks, water treatment facilities)
OS4	Dip Primer Epoxy Primer Polyurethane Top Coat Polyurethane Clear Coat	<b>High environmental impact - with UV protection</b>
		Indoor environments with permanent condensation, heavy washdown, severe atmospheric or chemical contamination. Withstands chemical, acidic or caustic agents used for washdown cleaning. Resistant to solvents, grease, sulfur dioxide, and salt. (ex: food processing, breweries, dairies, chemical plants, coastal areas with high salinity)

### Seal and shaft protection

Feature	Design	Application
<b>FKM oil seal</b>	High quality material	Drives subject to chemicals or high temperature
<b>PTFE oil seal</b>	High quality material	Drives subject to chemicals
<b>Stainless steel output shaft</b>	Surface protection through non-corrosive material. All TorqLOC® shafts are available in stainless steel.	Demanding applications where anti-corrosion is mandatory.

### NOCO® fluid

As standard, SEW-EURODRIVE supplies NOCO® fluid with every hollow shaft gear unit to provide corrosion protection. Use NOCO® fluid for lubrication when installing hollow shaft gear units. Care should be taken so that it is not applied to the compression surfaces of a shrink disc or a TorqLOC® clamping collar.

Using this fluid helps to prevent contact corrosion and makes it easier to disassemble the drive at a later time. NOCO® fluid is also suitable for protecting machined metal surfaces that do not have corrosion protection, such as parts of shaft ends or flanges.

NOCO® fluid is a food grade substance according to NSF-H1, as noted by the identification label on its packaging.

### 2.3 Extended storage

You can order gear units prepared for "Extended Storage." SEW-EURODRIVE recommends the "Extended Storage" type for storage periods longer than 9 months.

In this case, a VCI (volatile corrosion inhibitor) is added to the lubricant. Please note that this VCI corrosion inhibitor is only effective in a temperature range between -25°C to +50°C (-13°F to +120°F). In addition, the flange contact surfaces and shaft ends are treated with an anti-corrosion agent.

If not specified otherwise on your order, the gear unit with "extended storage" option will be supplied with OS2 surface protection. You can order OS4 as an option.

INFORMATION	
	<p>Gear units must remain tightly sealed until placed into operation to prevent the VCI corrosion protection agent from evaporating.</p> <p>Gear units will be supplied with oil to the appropriate level depending on the specified mounting position (M1 to M6). Always check the oil level before you start operating the gear unit for the first time.</p>

#### Storage conditions

Observe the storage conditions specified in the following table for extended storage:

Climate zone	Packaging <sup>1)</sup>	Storage location <sup>2)</sup>	Storage duration
Temperate  (Europe, USA, Canada, China and Russia, excluding tropical zones)	Packed in containers and sealed in a plastic wrap that contains desiccant and a moisture indicator.	With roof, protected against rain and snow. No shock loads.	Up to three years with regular checks of the packaging and moisture indicator (humidity < 50%).
	Open	With roof, enclosed at constant temperature and humidity (40°F < T < 140°F, 50% relative humidity). No sudden temperature fluctuations. Controlled ventilation with filter (free from dust and dirt). Protected against aggressive vapors and shocks.	Two years or more with regular inspections.  Check for cleanliness and mechanical damage during inspection.  Check corrosion protection.
Tropical  (Asia, Africa, Central and South America, Australia, New Zealand excluding temperate zones)	Packed in containers and sealed in a plastic wrap that contains desiccant and a moisture indicator.	With roof, protected against rain and shocks.	Up to three years with regular checks of the packaging and moisture indicator (humidity < 50%).
	Protected against insect damage and mildew by chemical treatment.	With roof, enclosed at constant temperature and humidity (40°F < T < 140°F, 50% relative humidity). No sudden temperature fluctuations. Controlled ventilation with filter (free from dust and dirt). Protected against aggressive vapors and shocks. Protected against insect damage.	Two years or more with regular inspections.  Check for cleanliness and mechanical damage during inspection.  Check corrosion protection.

1) Packaging must be accomplished by an experienced company using the packaging materials that have been explicitly specified for the particular application.

2) SEW-EURODRIVE recommends storing the gear units in the same orientation as the mounting position that is shown on the nameplate.

**2.4 Important ordering information**

	<b>INFORMATION</b>
	The following information is required when ordering a gear unit.

**Direction of rotation of the output shaft**

When ordering a gear unit with an adapter or input shaft that contains a backstop, it is necessary to indicate the direction of rotation of the output shaft. The direction is determined by looking directly at the output shaft. For right-angle gear units with a double output shaft (containing shaft ends at both A and B), the direction must be specified as looking into side A.

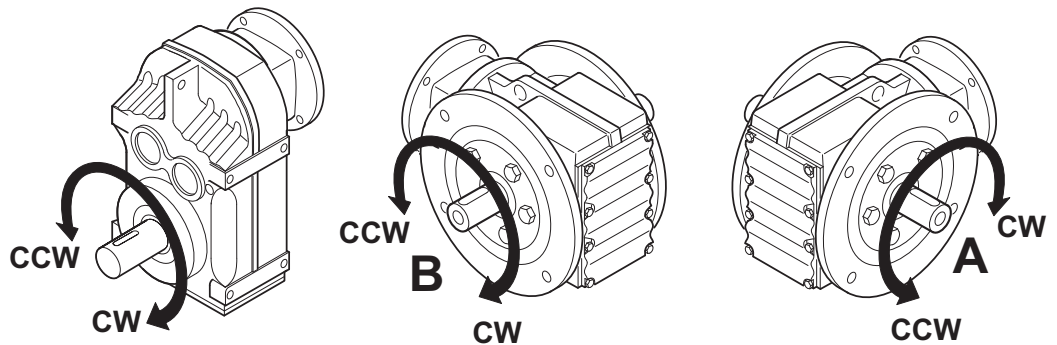

50290AXX

As viewed at the output shaft: CW = Clockwise  
CCW = Counterclockwise

**Position of the output shaft and flange**

For right-angle gear units, the position of the output shaft and the output flange must also be specified:

- A or B
- AB = flange and/or shaft on both sides

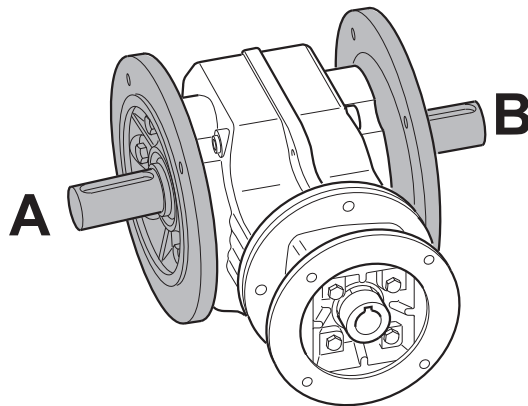

50296AXX

**Position of shaft entry side for right-angle gear units**

For shaft mounted right-angle gear units with either a shrink disc (ex. KH) or TorqLOC® (ex. KT), you must indicate whether A or B is the entry. The entry is the side that the customer's solid shaft first enters during installation. Therefore, it is the side closest to the customer's machine.

2

**NOTE:** on gear units with a TorqLOC® shaft (ex. KT), a symmetrical shaft is available for entry on either A or B. Designation = AB

The shrink disk is always located opposite the entry side. Thus, in the figure below, the entry side is A and the shrink disk side is B.

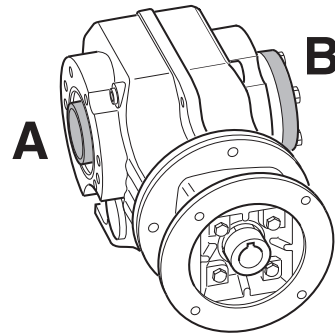

50297AXX

**Position of torque arm for right-angle gear units**

**S-series**

The figure below shows the side and degree options for the torque arm on S-series gear units. The bold degree position is the default location if no other degree is specified.

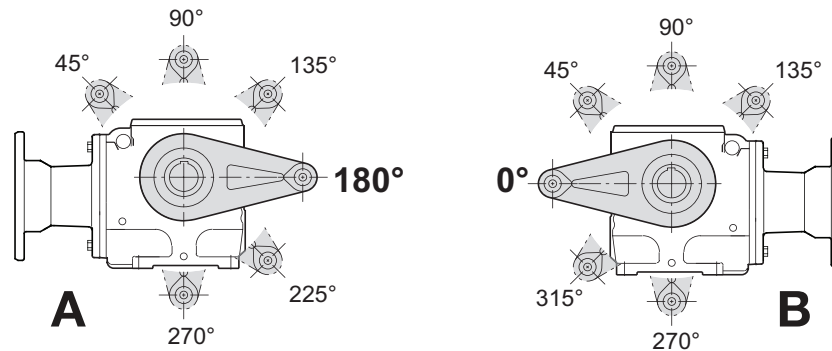

**K-series**

The figure below shows the side locations of the torque arm on K-series when looking into the front end of the gear unit, not when looking into the motor or input.

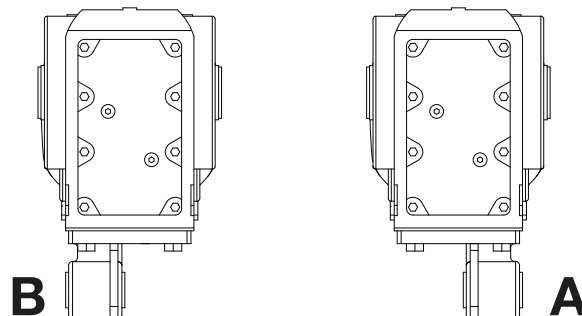

# 2 Product Description

Important ordering information

## Mounting positions

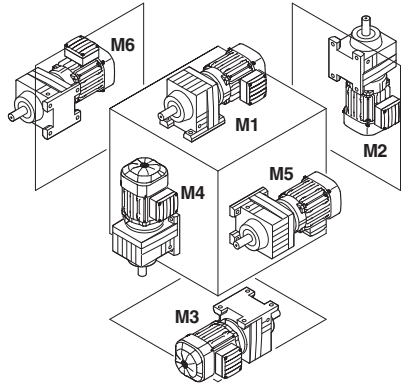

R..

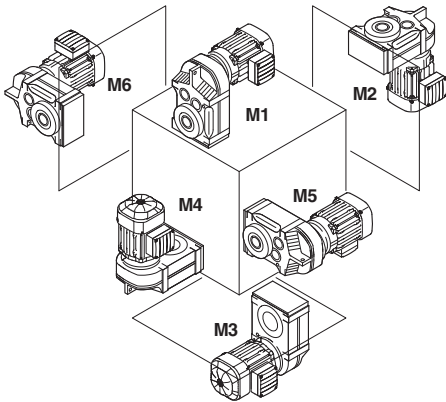
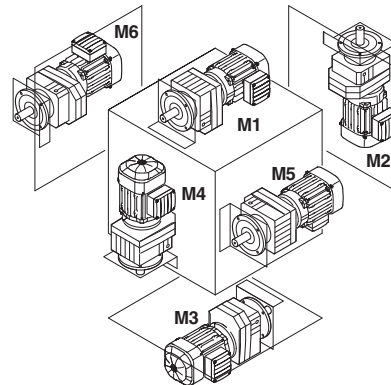

F..

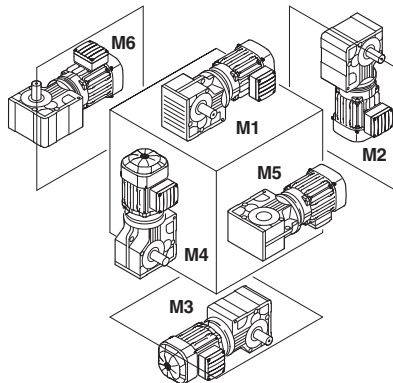
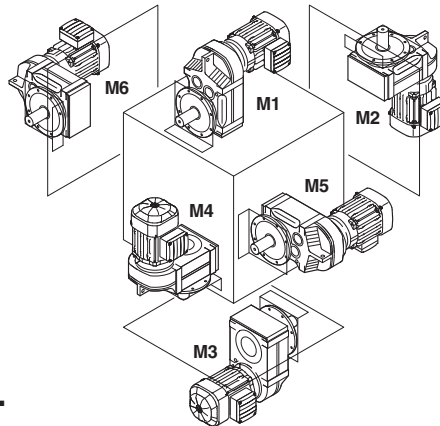

K..  
S..  
W..

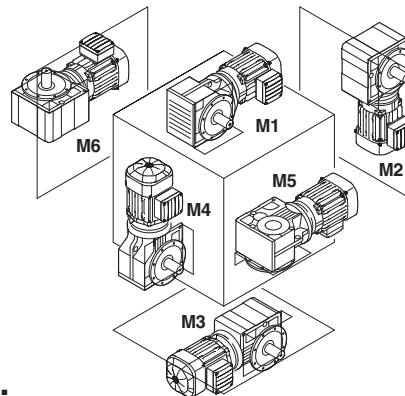

65873axx

## Sample orders

The following examples show the information that is needed for each unit upon ordering.

Type (Examples)	Mounting position	Shaft position	Flange position	Entry Side	Shrink disk position	Direction of rotation on output	Torque Arm Side	Torque Arm Degree
K47../RS	M2	A	-	-	-	CW	-	-
SF77	M6	B	B	-	-	-	-	-
KT97/T	M4	-	-	B	A	-	B	-
KT107	M1	-	-	AB	B	-	-	-
SA67/T	M1	-	-	-	-	-	A	225



## 2.5 Nameplate information

### Example

The following figure shows an example of a nameplate for a helical-worm gear unit with a NEMA C-Face adapter (AM) for a size 145TC motor.

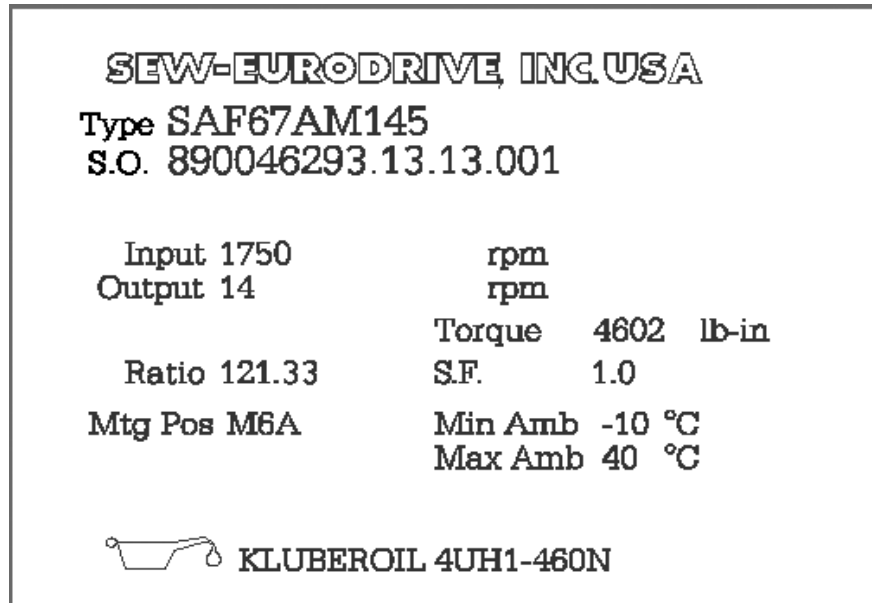

The following information is included on the nameplate:

- Type (Nomenclature)
- SO# (Sales Order / Serial Number)
- Input Speed
- Output Speed
- Ratio
- Mounting Position
- Maximum Output Torque (lb-in)
- Service Factor (S.F.)
- Minimum Ambient Temperature (°C)
- Maximum Ambient Temperature (°C)
- Oil Type

### 2.6 Input components

#### 2.6.1 AD input shaft assembly

The following figure shows a helical gear unit (R-series) with AD input shaft assembly:

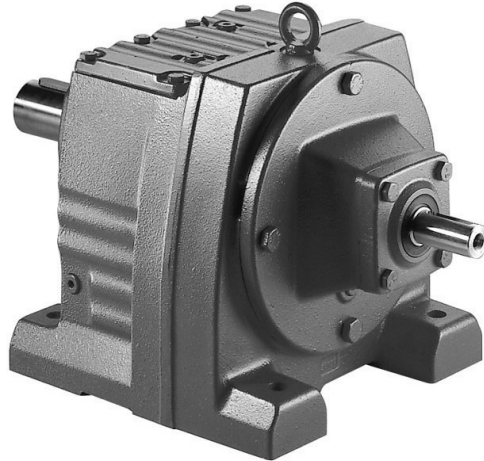

04583AXX

Gear units are available with a solid input shaft assembly. The diameter of the shaft is available in either inch or IEC standard metric. The end of the shaft has a center bore for mounting and attaching drive components.

The bearings on the input shaft are grease-lubricated. NBR oil seals and gap rings are used for sealing the cover. The solid output shaft bearings allows for high overhung loads.

#### **Motor mounting platform AD../P**

Belt drives are available with adjustable motor mounting platform for space-saving installation. The motor mounting platform is arranged parallel to the drive shaft. The standard plate does not contain tapped holes for the motor, but can be ordered with holes, if desired. The distance from the input shaft can be adjusted using threaded columns.

The following figure depicts a helical gear unit (R-series) with input shaft assembly and motor mounting platform AD../P:

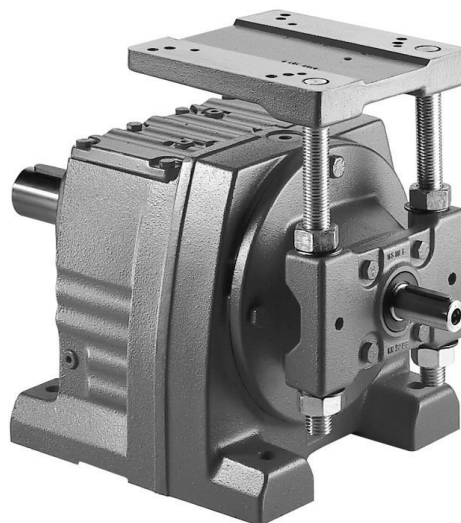

53585AXX

### 2.6.2 AM motor adapter - IEC or NEMA

The following figure shows a helical-worm gear unit (S-series) with AM adapter:

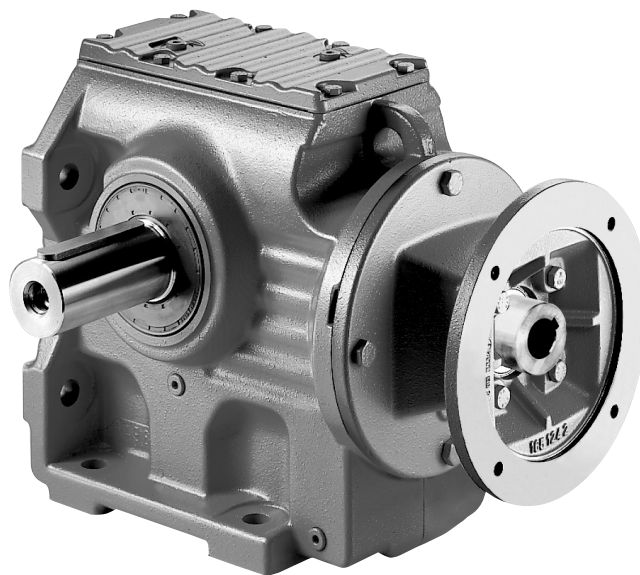

04588AXX

AM adapters are used for mounting motors to SEW gear units according to IEC standard or NEMA (type C or TC) .

Adapters are available for sizes 63 to 280 for IEC motors. Adapters are available for sizes 56 to 365 for NEMA motors. The designation of the adapter size corresponds to the respective IEC or NEMA motor size.

Torque is transmitted between the motor and the gear unit via a fail-safe jaw-type coupling. Vibrations and shock occurring during operation are effectively dampened by a polyurethane "spider" ring gear that fits between the two coupling halves, as shown below.



04589US

#### 2.6.3 AR adapter with torque limiting coupling

The following figure shows a helical-bevel gear unit with AR adapter:



04604AXX

The torque is transmitted non-positive via friction linings. The slip torque of the coupling can be adjusted via a setting nut and cup springs. Different slip torques are possible depending on the thickness and arrangement of the cup springs. In the event of an overload, the coupling slips and interrupts the power flow between motor and gear unit, preventing damages to the system and drive.

A closeup image of the slip coupling is shown below.

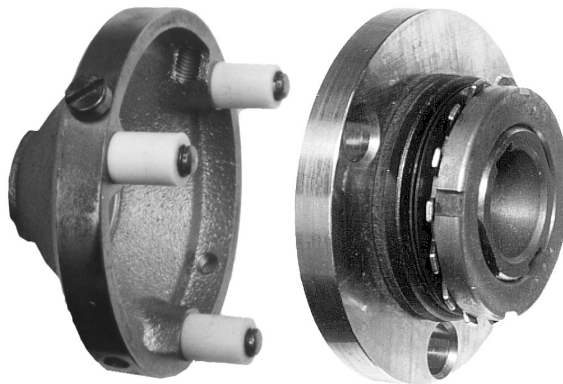

04590US

#### 2.6.4 AT adapter with hydraulic centrifugal coupling

The following figure shows a parallel shaft gear unit (F-series) with AT adapter:

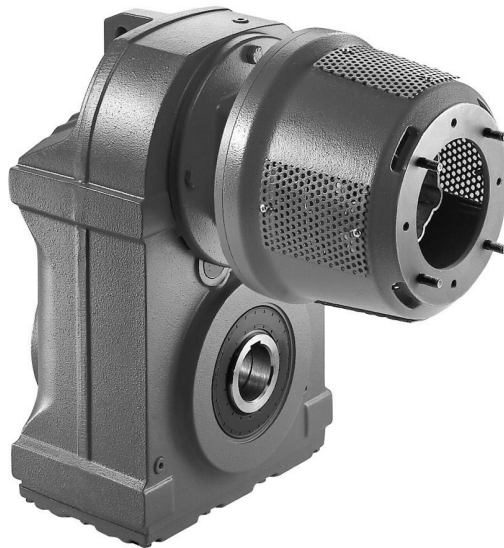

04607AXX

Gear units can be combined with adapters and hydraulic centrifugal couplings for machines with high inertia starting (e.g. mixers, agitators, etc.). The hydraulic centrifugal coupling protects the motor and the driven machine against overload during the startup phase and ensures that the machine starts up smoothly. The coupling is installed in a housing for safety. Cooling of the coupling is ensured by ventilation openings in the housing. The housing accepts SEW motor sizes 71 to 180 (0.50 to 30 HP).

Preferred motor input speeds are 1800 rpm (4-pole) or 3600 rpm (2-pole). Note that the noise level increases when using the 2-pole motor combination.

#### 2.6.5 Swing base with hydraulic centrifugal coupling

SEW-EURODRIVE provides helical-bevel gear units with hydraulic centrifugal coupling (and brake if requested) on a swing base for motors size 200 and larger (40 to 120 HP), as shown below. The relevant dimension sheets are available on request.

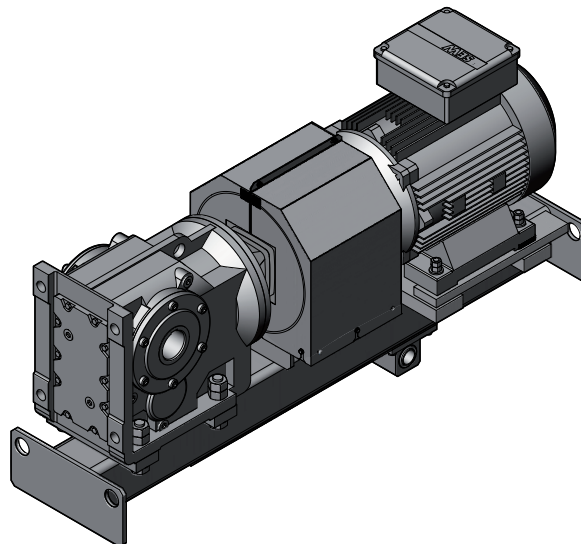

68152AXX

#### 2.6.6 AT..BM(G) adapter with hydraulic centrifugal coupling and disc brake

The following figure shows a parallel shaft gear unit (F-series) with AT adapter and disc brake BM(G):



04611AXX

The adapter with hydraulic centrifugal coupling can be configured with an SEW disc brake if the machine needs to stop in a defined manner. The brake is an electromagnetic disc with a DC coil that is released electrically. Spring force provides the braking. As a result, it satisfies the safety requirement of braking in the event of a power failure. Upon request, the brake can be equipped with manual brake release.

The braking torque can be varied by the number and type of springs used. The brake can be supplied with DC or AC voltage connection. The connection terminals and brake rectifier are located inside a terminal box attached to the adapter.